

**1429 ECK ROAD OUTDOOR STORAGE**  
**MAJOR PLAN 2022-109**  
**ATTACHMENTS**

- 1. Memorandum**
- 2. Site Plan**
- 3. Township Engineer Review dated February 2, 2024**
- 4. Township Water and Sewer Engineer Review dated January 31, 2024**
- 5. Township Water and Sewer Engineer Will Serve Letter dated June 2, 2023**
- 6. Township Geotechnical Consultant Review dated January 31, 2024**
- 7. Lighting Consultant Review dated December 18, 2023**
- 8. Public Works Department Review dated January 3, 2024**
- 9. Community Development Department Review dated February 1, 2024**
- 10. Parks and Recreation Board Review dated November 16, 2023**
- 11. LVPC Review dated June 16, 2023**
- 12. Applicant's Correspondence:**
  - A. Project Narrative dated May 17, 2023**
  - B. Waiver Request Letter dated January 18, 2024**
  - C. Pushkar Frontage Narrative dated January 2, 2024**

**TO: PLANNING COMMISSION**  
**FROM: GREGG R. ADAMS, PLANNER**  
**SUBJECT: 1429 ECK ROAD OUTDOOR STORAGE**  
**MAJOR PLAN 2022-109**  
**REQUEST FOR PRELIMINARY/FINAL PLAN REVIEW**

**DATE: FEBRUARY 2, 2024**

**COPIES: BOARD OF COMMISSIONERS, T. PETRUCCI, D. MANHARDT,**  
**L. HARRIER, L. PERIERA ESQ, A. TALLARIDA, S. PIDCOCK,**  
**APPLICANT, SUB. FILE 2022-109**

**LOCATION AND INTENT:**

An application to develop the property located at 1429 Eck Road. The plan proposes to construct a 79-trailer space parking area (12 of which are to be utilized as 16 reserve standard parking spaces) with 8 standard parking spaces (and 16 afore-mentioned reserved standard parking spaces) and a guard shack on the 5.11-acre parcel. The property is to be served by public water and public sewer and is zoned Industrial Commercial-1 (Special Height Limitation) IC-1. Triple Net Investments CI, LLC is the equitable owner and applicant.

**PREVIOUS TOWNSHIP CONSIDERATION:**

At their October 19, 2023 and January 11, 2024 meetings, the Planning Commission reviewed and took under advisement a preliminary/final plan for 1429 Eck Road Outdoor Storage Major Plan 2022-109.

At their November 28, 2022 hearing, the Zoning Hearing Board granted Special Exception approval with 15 conditions and a variance to allow an unconstructed/striped 16-space parking area to be reserved for 1429 Eck Road Outdoor Storage, as part of Zoning Appeal 2022-09.

The Planning Commission reviewed Sketch Plan submissions for 1429 Eck Road Outdoor Storage Major Plan 2022-109 at their December 15, 2022 and September 15, 2022 meetings.

**REVIEWING AGENCIES COMMENTS:**

- A. Township Engineer** – The comments of the Township Engineer are contained in Mr. Anthony Tallarida’s reviews dated February 2 and January 4, 2024. Mr. Tallarida is not recommending engineering approval at this time. His comments pertain to the supplemental information received on January 18, 2024, waiver requests, plan detail regarding the adjoining Pushkar tract, stormwater management, traffic, and outside agency approvals.
- B. Township Water & Sewer Engineer** –Comments from the Township Water & Sewer Engineer are contained in Mr. Jason Newhard’s review dated January 31, 2024. His comments pertain to plan detail.
- C. Township Geotechnical Consultant** – Comments from the Township Geotechnical Consultant are contained in Mr. Chris Taylor’s review dated January 31, 2024. His comments pertain to basin side wall slope and retaining wall.

- D. Township Lighting Consultant** – Comments from the Township Lighting Consultant are contained in Mr. Corey Trumbower’s review dated December 18, 2023. His comments pertain to fixture and pole detail.
- E. Public Works Department** – The comments from the Public Works Department are contained in Manager Herb Bender’s review dated January 3, 2024. His comments pertain to paving disturbance and water meter pit location.
- F. Public Safety Committee** – The Public Safety Commission reviewed the plan at its June 5, 2023 meeting and reported no comments. The Fire Marshal reported no new comments. *The Public Safety Commission is scheduled to review the January 18, 2024 plan set with regard to the most appropriate location for the proposed pedestrian crosswalk on Eck Road.*
- G. Landscape and Shade Tree Commission** – The comments of staff and of the Landscape and Shade Tree commission have been addressed.
- H. Parks and Recreation Board** – The Parks and Recreation Board recommended at their November 13, 2023 meeting that the developer pay fees in lieu of common open space land dedication to meet the open space and recreation requirements of Section 312-36(d)(4) of the Subdivision and Land Development Ordinance. According to the Zoning Data Block on sheet LD-2 of the December 4, 2023 plan set, the plan proposes an additional 106,084 square feet of impervious surface, resulting in a fee of \$26,521.00.
- I. Lehigh Valley Planning Commission** – The comments of the Lehigh Valley Planning Commission are contained in Ms. Bambi Griffin Rivera’s review dated June 16, 2023. Her comments pertain to trailer accommodations, emergency services, development, sidewalks, landscaping, and stormwater. Mr. Geoffrey Reese notes in his stormwater management review dated June 16, 2023 that the drainage plan is inconsistent with the Act 167 Plan requirements.
- J. Lehigh County Conservation District** – The Lehigh County Conservation District notes, in their review dated January 19, 2024, that the applicant’s NPDES Permit application PAD390301 has been determined to be administratively incomplete.
- K. Pennsylvania Department of Environmental Protection** – The applicant is to obtain approvals for the NPDES Permit and Sewage Facilities Planning.
- L. LANTA** – The comments of LANTA have not been received at the time of this writing. The applicant transmitted a copy of the plan on May 18, 2023.
- M. Community Development Department** – The Department’s technical review is dated February 1, 2024 and provides comment pertaining to zoning issues, public safety, shade trees, Open Space, water and sewer utilities, MS4, plan detail, plan recording requirements, waiver request commentary, and Official Map and Comprehensive Plan consistency. *The Zoning Officer’s review of the January 18, 2024 plan set has not been received at the time of this writing.*

**COMMUNITY DEVELOPMENT DEPARTMENT RECOMMENDATION:**

The Department recommends that the Planning Commission take the plan under advisement to afford the applicant the time necessary to address the reviewing agencies' comments. Our recommendation is contingent upon the applicant granting the Township a waiver from the timeframe in which to act upon the plan.

However, should the Planning Commission find the plans sufficient to advance them to the Board of Commissioners we would recommend the applicant comply with the following conditions:

1. That the applicant shall execute subdivision improvement, security, maintenance and indemnification agreements acceptable to the Township and its Solicitor, that sufficient security in a form acceptable to the Township be posted, that such security shall be available for draws/presentation no further than 60 miles from the Township's office, and evidence of insurance coverage in an amount satisfactory to the Township in its sole discretion shall be provided prior to the plan being recorded.
2. That the applicant address to the satisfaction of the Township Engineer, the comments of Mr. Anthony Tallarida, as contained in his reviews dated January 4 and February 2, 2024. The Applicant shall provide to the Community Development Department written confirmation from the appropriate reviewing agency that all applicable comments have been addressed.
3. That the applicant address to the satisfaction of the Township Geotechnical Consultant, the comments of Mr. Chris Taylor, as contained in his review dated January 31, 2024. The Applicant shall provide to the Community Development Department written confirmation from the appropriate reviewing agency that all applicable comments have been addressed.
4. That the applicant address to the satisfaction of the Township Lighting Consultant, the comments of Mr. Corey Trumbower, as contained in his review dated December 18, 2023. The Applicant shall provide to the Community Development Department written confirmation from the appropriate reviewing agency that all applicable comments have been addressed.
5. That the applicant address to the satisfaction of the Community Development Department, the comments of Mr. Gregg Adams, as contained in his review dated February 1, 2024.
6. That the applicant address to the satisfaction of the Zoning Officer, the comments of Ms. Laura Harrier, as contained in her forthcoming review.
7. That the applicant address to the satisfaction of the Public Works Department, the comments of Mr. Herb Bender, as contained in his review dated January 3, 2024. The Applicant shall provide to the Community Development Department written confirmation from the appropriate reviewing agency that all applicable comments have been addressed.
8. That the applicant address the comments of the Public Safety Commission as contained in their forthcoming review.
9. That the applicant complies with the November 16, 2023 recommendation of the Parks and Recreation Board. The Applicant shall provide to the Community Development Department written confirmation from the appropriate reviewing agency that all applicable comments have been addressed. Payment of any Open Space Fee shall be tendered prior to plan recording.
10. That the applicant addresses all issues and obtains all approvals deemed necessary by the South Whitehall Township Board of Commissioners in so far as matters pertaining to the Township's



water and sewer service are concerned. The Applicant shall provide to the Community Development Department written confirmation from the appropriate reviewing agency that all applicable comments have been addressed, including, but not limited to whether water and sewer allocation and tapping fees are required and, if required, the amount each fee will be. Payment of Allocation Fees shall be tendered prior to plan recording. Payment for Tapping Fees shall be tendered prior to Building Permit issuance.

11. That the applicant obtains a review from the Lehigh Valley Planning Commission prior to the plan being presented to the South Whitehall Township Board of Commissioners. The Applicant shall provide to the Community Development Department written confirmation from the appropriate reviewing agency that all applicable comments have been addressed.
12. That the applicant obtains a letter from the Pennsylvania Department of Environmental Protection and/or the Lehigh County Conservation District approving the NPDES Permit application pursuant to Section 312-39(e) of the Subdivision and Land Development Ordinance.
13. That the applicant obtains a letter from the Pennsylvania Department of Environmental Protection approving a sewage facilities planning module or an exemption thereto. The Applicant shall provide to the Community Development Department written confirmation from the appropriate reviewing agency that all applicable comments have been addressed.
14. That the Applicant shall dedicate additional right-of-way for Eck Road to achieve an ultimate right-of-way for a collector road. The dedication shall occur prior to the plan being recorded. The dedication shall be by Deed of Dedication in a form acceptable to the Township Solicitor, and an Opinion of Record Title shall be prepared by applicant's counsel indicating that the dedication is free and clear of liens and encumbrances that would affect the Township's use of said property. The applicant shall furnish to the Township Solicitor a description for the dedication that has been approved by the Township Engineer, and a copy of the current deed for the property showing current ownership and recording information.
15. That the applicant shall dedicate to the Township a utility easement of sufficient size in an area acceptable to the Township for accessing the water meter pit. The dedication shall occur prior to the plan being recorded. The dedication shall be by Deed of Dedication in a form acceptable to the Township Solicitor, and an Opinion of Record Title shall be prepared by applicant's counsel indicating that the dedication is free and clear of liens and encumbrances that would affect the Township's use of said property. The applicant shall furnish to the Township Solicitor a description for the dedication that has been approved by the Township Engineer, and a copy of the current deed for the property showing current ownership and recording information.
16. That the Applicant shall agree, upon satisfactory completion of all storm sewer, water, and sanitary sewer facilities shown on the plan as intended for dedication to the Township, to execute formal Bills of Sale for said facilities, so as to convey said facilities to the Township for nominal consideration.
17. That the applicant will be responsible for making necessary arrangements with the municipality and the public service company involved for street lights as proposed on the plan and approved by the Board of Commissioners and shall further be responsible for providing

utility easements for lighting standards and fixtures, in accordance with Section 312-41(a)(1)(A) of the Subdivision and Land Development Ordinance.

18. That the applicant coordinates with the Township Engineer's office to have addresses assigned to the plan of record.
19. That the applicant shall execute a Declaration of Covenants and Easement for Maintenance of Stormwater Management Facilities prepared by the Township Solicitor for the maintenance of the on-site stormwater management facilities.
20. That the applicant reconciles all open invoices for Township engineering and legal services prior to the plan being recorded.
21. That the plans are to be revised and deemed to be "clean" prior to them being presented to the Board of Commissioners.

**Planning Commission deadline date to act on the plan:**

**February 19, 2024**

**Board of Commissioners deadline date to act on the plan:**

**March 20, 2024**





**1429 Eck Road Outdoor Storage Major Plan 2022-109**  
**Location Map**





**1429 Eck Road Outdoor Storage Major Plan 2022-109**



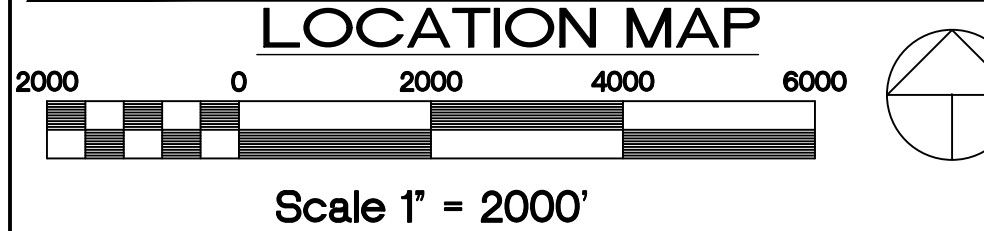
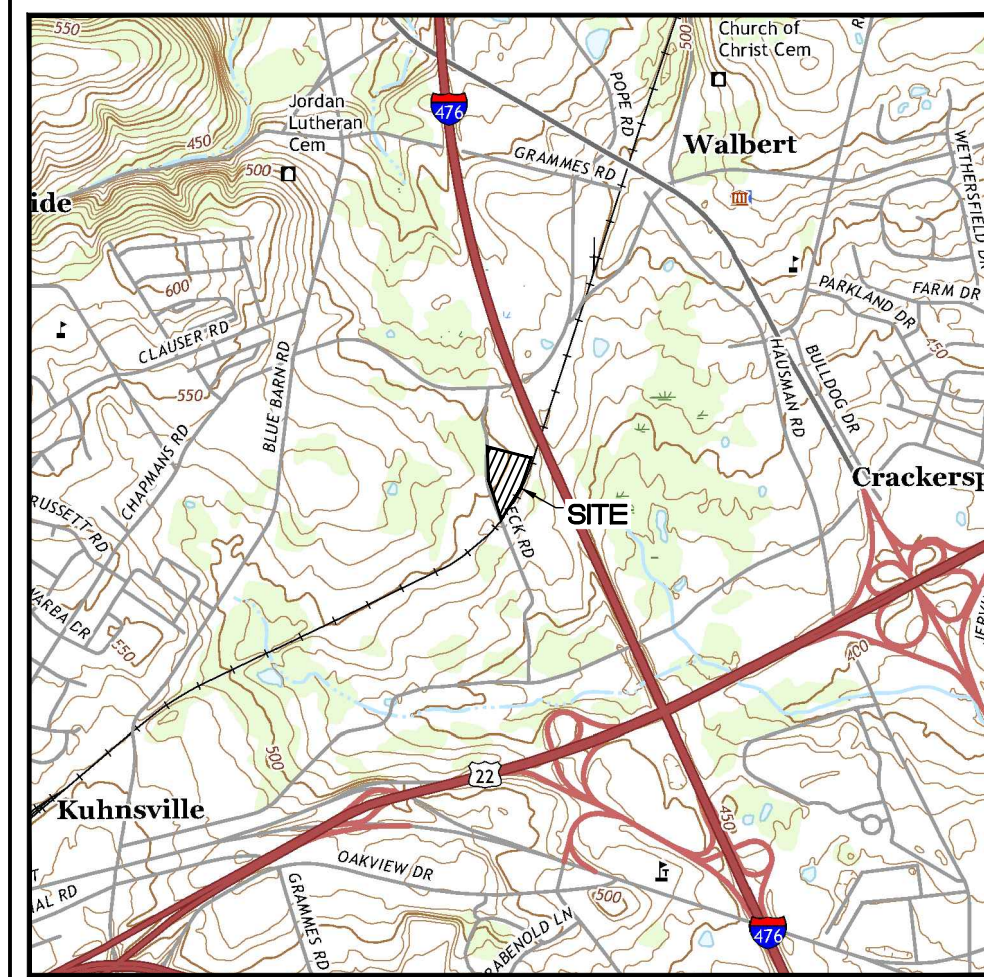

EXISTING SIGN TABULATION					
SYMBOL	SERIES	SIZE	QUANTITY	MESSAGE	REMOVE/RELOCATE
Ⓞ	R8-3	12" x 12"	1	NO PARKING SYMBOL	RELOCATE
Ⓞ	R7-301	12" x 6"	1	ARROW PLAQUE	RELOCATE
Ⓞ	W1-4R	36" x 36"	1	RIGHT REVERSE CURVE ROAD	RELOCATE

\*\* SIGNS TO BE REMOVED OR RELOCATED

SOIL DESCRIPTION TABLE						
SYMBOL	NAME	SLOPE RANGE	CHARACTERISTICS	HYDROLOGIC SOIL GROUP	LIMITATIONS TO USE	RESOLUTIONS TO LIMITATIONS
CmB	CLARKSBURG SILT LOAM	3 TO 8%	MODERATE HAZARD OF EROSION SLOW PERMEABILITY, HIGH AVAILABLE MOISTURE CAPACITY.	C	POSS. SINKHOLE FORMATION; PIPING	SINKHOLE REPAIR; ANTI-SLEEP COLLAR
WaB	WASHINGTON SILT LOAM	3 TO 8%	MODERATE HAZARD OF EROSION MODERATE PERMEABILITY, HIGH AVAILABLE MOISTURE CAPACITY.	B	POSS. SINKHOLE FORMATION; PIPING	SINKHOLE REPAIR; ANTI-SLEEP COLLAR

LEGEND	
EXISTING FEATURES	
2 FT. CONTOUR	
10 FT. CONTOUR	
SPOT ELEVATION	
CONCRETE CURB	
EDGE OF PAVEMENT	
CONCRETE WALK OR PAD	
WOOD GUIDERAIL	
DIRT/GRAVEL ROAD	
STORM SEWER & INLETS	
SANITARY SEWER & MANHOLE	
WATER LINE & VALVE	
OVERHEAD ELECTRIC	
EASEMENT LINE	
PAINT LINES	
PROPERTY LINES	
ADJOINERS' PROPERTY LINES	
RIGHT-OF-WAY	
SIGN POST	
TREE LINE	
DECIDUOUS TREE	
UTILITY POLE	

**NOTE:**  
NO ROCK OUTCROPS, STONE FIELDS, OR OTHER FEATURES OF GROUND  
GROUND SUBSIDENCE PER SALDO SEC 312-12(b)(18) WERE OBSERVED.

Slopes Table				
Number	Minimum Slope	Maximum Slope	Area	Color
1	15.00%	100.00%	245.86	



**SURVEYOR'S STATEMENT**  
I, SCOT A. DIETRICH, A REGISTERED SURVEYOR OF THE COMMONWEALTH OF PENNSYLVANIA, DO HEREBY CERTIFY THAT THE PLAN, PREPARED FROM A FIELD SURVEY ON AUGUST 1, 2022, CORRECTLY REPRESENTS THE PROPERTY BOUNDARY OF THE PROPOSED SUBDIVISION OR LAND DEVELOPMENT.

SIGNED: \_\_\_\_\_  
DATE: \_\_\_\_\_  
COMMONWEALTH OF PENNSYLVANIA  
REGISTERED LAND SURVEYOR NUMBER: SU-053116  
SURVEYOR'S NAME: SCOT DIETRICH  
SURVEYOR'S COMPANY: PANY & LENTZ ENGINEERING COMPANY  
SURVEYOR'S TELEPHONE NO.: 610-433-1634

**PRELIMINARY/FINAL EXISTING FEATURES PLAN**

**PANY & LENTZ ENGINEERING COMPANY**  
CONSULTING ENGINEERS  
CIVIL • STRUCTURAL • MECHANICAL • MACHINERY  
609 Hamilton Street • Allentown, PA 18101  
Office: 610/433-1634 • Fax: 610/433-1636

**1429 ECK ROAD OUTDOOR STORAGE**  
SOUTH WHITEHALL TOWNSHIP  
LEHIGH COUNTY, PENNSYLVANIA

DESIGNED	JAP
DRAWN	BMW
CHECKED	MFS
JOB. NO.	2022258
SCALE	1" = 50' U.N.O.
DATE	MAY 15, 2023
DWG. NO.	LD-4
SHEET NO.	4
REV.	3

J.G. PETRUCCI CO., INC.  
171 ROUTE 173  
SUITE 201  
PETRUCCI DEVELOPMENT • RED BANK, ASBURY, NEW JERSEY 08802

Date: January 17, 2024 - 3:48pm \*Pany & Lentz Engineering Company\* - USER: Brian

**PA ACT 287, AS AMENDED**  
IN ACCORDANCE WITH PA ACT 287, AS AMENDED, THE SURVEYOR CONTACTED PA ONE CALL, INC., FOR A DESIGN PHASE LOCATION REQUEST. THE SERIAL NUMBER FOR THAT REQUEST IS 2022283634. THE SURVEYOR HAS MADE NO INDEPENDENT VERIFICATION OF THE INFORMATION PROVIDED OTHER THAN AS MAY BE READILY EVIDENT FROM THE SURFACE OF THE GROUND.  
THE CONTRACTOR SHALL COMPLY WITH PA ACT 287, AS AMENDED REQUIREMENTS AND VERIFY THE LOCATION OF ALL UTILITIES PRIOR TO THE START OF WORK.



**ENGINEER'S STATEMENT**  
I, STEPHEN A. PANY, A REGISTERED PROFESSIONAL ENGINEER IN THE COMMONWEALTH OF PENNSYLVANIA, DO HEREBY CERTIFY THAT THE ACCOMPANYING APPLICATION, PLANS AND SUPPORTING DOCUMENTATION ARE TRUE AND CORRECT, TO THE BEST OF MY KNOWLEDGE.  
1/18/24 Stephen A. Pany  
DATE PLAN REPAIRER'S SIGNATURE

Pany & Lentz Engineering Company accepts no responsibility for unauthorized use of this document. Reproduction of this drawing or any portion thereof is prohibited without the written consent of Pany & Lentz Engineering Company. Only final construction documents signed and sealed by the Engineer of Record are valid.  
All written dimensions shall take priority over scaled dimensions. The contractor shall be responsible for verifying all locations, elevations, dimensions and conditions prior to construction. The contractor shall notify Pany & Lentz Engineering Company of any discrepancies with the information shown on the drawings.

#	DATE	REVISION	BY
3	01/18/24	ECK ROAD IMPROVEMENTS REVISION	BMW
2	12/04/23	PER TOWNSHIP ENG. REVIEW 10/11/23	BMW
1	09/25/23	PER TOWNSHIP ENG. REVIEW 06/07/23	BMW

**BENCH MARK**  
TOP OF CURB  
ELEV. 496.82 (TOP OF NUT)  
NORTH AMERICAN VERTICAL DATUM 1988

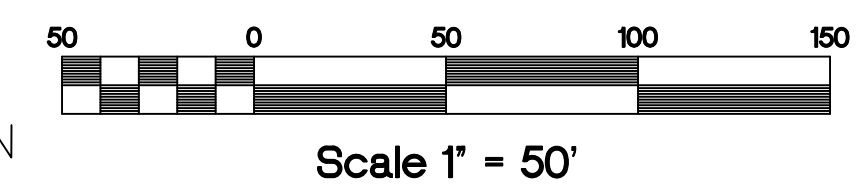



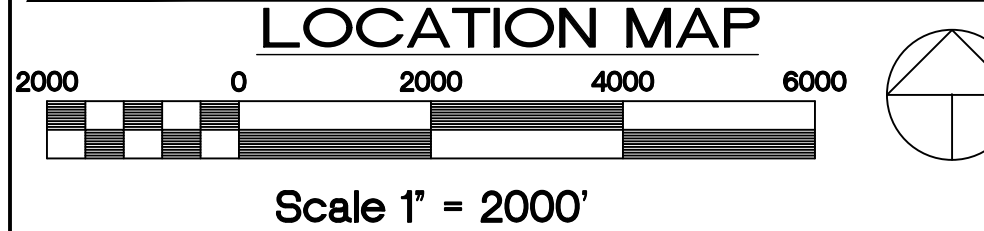
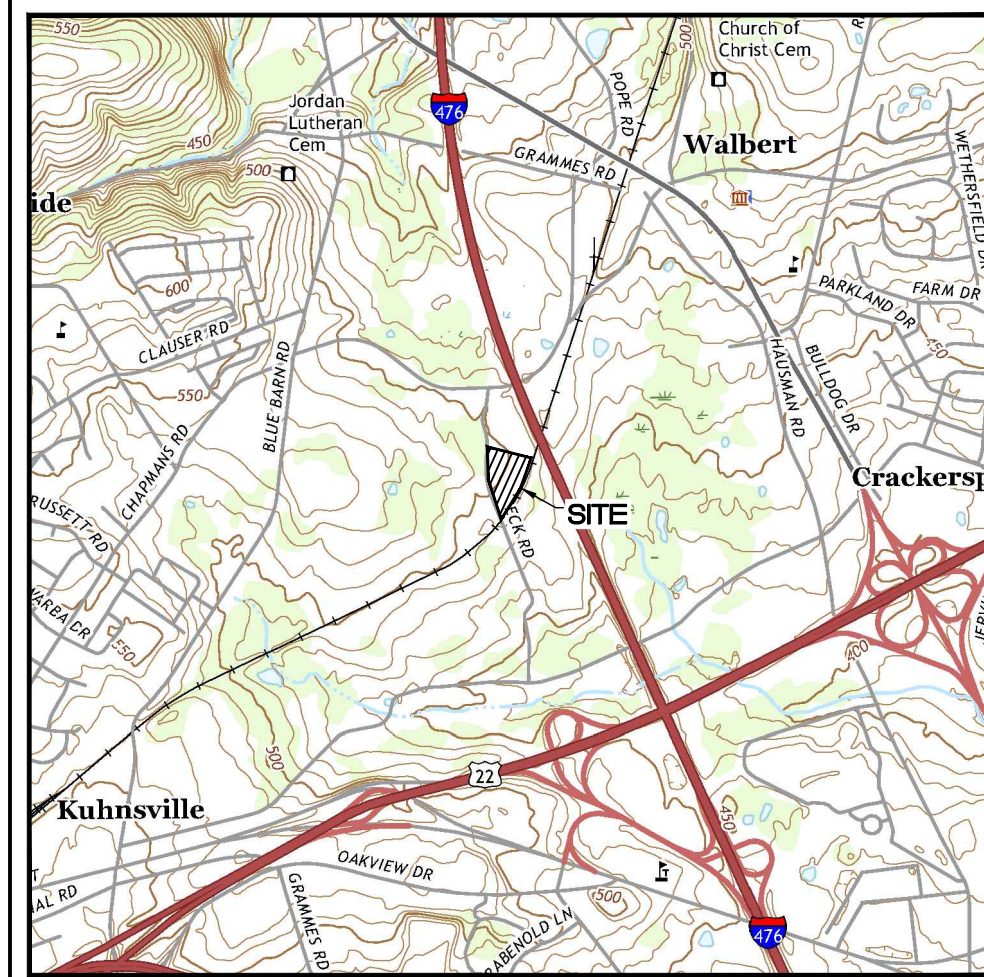

PROPOSED SIGN TABULATION table with columns for SYMBOL, SERIES, SIZE, QUANTITY, and MESSAGE. Includes signs for reserved parking, stop, and right reverse curve.

\*\* SIGNS TO BE BY APPROVED PENNDOT SUPPLIER
\*\* SIGNS TO BE PENNDOT TYPE "B" BREAKAWAY

WAIVER NOTE: THE FOLLOWING WAIVERS FROM SECTIONS OF THE SOUTH WHITEHALL TOWNSHIP SUBDIVISION AND LAND DEVELOPMENT ORDINANCE ARE REQUESTED FOR THIS APPLICATION:

- 1. SECTION 304-27(A) - TO ALLOW EXCAVATION ON THE STREET TO MAKE REQUIRED UTILITY CONNECTIONS.
2. SECTION 312-12(b)(15) - TO NOT SHOW EXISTING AND PROPOSED CONTOURS WITHIN 400 FEET OF SITE.
3. SECTION 312-12(b)(21) - TO NOT SHOW EXISTING SIDEWALK, TRAILS, DRIVEWAYS, STREET, EXTENSIONS, AND RIGHT-OF-WAY, ETC. WITHIN 400 FEET OF SITE.

DEFERRAL NOTE: THE FOLLOWING DEFERRALS FROM SECTIONS OF THE SOUTH WHITEHALL TOWNSHIP SUBDIVISION AND LAND DEVELOPMENT ORDINANCE ARE REQUESTED FOR THIS APPLICATION:

- 1. SECTION 312-26(a) - TO DEFER ECK ROAD FULL WIDTH WIDENING IN FRONT OF PARCEL #547720436370-1

GENERAL DEVELOPMENT NOTES:

- 1. STORMWATER BMPs ARE FIXTURES THAT CANNOT BE ALTERED OR REMOVED WITHOUT APPROVAL BY THE TOWNSHIP AND/OR COUNTY CONSERVATION DISTRICT.
2. ANY PROPOSED SIGNS SHALL BE PERMITTED IN ACCORDANCE WITH COMPLY WITH ZONING ORDINANCE.
3. THE OWNER AGREES TO COMPLY WITH THE APPLICABLE REQUIREMENTS FOR PROPOSED USE(S) AS DETAILED IN ZONING ORDINANCE.

SURVEYORS CERTIFICATION: I HEREBY CERTIFY THE ABOVE PLAN AND SURVEY TO BE CORRECT IN ALL ITS DETAILS.
SCOT A DIETRICH, PLS. DATE
609 HAMILTON STREET, ALLENTOWN, PA 18101, 610-433-1634

BOARD OF COMMISSIONERS APPROVAL: APPROVED: MONTH DAY YEAR BY THE BOARD OF COMMISSIONERS OF THE TOWNSHIP OF SOUTH WHITEHALL.
PRESIDENT SECRETARY
TOWNSHIP ENGINEER
LEHIGH VALLEY PLANNING COMMISSION REVIEW BLOCK: REVIEWED BY LEHIGH VALLEY PLANNING COMMISSION.

RECORDER OF DEEDS: PLAN RECORDED IN THE OFFICE OF THE RECORDER OF DEEDS OF LEHIGH COUNTY, PENNSYLVANIA DOCUMENT ID NUMBER
ON THE DAY OF , 20
WITNESS: RECORDER OF DEEDS

CERTIFICATION OF OWNER OF RECORD: THE APPLICANT IS THE OWNER, EQUITABLE OWNER OR HAS AN OPTION OR CONDITIONAL CONTRACT OF SALE ON THE LAND PROPOSED TO BE SUBDIVIDED OR DEVELOPED, THAT NO LITIGATION OR LIENS EXIST ON OR ARE PENDING AGAINST THE SITE, THAT THE PLAN HAS BEEN PREPARED WITH THE APPLICANT'S FREE CONSENT AND THAT THE APPLICANT DESIRES TO RECORD THE PLAN.

LEGEND: EXISTING FEATURES (CONCRETE CURB, EDGE OF PAVEMENT, CONCRETE WALK OR PAD, EASEMENT LINE, SETBACK LINE, PAINT LINES, PROPERTY LINES, SIGN POST, FENCE, DECIDUOUS/PINE TREE, UTILITY POLE) and PROPOSED FEATURES (CONCRETE CURB, EDGE OF PAVEMENT, CONCRETE WALK OR PAD, FENCE, FUTURE RIGHT-OF-WAY, REMNANT AREA, AREA TO BE MILLED, ROAD WIDENING, LANDSCAPE BERM)

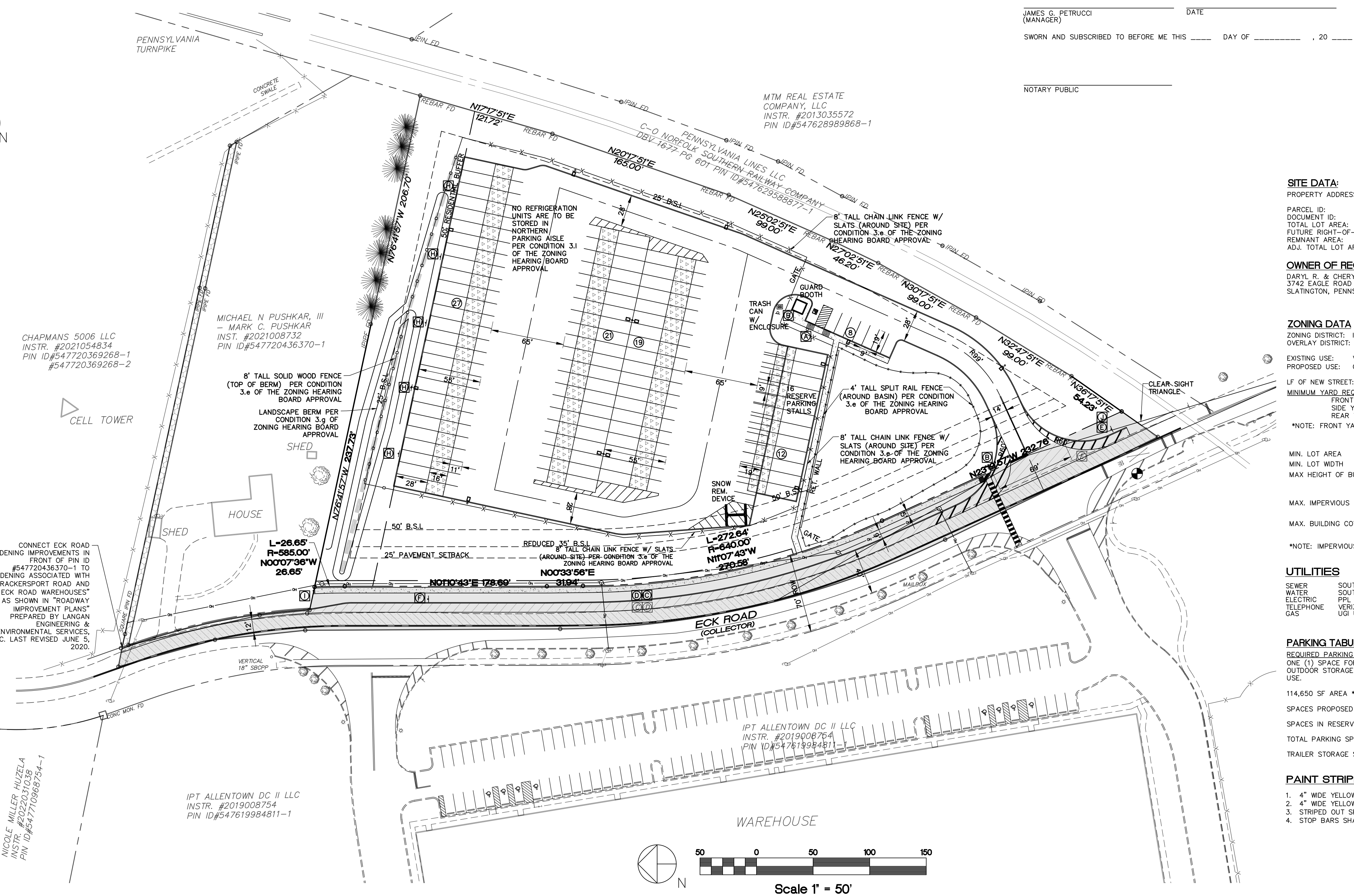

CHAPMANS 5006 LLC INSTR. #2021054834 PIN ID#547720369268-1 #547720369268-2
MICHAEL N PUSHKAR, III - MARK C. PUSHKAR INST. #2021087332 PIN ID#547720436370-1

MTM REAL ESTATE COMPANY, LLC INSTR. #2013035572 PIN ID#54762898968-1
C-O NORFOLK SOUTHERN RAILWAY COMPANY INSTR. #201908764 PIN ID#54761998481-1

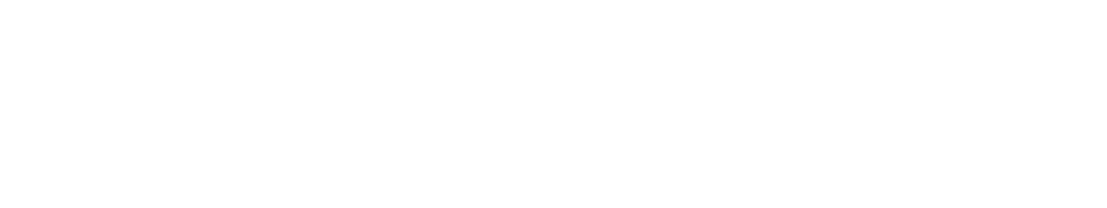

ALL DESIGN AND CONSTRUCTION SHALL BE IN ACCORDANCE WITH THE SOUTH WHITEHALL TOWNSHIP STANDARD SPECIFICATIONS.

SITE DATA: PROPERTY ADDRESS: 1429 ECK ROAD ALLENTOWN, PA 18104
PARCEL ID: 547720402074-1
DOCUMENT ID: 2012024283
TOTAL LOT AREA: 5.112 ACRES
FUTURE RIGHT-OF-WAY: 0.711 ACRES
REMNANT AREA: 0.053 ACRES
ADJ. TOTAL LOT AREA: 4.348 ACRES

EQUITABLE OWNER: TRIPLE NET INVESTMENTS CO, LLC 171 ROUTE 173 - SUITE 201 ASBURY, NEW JERSEY 08802-1365

OWNER OF RECORD: DARYL R. & CHERYL L. LONG 3742 EAGLE ROAD SLATKINGTON, PENNSYLVANIA 18080

DEVELOPER: J.G. PETRUCCI CO. 171 ROUTE 173 - SUITE 201 ASBURY, NEW JERSEY 08802-1365

ZONING DATA: ZONING DISTRICT: IC-1 INDUSTRIAL COMMERCIAL - 1
OVERLAY DISTRICT: TND - INDUSTRIAL RETROFIT AND INFILL

EXISTING USE: VACANT LAND
PROPOSED USE: OUTDOOR STORAGE (SPECIAL EXCEPTION USE)

Table with columns: MIN. LOT AREA, MIN. LOT WIDTH, MAX HEIGHT OF BUILDING, MAX. IMPERVIOUS COVERAGE, MAX. BUILDING COVERAGE. Compares REQUIRED, EXISTING, and PROPOSED values.

UTILITIES: SEWER SOUTH WHITEHALL TOWNSHIP, WATER SOUTH WHITEHALL TOWNSHIP, ELECTRIC VERIZON, PA, TELEPHONE VERIZON, PA, GAS UGI UTILITIES, INC.

PARKING TABULATION: REQUIRED PARKING - OUTDOOR STORAGE. ONE (1) SPACE FOR EVERY 5,000 SQUARE FEET OF ENCLOSED OUTDOOR STORAGE AREA. NOT APPLICABLE IF AN ACCESSORY USE.

SPACES PROPOSED = 8 SPACES
SPACES IN RESERVE = 16 SPACES
TOTAL PARKING SPACES = 24 SPACES
TRAILER STORAGE SPACES = 79 SPACES

PAINT STRIPING NOTES: 1. 4" WIDE YELLOW STRIPING TO BE USED FOR TYPICAL TRAILER SPACE STRIPES.
2. 4" WIDE YELLOW DIAGONAL STRIPING IN "NO PARKING" AREAS.
3. STRIPED OUT SPACE SHALL HAVE STRIPES AT A 45° ANGLE AND 36" C-C SPACING.
4. STOP BARS SHALL BE SOLID WHITE 24" WIDE.

PRELIMINARY/FINAL RECORD PLAN

PANY & LENTZ ENGINEERING COMPANY logo and contact information: 609 Hamilton Street • Allentown, PA 18101. Office: 610/433-1634 • Fax: 610/433-1636. 1429 ECK ROAD SOUTH WHITEHALL TOWNSHIP, LEHIGH COUNTY, PENNSYLVANIA.

PA ACT 287, AS AMENDED: IN ACCORDANCE WITH PA ACT 287, AS AMENDED, THE SURVEYOR CONTACTED PA ONE CALL, INC., FOR A DESIGN PHASE LOCATION REQUEST. THE SERIAL NUMBER FOR THAT REQUEST IS 2022283634. THE SURVEYOR HAS MADE NO INDEPENDENT VERIFICATION OF THE INFORMATION PROVIDED OTHER THAN AS MAY BE READILY EVIDENT FROM THE SURFACE OF THE GROUND.

THE CONTRACTOR SHALL COMPLY WITH PA ACT 287, AS AMENDED REQUIREMENTS AND VERIFY THE LOCATION OF ALL UTILITIES PRIOR TO THE START OF WORK.

ENGINEER'S STATEMENT: I, STEPHEN A. PANY, A REGISTERED PROFESSIONAL ENGINEER IN THE COMMONWEALTH OF PENNSYLVANIA, DO HEREBY CERTIFY THAT THE ACCOMPANYING APPLICATION, PLANS AND SUPPORTING DOCUMENTATION ARE TRUE AND CORRECT, TO THE BEST OF MY KNOWLEDGE.

1/18/24 Stephen A. Pany DATE PLAN PREPARER'S SIGNATURE

Revision table with columns: #, DATE, REVISION, BY. Includes entries for ECK ROAD IMPROVEMENTS REVISION and PER TOWNSHIP ENG. REVIEW.

Design and revision table with columns: DESIGNED, DRAWN, CHECKED, JOB. NO., SCALE, DATE, DWG. NO., SHEET NO., REV., OF. Includes entry for J.G. PETRUCCI CO., INC.

Vertical text on the left margin: Pany & Lentz Engineering Company - USER: Brian, Date: January 17, 2024 - 3:47pm, Record Plan, Rev: 02, Scale: 1" = 50' U.N.O.



CLOSURE REPORT REMNANT AREA

NORTH: 470174.2162' EAST: 2572190.3000'
SEGMENT #1: LINE COURSE: S11° 38' 39"E LENGTH: 5.63'
SEGMENT #2: LINE COURSE: S11° 38' 39"E LENGTH: 118.89'
SEGMENT #3: LINE COURSE: S4° 46' 57"E LENGTH: 44.39'
SEGMENT #4: LINE COURSE: N76° 41' 57"W LENGTH: 18.37'
SEGMENT #5: LINE COURSE: N4° 49' 52"W LENGTH: 80.31'
SEGMENT #6: LINE COURSE: N14° 25' 12"W LENGTH: 88.58'
SEGMENT #7: LINE COURSE: S77° 51' 18"E LENGTH: 18.28'
PERIMETER: 374.45' AREA: 2588.46 SQ. FT.
ERROR CLOSURE: 0.0046 COURSE: N68° 47' 31"E
ERROR NORTH: 0.00167 EAST: 0.00430
PRECISION 1: 81402.17 CONTAINING 0.053 ACRES

CLOSURE REPORT OUTBOUND AREA

NORTH: 468313.7068' EAST: 2572759.6712'
SEGMENT #1: LINE COURSE: N23° 19' 57"W LENGTH: 232.76'
SEGMENT #2: CURVE LENGTH: 272.64' RADIUS: 640.00'
SEGMENT #3: LINE COURSE: N0° 33' 56"E LENGTH: 31.94'
SEGMENT #4: LINE COURSE: N1° 10' 43"E LENGTH: 178.69'
SEGMENT #5: CURVE LENGTH: 26.65' RADIUS: 585.00'
SEGMENT #6: LINE COURSE: S76° 41' 57"E LENGTH: 237.73'
SEGMENT #7: LINE COURSE: S76° 41' 57"E LENGTH: 206.70'
SEGMENT #8: LINE COURSE: S17° 17' 51"W LENGTH: 121.72'
SEGMENT #9: LINE COURSE: S20° 17' 51"W LENGTH: 165.00'
SEGMENT #10: LINE COURSE: S25° 02' 51"W LENGTH: 99.00'
SEGMENT #11: LINE COURSE: S27° 02' 51"W LENGTH: 46.20'
SEGMENT #12: LINE COURSE: S30° 17' 51"W LENGTH: 99.00'
SEGMENT #13: LINE COURSE: S32° 47' 51"W LENGTH: 99.00'
SEGMENT #14: LINE COURSE: S36° 17' 51"W LENGTH: 54.23'
PERIMETER: 1871.26' AREA: 189396.53 SQ. FT.
ERROR CLOSURE: 0.0028 COURSE: N69° 42' 10"E
ERROR NORTH: 0.00097 EAST: 0.00262
PRECISION 1: 667571.43 CONTAINING 4.348 ACRES

CLOSURE REPORT DEDICATED AREA

NORTH: 470230.1567' EAST: 2572532.2992'
SEGMENT #1: LINE COURSE: N0° 52' 13"E LENGTH: 225.36'
SEGMENT #2: LINE COURSE: N4° 49' 52"W LENGTH: 80.31'
SEGMENT #3: LINE COURSE: N14° 25' 12"W LENGTH: 88.58'
SEGMENT #4: LINE COURSE: S77° 51' 19"E LENGTH: 18.28'
SEGMENT #5: LINE COURSE: S11° 38' 39"E LENGTH: 5.63'
SEGMENT #6: LINE COURSE: S11° 38' 39"E LENGTH: 118.89'
SEGMENT #7: LINE COURSE: S4° 46' 57"E LENGTH: 44.39'
SEGMENT #8: LINE COURSE: S76° 41' 57"E LENGTH: 20.85'
SEGMENT #9: CURVE LENGTH: 26.65' RADIUS: 585.00'
SEGMENT #10: LINE COURSE: S11° 10' 46"W LENGTH: 178.69'
SEGMENT #11: LINE COURSE: S0° 33' 38"W LENGTH: 31.94'
SEGMENT #12: CURVE LENGTH: 272.64' RADIUS: 639.88'
SEGMENT #13: LINE COURSE: S23° 19' 55"E LENGTH: 232.76'
SEGMENT #14: LINE COURSE: S36° 17' 51"W LENGTH: 39.16'
SEGMENT #15: LINE COURSE: N24° 37' 16"W LENGTH: 208.85'
SEGMENT #16: CURVE LENGTH: 352.22' RADIUS: 791.67'
PERIMETER: 1945.20' AREA: 30956.97 SQ. FT.
ERROR CLOSURE: 0.0032 COURSE: S50° 29' 46"W
ERROR NORTH: -0.00202 EAST: -0.00245
PRECISION 1: 606325.00 CONTAINING 0.711 ACRES

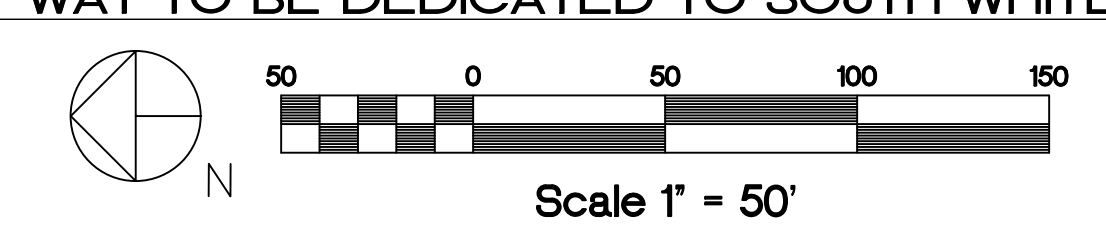
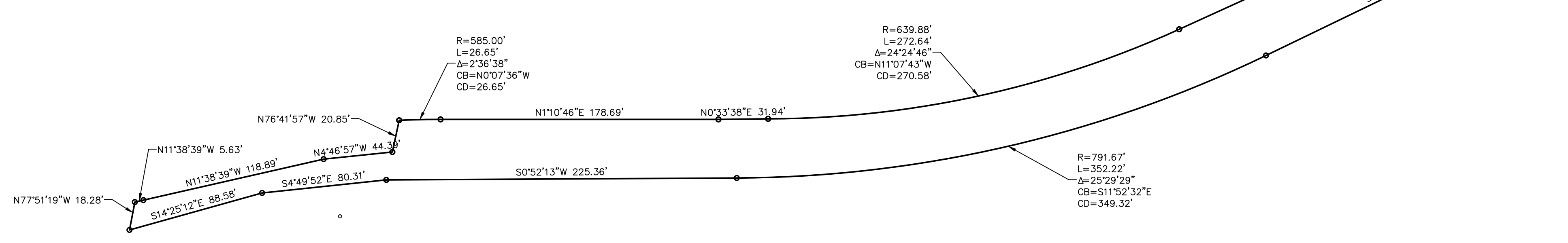
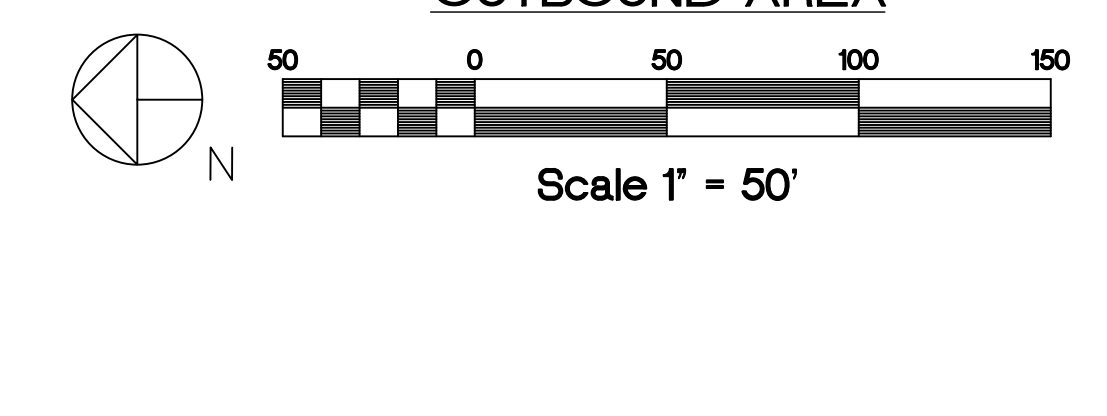
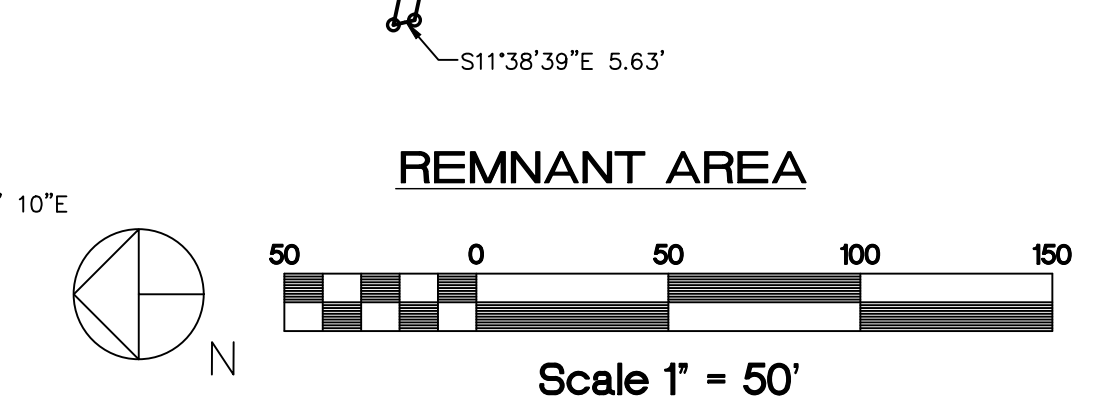
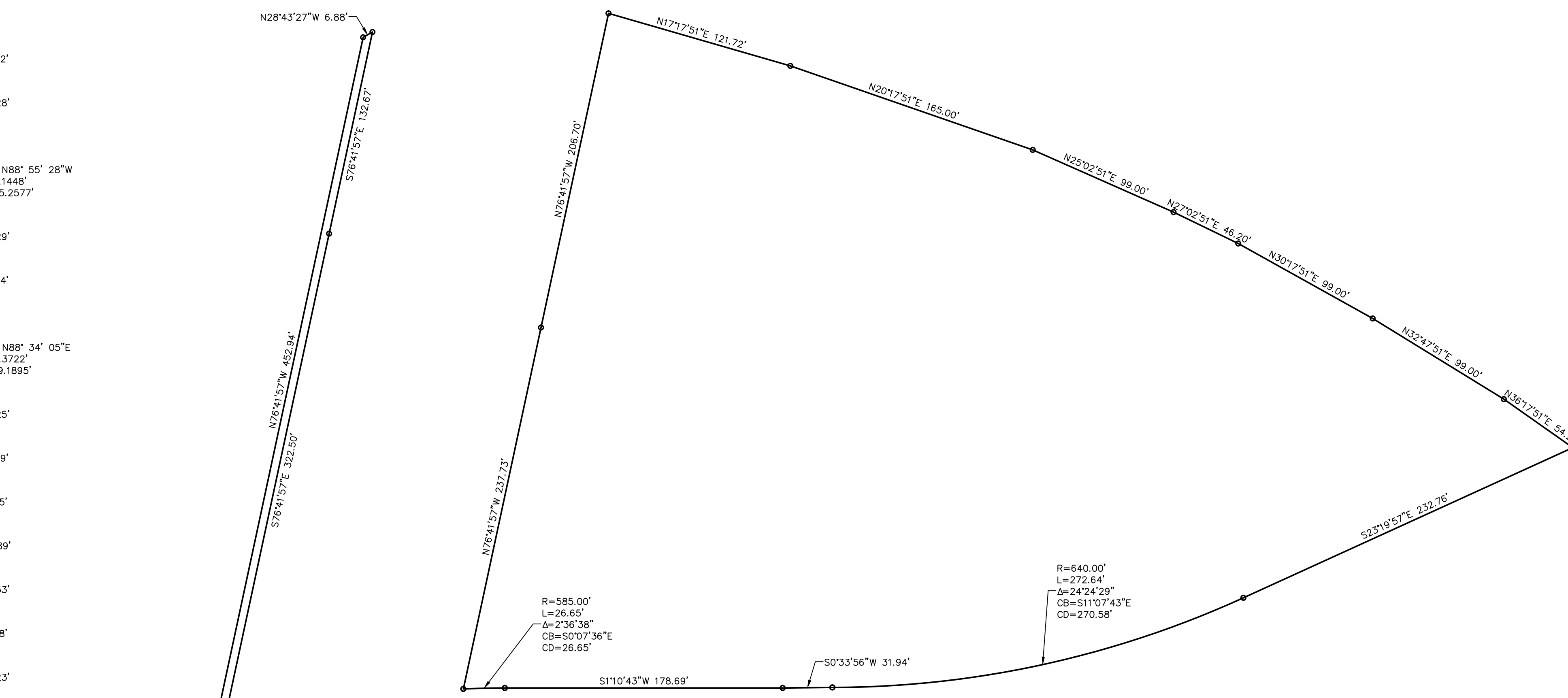

CERTIFICATION OF OWNER OF RECORD

THE APPLICANT IS THE OWNER, EQUITABLE OWNER OR HAS AN OPTION OR CONDITIONAL CONTRACT OF SALE ON THE LAND PROPOSED TO BE SUBDIVIDED OR DEVELOPED, THAT NO LITIGATION OR LIENS EXIST ON OR ARE PENDING AGAINST THE SITE, THAT THE PLAN HAS BEEN IN PROCESS WITH THE APPLICANT'S FREE CONSENT AND THAT THE APPLICANT DESIRES TO RECORD THE PLAN.
THE APPLICANT CERTIFIES THAT HE WILL PROPERLY GRADE ALL INDIVIDUAL LOTS TO PROVIDE ADEQUATE SURFACE DRAINAGE SO THAT NO LOW SPOTS OR WATER POCKETS CREATE A PUBLIC NUISANCE AND THAT HE WILL PLACE PERMANENT CONCRETE REFERENCE MONUMENTS TO GRADE AS NOTED ON THE PLAN UPON COMPLETION OF GRADING.
THE APPLICANT ACKNOWLEDGES THAT FOLLOWING APPROVAL OF THIS PLAN, PLAN CHANGES MAY BE REQUIRED TO ADDRESS THE COMMENTS AND REGULATIONS OF OUTSIDE AGENCIES RESPONSIBLE TO REVIEW ANY ASPECT OF THE PROJECT REFLECTED ON THIS PLAN, INCLUDING BUT NOT LIMITED TO POST-CONSTRUCTION STORMWATER MANAGEMENT AND NPDES PERMIT REGULATIONS. IN THE EVENT OF CHANGES TO THE PLAN FOLLOWING APPROVAL (WHETHER OR NOT THE PLAN HAS BEEN RECORDED), THE APPLICANT SHALL SUBMIT THE REVISED PLAN TO THE TOWNSHIP FOR REVIEW BEFORE THE APPLICANT MAY MOVE FORWARD WITH CONSTRUCTION ACTIVITIES PURSUANT TO THE REVISED PLAN (WHETHER OR NOT THE PLAN HAS BEEN RECORDED).

JAMES G. PETRUCCI (MANAGER) DATE
SWORN AND SUBSCRIBED TO BEFORE ME THIS DAY OF 20

NOTARY PUBLIC

SURVEYORS CERTIFICATION

I HEREBY CERTIFY THE ABOVE PLAN AND SURVEY TO BE CORRECT IN ALL ITS DETAILS.
SCOT A. DIETRICH, PLS DATE
PA 50033116
609 HAMILTON STREET
ALLEN TOWNSHIP, PA 18101
610-433-1634

PLANNING COMMISSION APPROVAL

RECOMMENDED FOR APPROVAL BY THE SOUTH WHITEHALL TOWNSHIP PLANNING COMMISSION. DATE
CHAIRMAN'S SIGNATURE SECRETARY'S SIGNATURE

BOARD OF COMMISSIONERS APPROVAL

APPROVED: MONTH DAY YEAR BY THE BOARD OF COMMISSIONERS OF THE TOWNSHIP OF SOUTH WHITEHALL.
PRESIDENT SECRETARY

TOWNSHIP ENGINEER

LEHIGH VALLEY PLANNING COMMISSION REVIEW BLOCK

REVIEWED BY LEHIGH VALLEY PLANNING COMMISSION.
PLANNER DATE

RECORDER OF DEEDS

PLAN RECORDED IN THE OFFICE OF THE RECORDER OF DEEDS OF LEHIGH COUNTY, PENNSYLVANIA DOCUMENT ID NUMBER
ON THE DAY OF 20
WITNESS MY HAND AND SEAL OF OFFICE THIS DAY OF 20
WITNESS: RECORDER OF DEEDS

PRELIMINARY/FINAL LOT LINE ADJUSTMENT PLAN

PANY & LENTZ ENGINEERING COMPANY CONSULTING ENGINEERS
609 Hamilton Street • Allentown, PA 18101
Office: 610/433-1634 • Fax: 610/433-1636
1429 ECK ROAD OUTDOOR STORAGE SOUTH WHITEHALL TOWNSHIP LEHIGH COUNTY, PENNSYLVANIA

ALL DESIGN AND CONSTRUCTION SHALL BE IN ACCORDANCE WITH THE SOUTH WHITEHALL TOWNSHIP STANDARD SPECIFICATIONS.

ENGINEER'S STATEMENT

I, STEPHEN A. PANY, A REGISTERED PROFESSIONAL ENGINEER IN THE COMMONWEALTH OF PENNSYLVANIA, DO HEREBY CERTIFY THAT THE ACCOMPANYING APPLICATION, PLANS AND SUPPORTING DOCUMENTATION ARE TRUE AND CORRECT, TO THE BEST OF MY KNOWLEDGE.
1/18/24 Stephen A. Pany
DATE PLAN PREPARER'S SIGNATURE



Pany & Lentz Engineering Company accepts no responsibility for unauthorized use of this document. Reproduction of this drawing or any portion thereof is prohibited without the written consent of Pany & Lentz Engineering Company. Only final construction documents signed and sealed by the Engineer of Record are valid.
All written dimensions shall take priority over scaled dimensions. The contractor shall be responsible for verifying all locations, elevations, dimensions and conditions prior to construction. The contractor shall notify Pany & Lentz Engineering Company of any discrepancies with the information shown on the drawings.

Table with columns: #, DATE, REVISION, BY. Row 1: 1, 08/25/23, PER TOWNSHIP ENG. REVIEW 06/07/23, BMW. Row 2: 2, 12/04/23, PER TOWNSHIP ENG. REVIEW 10/11/23, BMW. Row 3: 3, 01/18/24, ECK ROAD IMPROVEMENTS REVISION, BMW.

Table with columns: DWG. NO., REV., SHEET NO., OF. Row 1: LD-3, 3, 34. Row 2: J.G. PETRUCCI CO., INC., 171 ROUTE 173, SUITE 201, PETRUCCI DEVELOPMENT, 2000 W. ASBURY, NEW JERSEY 08802.



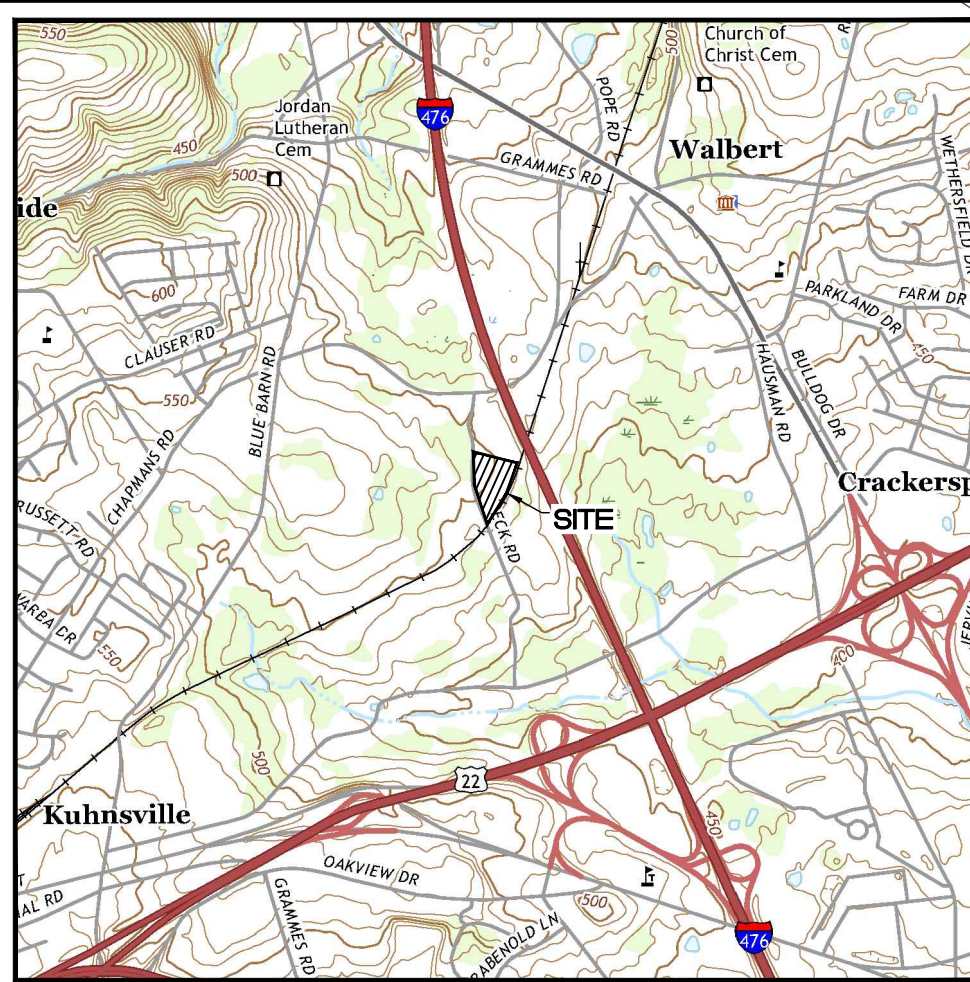

**LOCATION MAP**  
Scale 1" = 2000'

**LEGEND**

EXISTING FEATURES	PROPOSED FEATURES
2 FT. CONTOUR	INTERMEDIATE CONTOUR
10 FT. CONTOUR	2' CONTOUR
SPOT ELEVATION	10' CONTOUR
CONCRETE CURB	SPOT ELEVATION
EDGE OF PAVEMENT	CONCRETE CURB
CONCRETE WALK OR PAD	EDGE OF PAVEMENT
WOOD GUIDERAIL	FENCE (CHAIN LINK)
DIRT/GRAVEL ROAD	FENCE (SPLIT RAIL)
STORM SEWER & INLETS	FENCE (WOOD)
SANITARY SEWER & MANHOLE	CONCRETE WALK OR PAD
WATER LINE & VALVE	STORM SEWER & INLET
OVERHEAD ELECTRIC	SANITARY SEWER & MANHOLE
EASEMENT LINE	WATER LINE & VALVE
PAINT LINES	RIP TRAP APRON
PROPERTY LINES	
ADJOINERS' PROPERTY LINES	
RIGHT-OF-WAY	
SIGN	
SIGN POST	
TREE LINE	
DECIDUOUS TREE	
UTILITY POLE	
WATER TIE	

**PAVING KEY**

HEAVY DUTY PAVEMENT	[Pattern]
LIGHT DUTY PAVEMENT	[Pattern]
CONCRETE PAVEMENT	[Pattern]
SIDEWALK	[Pattern]
ROAD WIDENING	[Pattern]

NOTE: SEE MISCELLANEOUS DETAILS FOR PAVEMENT SPECS.

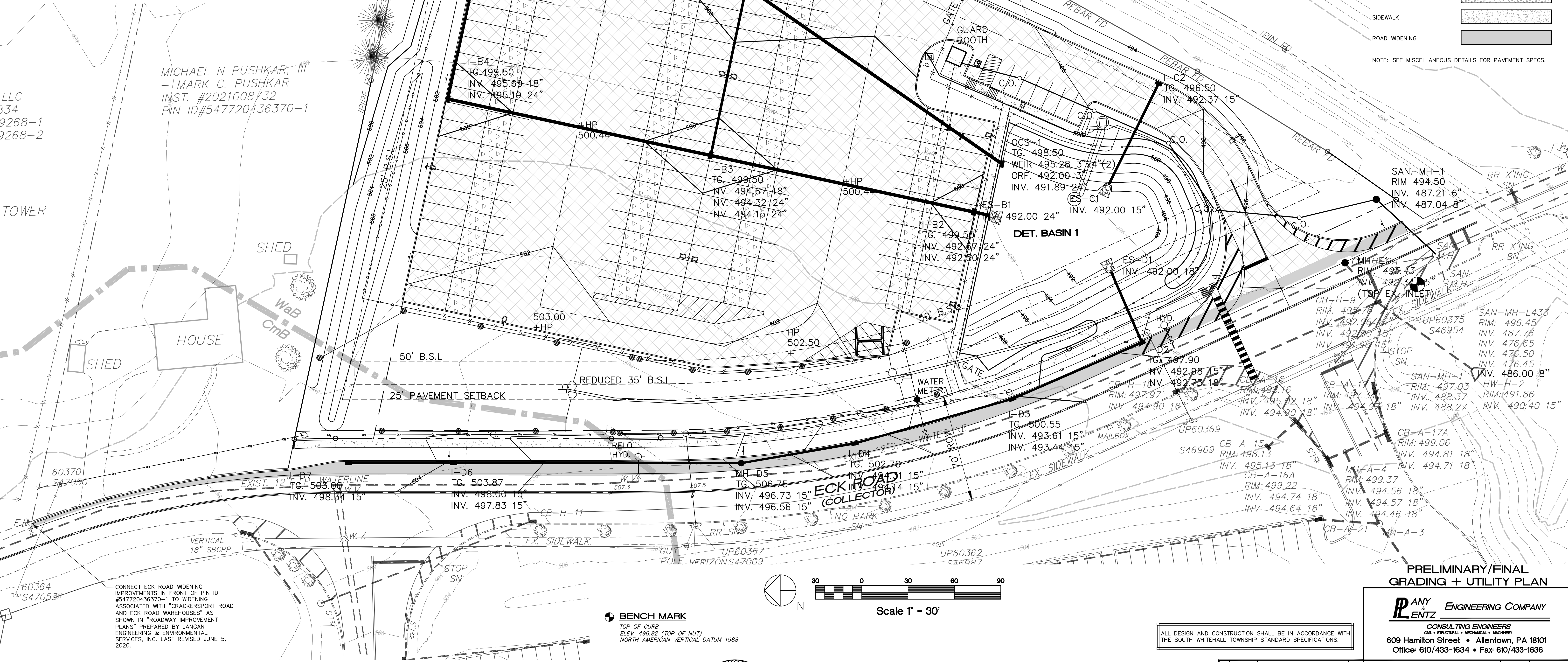

LLC  
834  
9268-1  
9268-2

TOWER

MICHAEL N PUSHKAR, III  
- MARK C. PUSHKAR  
INST. #2021008732  
PIN ID#547720436370-1

Date: January 17, 2024 - 3:48pm \*Pany & Lentz Engineering Company\* - USER: Brian

CONNECT ECK ROAD WIDENING IMPROVEMENTS IN FRONT OF PIN ID #547720436370-1 TO WIDENING ASSOCIATED WITH "CRACKERSPORT ROAD AND ECK ROAD WAREHOUSES" AS SHOWN IN "ROADWAY IMPROVEMENT PLANS" PREPARED BY LANGAN ENGINEERING & ENVIRONMENTAL SERVICES, INC. LAST REVISED JUNE 5, 2020.

**BENCH MARK**  
TOP OF CURB  
ELEV. 496.82 (TOP OF NUT)  
NORTH AMERICAN VERTICAL DATUM 1988

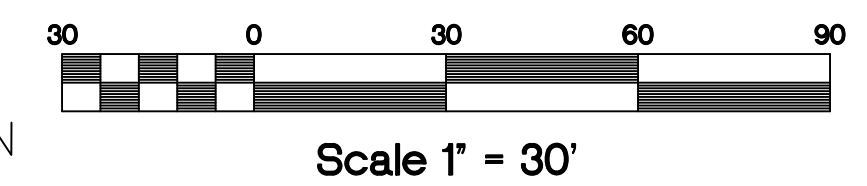

ALL DESIGN AND CONSTRUCTION SHALL BE IN ACCORDANCE WITH THE SOUTH WHITEHALL TOWNSHIP STANDARD SPECIFICATIONS.

**PA ACT 287, AS AMENDED**  
IN ACCORDANCE WITH PA ACT 287, AS AMENDED, THE SURVEYOR CONTACTED PA ONE CALL, INC., FOR A DESIGN PHASE LOCATION REQUEST. THE SERIAL NUMBER FOR THAT REQUEST IS 2022283634. THE SURVEYOR HAS MADE NO INDEPENDENT VERIFICATION OF THE INFORMATION PROVIDED OTHER THAN AS MAY BE READILY EVIDENT FROM THE SURFACE OF THE GROUND.  
THE CONTRACTOR SHALL COMPLY WITH PA ACT 287, AS AMENDED REQUIREMENTS AND VERIFY THE LOCATION OF ALL UTILITIES PRIOR TO THE START OF WORK.



**ENGINEER'S STATEMENT**  
I, STEPHEN A. PANY, A REGISTERED PROFESSIONAL ENGINEER IN THE COMMONWEALTH OF PENNSYLVANIA, DO HEREBY CERTIFY THAT THE ACCOMPANYING APPLICATION, PLANS AND SUPPORTING DOCUMENTATION ARE TRUE AND CORRECT, TO THE BEST OF MY KNOWLEDGE.  
1/18/24 Stephen A. Pany  
DATE PLAN PREPARER'S SIGNATURE

Pany & Lentz Engineering Company accepts no responsibility for unauthorized use of this document. Reproduction of this drawing or any portion thereof is prohibited without the written consent of Pany & Lentz Engineering Company. Only final construction documents signed and sealed by the Engineer of Record are valid.  
All written dimensions shall take priority over scaled dimensions. The contractor shall be responsible for verifying all locations, elevations, dimensions and conditions prior to construction. The contractor shall notify Pany & Lentz Engineering Company of any discrepancies with the information shown on the drawings.

#	DATE	REVISION	BY
3	01/18/24	ECK ROAD IMPROVEMENTS REVISION	BMW
2	12/04/23	PER TOWNSHIP ENG. REVIEW 10/11/23	BMW
1	09/25/23	PER TOWNSHIP ENG. REVIEW 06/07/23	BMW

**PRELIMINARY/FINAL GRADING + UTILITY PLAN**

**PANY & LENTZ ENGINEERING COMPANY**  
CONSULTING ENGINEERS  
CIVIL • STRUCTURAL • MECHANICAL • MAGNETRY  
609 Hamilton Street • Allentown, PA 18101  
Office: 610/433-1634 • Fax: 610/433-1636

DESIGNED	DRAWN	CHECKED	JOB. NO.	SCALE	DATE	DWG. NO.	REV.
			20222836	1" = 50' U.N.I.O.	MAY 15, 2023	LD-5	
							3

**1429 ECK ROAD OUTDOOR STORAGE**  
SOUTH WHITEHALL TOWNSHIP  
LEHIGH COUNTY, PENNSYLVANIA  
J.G. PETRUCCI CO., INC.  
171 ROUTE 173  
SUITE 201  
ASBURY, NEW JERSEY 08802



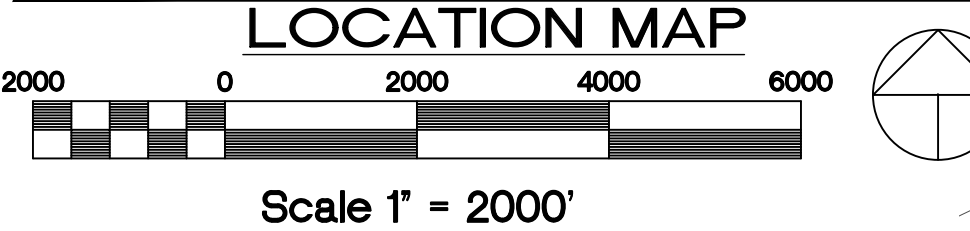
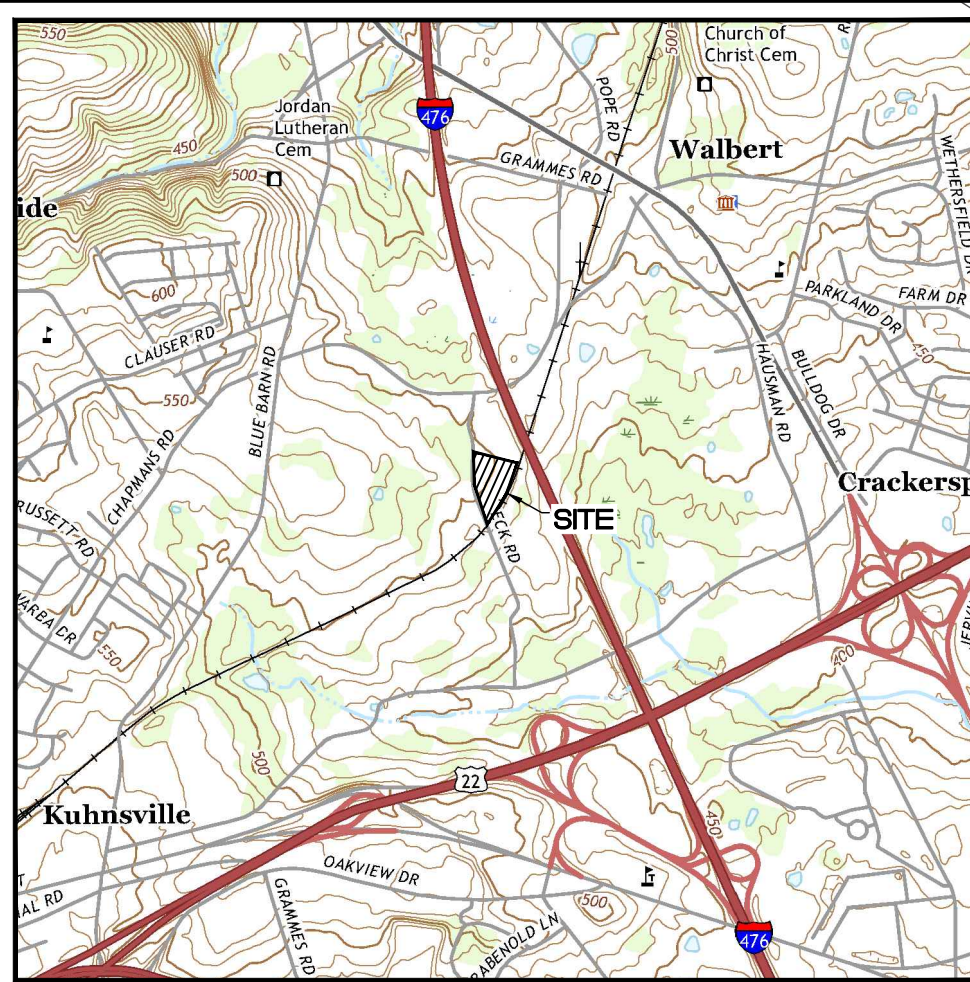

GENERAL PLANTING NOTES:

- 1. THE CONTRACTOR MUST VERIFY LOCATION AND DEPTH OF ALL UNDERGROUND UTILITIES AND FACILITIES PRIOR TO BEGINNING CONSTRUCTION, AS PER ACT 187. CALL 1-800-242-1776.
2. ALL NEW PLANT MATERIAL SHALL BE WARRANTED FOR A PERIOD OF EIGHTEEN MONTHS FROM DATE OF FINAL ACCEPTANCE.
3. THE CONTRACTOR SHALL STAKE OUT THE LOCATIONS OF ALL NEW PLANT MATERIAL FOR REVIEW BY THE LANDSCAPE ARCHITECT PRIOR TO DELIVERY OF PLANT MATERIAL.
4. THE CONTRACTOR SHALL NOT DEVIATE FROM THE PLANT SCHEDULE WITHOUT PRIOR APPROVAL OF THE LANDSCAPE ARCHITECT / OWNER, AND SOUTH WHITEHALL TWP.
5. ALL NON-PAVED AREAS DISTURBED BY CONSTRUCTION ACTIVITIES SHALL BE SEEDED FOR TURF, AS DESCRIBED BELOW, UNLESS OTHERWISE NOTED ON THE PLAN.
6. TURF SEEDING SHALL OCCUR DURING THE SPECIFIED PERIODS. DURING OTHER PERIODS, SEED WITH FORMULA E, RAKE AND RESEED WITH FORMULA B DURING THE NEXT RECOMMENDED PERIOD.
7. PREPARE TURF AREAS PER THE REQUIREMENTS AND DURING THE TIME PERIODS DESCRIBED IN SECTIONS 804 (SEEDING AND SOIL SUPPLEMENTS) AND 805 (MULCHING) OF PennDOT SPECIFICATIONS PUBLICATION 408M IN THE LATEST REVISION. (SEE SPECS BELOW)
8. PLANT MATERIAL LOCATED IN THE VICINITY OF UTILITY ZONES SHALL BE REVIEWED IN THE FIELD PRIOR TO PLANT INSTALLATION.
9. ALL PLANTINGS SHALL BE LOCATED TO AVOID PLACEMENT WITHIN SWALE CENTER LINES.
10. THE CONTRACTOR SHALL SUBMIT PROOF OF PLANT MATERIAL PATENTS WHERE SPECIFIED.

PUSHKAR, III
PUSHKAR
008732
720436370-1

8' TALL SOLID WOOD FENCE (TOP OF BERM) PER CONDITION 3.e OF THE ZONING HEARING BOARD APPROVAL

LANDSCAPE BERM PER CONDITION 3.e OF ZONING HEARING BOARD APPROVAL

8' TALL CHAIN LINK FENCE W/ SLATS (AROUND SITE) PER CONDITION 3.e OF THE ZONING HEARING BOARD APPROVAL

4' TALL SPLIT-RAIL FENCE (AROUND BASIN) PER CONDITION 3.e OF THE ZONING HEARING BOARD APPROVAL

8' TALL CHAIN LINK FENCE W/ SLATS (AROUND SITE) PER CONDITION 3.e OF THE ZONING HEARING BOARD APPROVAL

8' TALL CHAIN LINK FENCE W/ SLATS (AROUND SITE) PER CONDITION 3.e OF THE ZONING HEARING BOARD APPROVAL

MTM REAL ESTATE COMPANY, LLC
INSTR. #2013035572
PIN ID#547628989868-1

C-O NORFOLK SOUTHERN RAILWAY COMPANY
DBV 1677-PG 601 PIN ID#547629588877-1

LEGEND

EXISTING FEATURES

- 2 FT. CONTOUR
10 FT. CONTOUR
SPOT ELEVATION
CONCRETE CURB
EDGE OF PAVEMENT
CONCRETE WALK OR PAD
WOOD GUIDERAIL
DIRT/GRAVEL ROAD
STORM SEWER & INLETS
SANITARY SEWER & MANHOLE
WATER LINE & VALVE
OVERHEAD ELECTRIC
EASEMENT LINE
PAINT LINES
PROPERTY LINES
ADJOINERS' PROPERTY LINES
RIGHT-OF-WAY
SIGN POST
TREE LINE
DECIDUOUS TREE
UTILITY POLE
WATER TIE

PROPOSED FEATURES

- INTERMEDIATE CONTOUR
2' CONTOUR
10' CONTOUR
SPOT ELEVATION
CONCRETE CURB
EDGE OF PAVEMENT
FENCE (CHAIN LINK)
FENCE (SPLIT RAIL)
FENCE (WOOD)
CONCRETE WALK OR PAD
STORM SEWER & INLET
SANITARY SEWER & MANHOLE
WATER LINE & VALVE
RIP TRAP APRON
DECIDUOUS/EVERGREEN TREE
SHRUB

SEEDING LEGEND

- MEADOW/LOW MAINTENANCE SEED MIX
BASIN/WATER TOLERANT SEED MIX

NOTE: SEE LANDSCAPING DETAILS SHEET FOR SEED MIX INFORMATION. STANDARD LAWN SEED MIX TO BE UTILIZED IN AREAS NOT SPECIFIED.

ECK ROAD (COLLECTOR)

PRELIMINARY/FINAL LANDSCAPING PLAN

PANY & LENTZ ENGINEERING COMPANY

CONSULTING ENGINEERS
609 Hamilton Street • Allentown, PA 18101
Office: 610/433-1634 • Fax: 610/433-1636

1429 ECK ROAD
OUTDOOR STORAGE
SOUTH WHITEHALL TOWNSHIP
LEHIGH COUNTY, PENNSYLVANIA

Table with columns: DWG. NO., SHEET NO., REV., DATE, REV. NO., REV. DATE. Includes entry for J.G. PETRUCCI CO., INC.

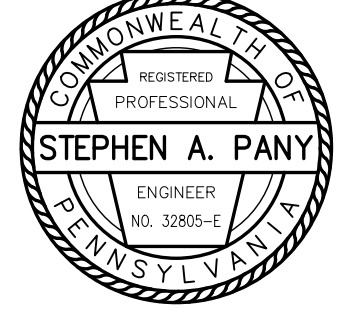

ENGINEER'S STATEMENT

I, STEPHEN A. PANY, A REGISTERED PROFESSIONAL ENGINEER IN THE COMMONWEALTH OF PENNSYLVANIA, DO HEREBY CERTIFY THAT THE ACCOMPANYING APPLICATION, PLANS AND SUPPORTING DOCUMENTATION ARE TRUE AND CORRECT, TO THE BEST OF MY KNOWLEDGE.

1/18/24 Stephen A. Pany
DATE PLAN PREPARER'S SIGNATURE

Pany & Lentz Engineering Company accepts no responsibility for unauthorized use of this document. Reproduction of this drawing or any portion thereof is prohibited without the written consent of Pany & Lentz Engineering Company. Only final construction documents signed and sealed by the Engineer of Record are valid. All written dimensions shall take priority over scaled dimensions. The contractor shall be responsible for verifying all locations, elevations, dimensions and conditions prior to construction. The contractor shall notify Pany & Lentz Engineering Company of any discrepancies with the information shown on the drawings.

ALL DESIGN AND CONSTRUCTION SHALL BE IN ACCORDANCE WITH THE SOUTH WHITEHALL TOWNSHIP STANDARD SPECIFICATIONS.

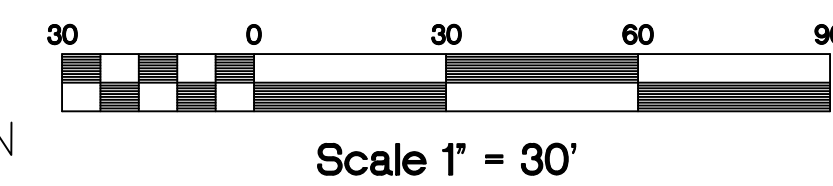

PA ACT 287, AS AMENDED

IN ACCORDANCE WITH PA ACT 287, AS AMENDED, THE SURVEYOR CONTACTED PA ONE CALL, INC., FOR A DESIGN PHASE LOCATION REQUEST. THE SERIAL NUMBER FOR THAT REQUEST IS 2022283634. THE SURVEYOR HAS MADE NO INDEPENDENT VERIFICATION OF THE INFORMATION PROVIDED OTHER THAN AS MAY BE READILY EVIDENT FROM THE SURFACE OF THE GROUND.

THE CONTRACTOR SHALL COMPLY WITH PA ACT 287, AS AMENDED REQUIREMENTS AND VERIFY THE LOCATION OF ALL UTILITIES PRIOR TO THE START OF WORK.

Vertical text on the left margin containing file paths and user information.



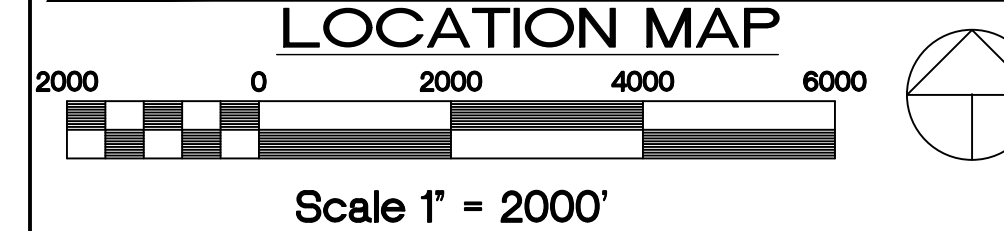
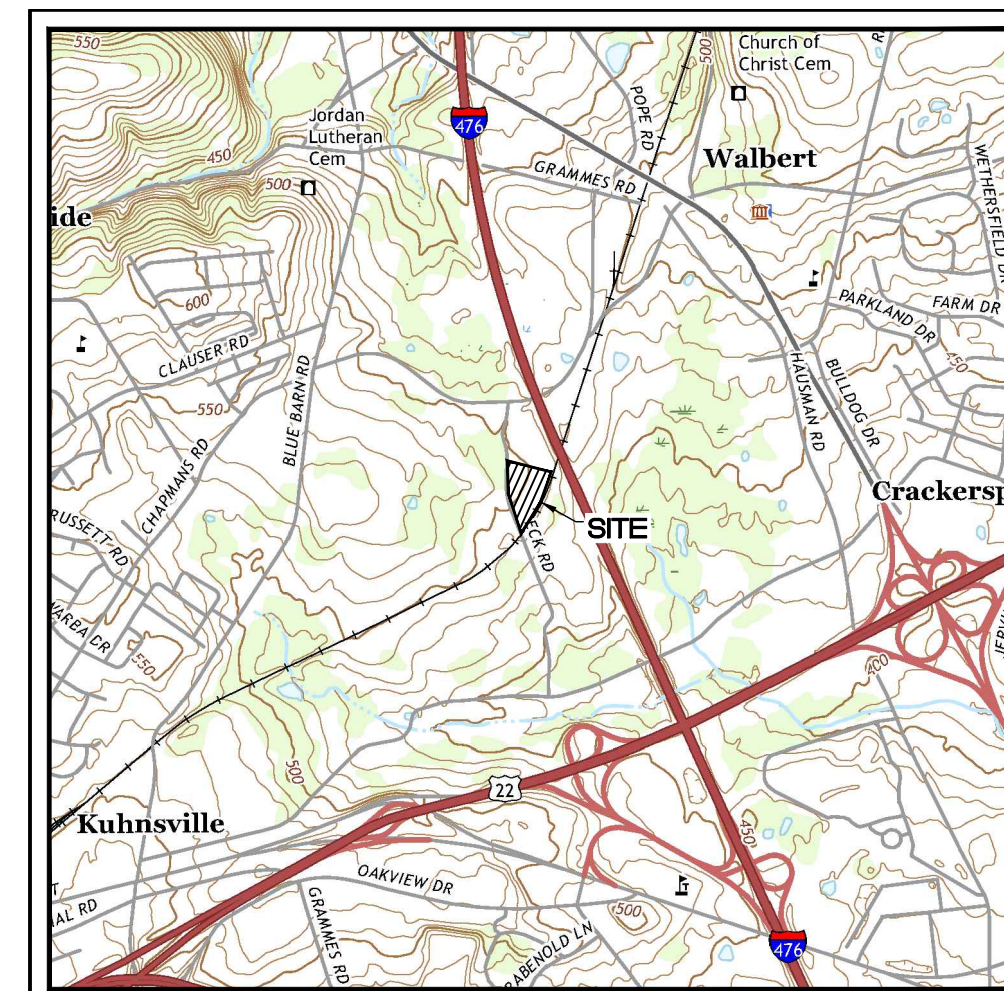

**TECHNICAL INFORMATION — EPA (ft) with 1.3 gust**

Catalog Number	Nominal Shaft Length (ft)	Pole Shaft Size (Base In. x Top In. x Ft.)	Wall thick (in)	Gauge	EPA (ft) with 1.3 gust				Bolt circle (in)	Bolt size (in. x in. x in.)	Approximate ship weight		
					80 MPH	Max. weight	90 MPH	Max. weight				100 MPH	Max. weight
SSS204C	20	4.0x20.0	0.130"	11	9.6	240	6.7	167	4.5	150	8-9	3/4 x 18 x 3	140
SSS204G	20	4.0x20.0	0.130"	7	14	350	11	275	8	200	8-9	3/4 x 18 x 3	198
SSS205C	20	5.0x20.0	0.130"	11	17.7	443	12.7	343	9.4	235	10-12	1 x 36 x 4	185
SSS205G	20	5.0x20.0	0.130"	7	28.1	703	21.4	535	16.2	405	10-12	1 x 36 x 4	265

**Anchor Base Poles**

**SSS**

SQUARE STRAIGHT STEEL



**Specifications**

EPA (ft²@90°): 0.69 ft² (0.06 m²)

Length: 29.3" (74.4 cm) (SPA mount)

Width: 13.4" (34.0 cm)

Height: 3.0" (7.6 cm) Main Body  
7.2" (18.3 cm) Arm

Weight: 30.0 lbs (13.6 kg)

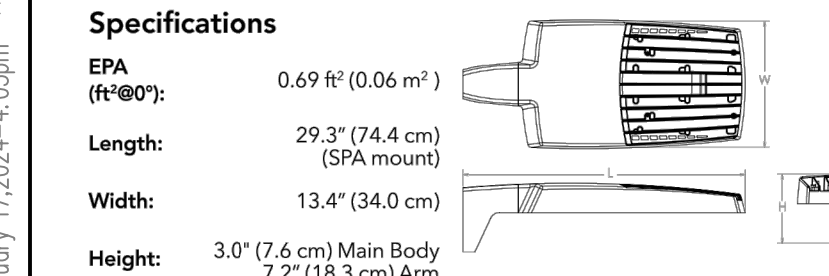

**Options**

Shipped Installed

- W8 Photocell
- PH Photocell, button style
- PER Sensor-wire tie-back (replace only) (no combs)
- SF Single face (120, 277, 347)
- DF Double face (208, 240, 480)
- SPDNV 250V surge pack (UL94 standard)
- FAO Field adjustable arm
- DMG 0-10V dimming extend out back of housing for external control (control ordered separately)
- DS Dual switching

Shipped Installed

- \*Standard and Networked Sensors/Controls (factory default settings, see table page 9)
- INTEGR8 PFRN Light All generations 2, with Networked, 8x Level motion-sensor sensor
- BAA Bay America's) Act Compliant
- CEE Coastal Construction
- \*Note: INTEGR8 PFRN with night air can be used as a standalone dimming sensor with out-of-box settings or as a wireless networked solution. See factory default settings table. Sensor coverage patterns is affected when luminaire is tilted.
- Shipped Separately (requires some field assembly)
- E65 External glare shield
- ES6V External glare shield (200° around light aperture)
- BS Bird spikes

Finish

- DD8D Dark Bronze
- DD8O Black
- DDA0 Natural Aluminum
- DDW0 White
- DD8DZ Textured Dark Bronze
- DD8DO Textured Black
- DDW0DZ Textured Natural Aluminum
- DDW0DZD Textured White

**Ordering Information** EXAMPLE: RSX2 LED P6 40K R3 MVOLT SPA DDBXD

Series	Performance Package	Color Temperature	Distribution	Voltage	Mounting
RSX2 LED	P1	30K 3000K	R2 Type 2 Wide	MVOLT (120V-277V)†	SPA Square pole mounting (11" min. 50 pole for 1 at 90°, 1.5" min. 50 pole for 2, 3, 4 at 90°)
	P2	40K 4000K	R3 Type 3 Wide	MVOLT (120V-480V)†	RPA Round pole mounting (1.2" min. dia. 4" pole for 2, 3, 4 at 90°, 2.1" dia. 4" pole for 1 at 90°, 2 at 180° at 120°)
	P3	50K 5000K	RSS Type 3 Short	MVOLT (120V-480V)†	MA Max arm adaptor (16" x 3/8" OD horizontal) (rem)
	P4		RA Type 4 Wide		IS Adjustable (16" x 3/8" OD) (rem)
	P5		RMS Type 4 Short		WBA Wall bracket
	P6		RS Type 5 Short	120 277	WBASC Wall bracket with surface conduit box
			RSS Type 5 Short	208 347	AASP Adjustable 90° arm square pole mounting
			AFR Automotive Front Row	240 480	AARP Adjustable 90° arm round pole mounting
			AFRR90 Automotive Front Row Right Rotated		AARW Adjustable 90° arm with wall bracket
			AFRL90 Automotive Front Row Left Rotated		ANWSC Adjustable 90° arm wall bracket and surface conduit box

Options	Shipped Installed	Finish
W8 Photocell	*Standard and Networked Sensors/Controls (factory default settings, see table page 9)	DD8D Dark Bronze
PH Photocell, button style	INTEGR8 PFRN Light All generations 2, with Networked, 8x Level motion-sensor sensor	DD8O Black
PER Sensor-wire tie-back (replace only) (no combs)	BAA Bay America's) Act Compliant	DDA0 Natural Aluminum
SF Single face (120, 277, 347)	CEE Coastal Construction	DDW0 White
DF Double face (208, 240, 480)	*Note: INTEGR8 PFRN with night air can be used as a standalone dimming sensor with out-of-box settings or as a wireless networked solution. See factory default settings table. Sensor coverage patterns is affected when luminaire is tilted.	DD8DZ Textured Dark Bronze
SPDNV 250V surge pack (UL94 standard)	Shipped Separately (requires some field assembly)	DD8DO Textured Black
FAO Field adjustable arm	E65 External glare shield	DDW0DZ Textured Natural Aluminum
DMG 0-10V dimming extend out back of housing for external control (control ordered separately)	ES6V External glare shield (200° around light aperture)	DDW0DZD Textured White
DS Dual switching	BS Bird spikes	

**STATISTICS**

Description	Symbol	Avg	Max	Min	Max/Min	Avg/Min
Calc Zone #2	+	2.2 fc	17.9 fc	0.1 fc	179.0:1	22.0:1

**SITE LIGHTING SCHEDULE**

Label	QTY	Catalog Number	Description	Number Lamps	Lumens per Lamp	LLF	Wattage	Mounting Height
A	5	RSX2 LED P5 40K R4 HS	RSX LED AREA LUMINAIRE SIZE 2 P5 LUMEN PACKAGE 4000K CCT TYPE R4 DISTRIBUTION WITH HS SHIELD	1	19,056	0.90	213.48	20'
B	2	RSX2 LED P5 40K R4	RSX LED AREA LUMINAIRE SIZE 2 P5 LUMEN PACKAGE 4000K CCT TYPE R4 DISTRIBUTION WITH HS SHIELD	1	28,993	0.90	426.96	20'
C	4	RSX2 LED P5 40K R3 HS	RSX LED AREA LUMINAIRE SIZE 2 P5 LUMEN PACKAGE 4000K CCT TYPE R3 DISTRIBUTION WITH HS SHIELD	1	20,087	0.90	213.48	20'
POLE	11	-	STEEL, 25'-0", 4"x4" SQUARE POLE, 3/4" BOLT	-	-	-	-	20' (25'+3' BASE)

**EXISTING FEATURES**

- 2 FT. CONTOUR
- 10 FT. CONTOUR
- STORM SEWER & INLETS
- SANITARY SEWER & MANHOLE
- WATER LINE & VALVE
- CONCRETE CURB
- EDGE OF PAVEMENT
- CONCRETE WALK OR PAD
- EASEMENT LINE
- SETBACK LINE
- PAINT LINES
- PROPERTY LINES
- SIGN POST
- FENCE
- DECIDUOUS/PINE TREE
- UTILITY POLE

**LEGEND**

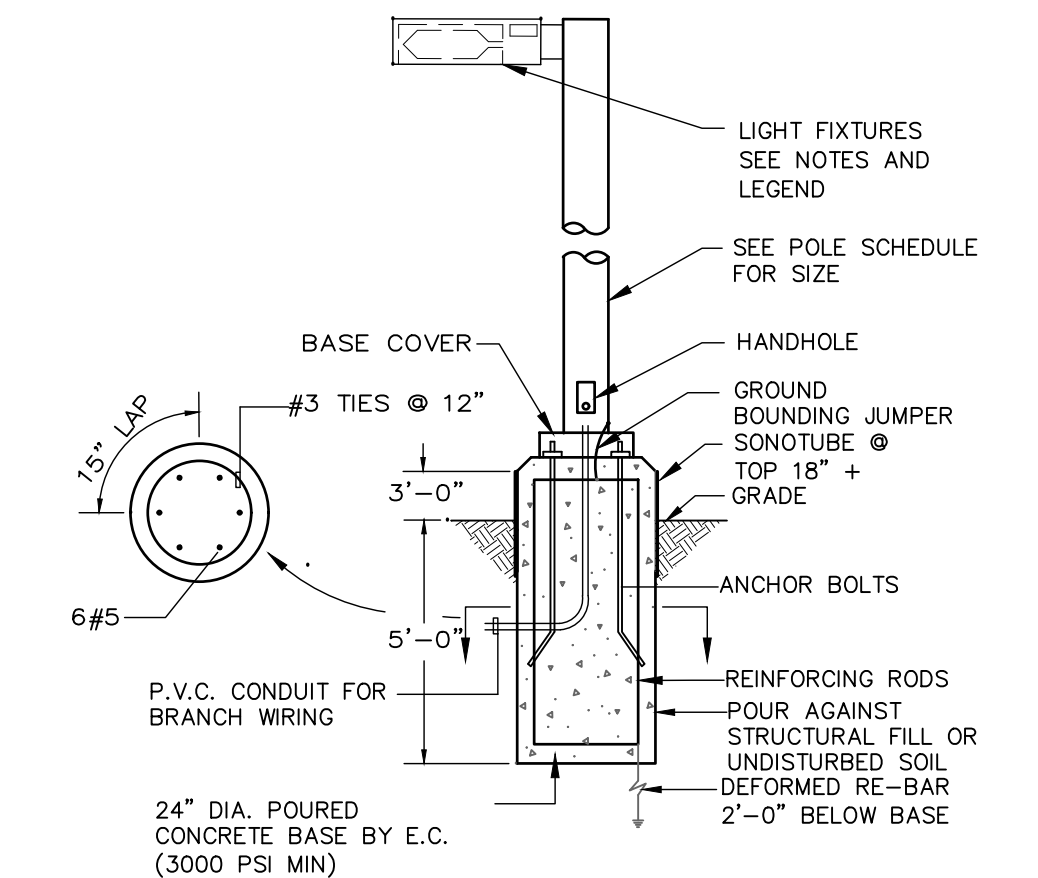
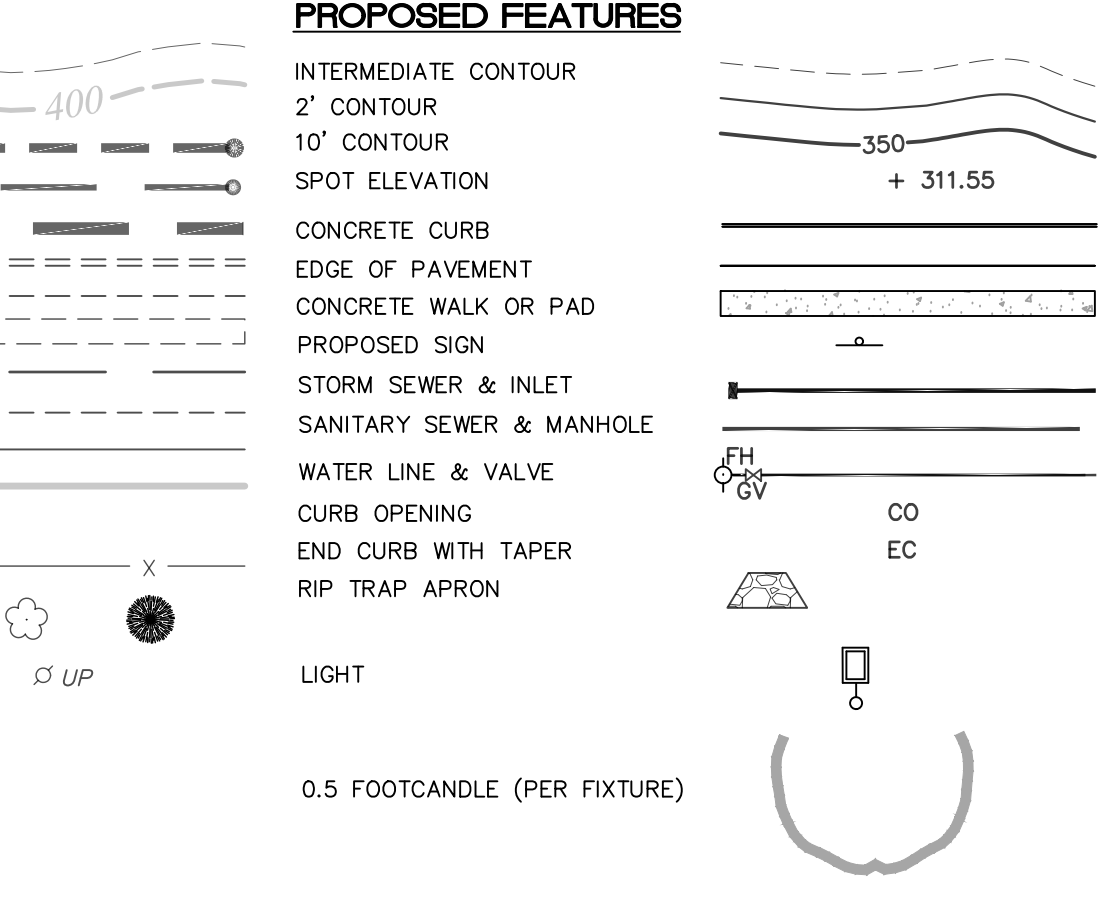

**SITE LIGHT BASE DETAIL**  
NOT TO SCALE  
NOTE: BUILDING PERMIT REQUIRED FOR LIGHT POLE FOUNDATIONS PRIOR TO INSTALLATION.

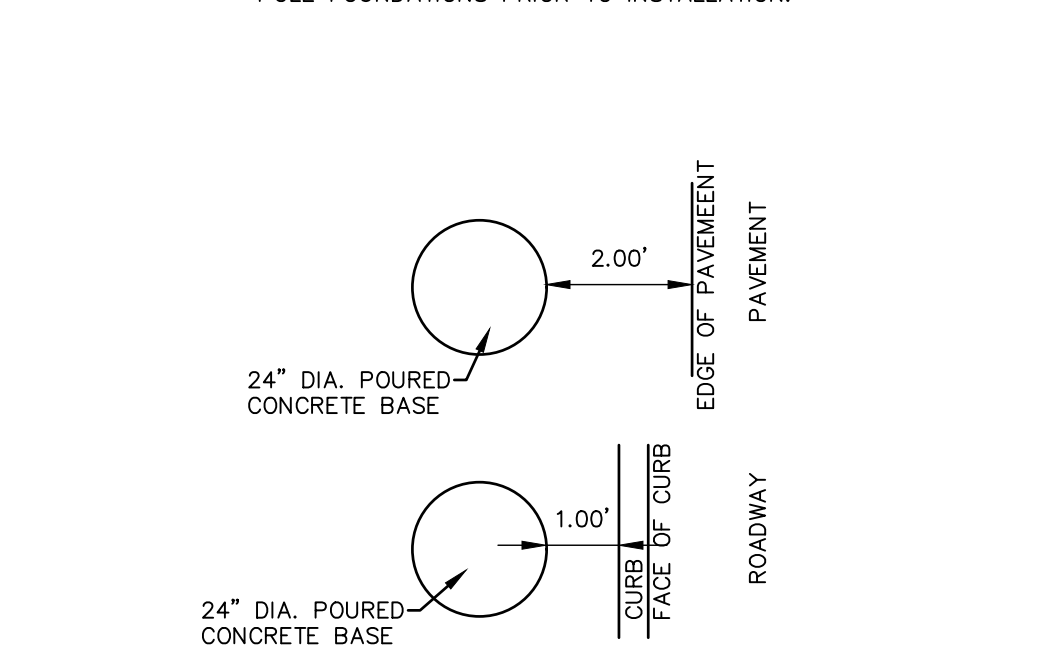

**SITE LIGHT BASE PLACEMENT DETAIL**  
NOT TO SCALE

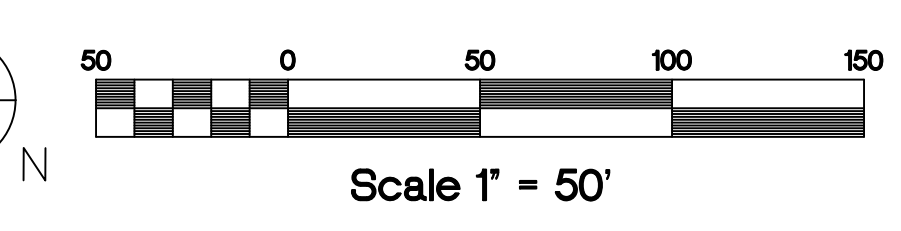

ALL DESIGN AND CONSTRUCTION SHALL BE IN ACCORDANCE WITH THE SOUTH WHITEHALL TOWNSHIP STANDARD SPECIFICATIONS.

**PRELIMINARY/FINAL LIGHTING PLAN**

**PANY & LENTZ ENGINEERING COMPANY**  
CONSULTING ENGINEERS  
CIVIL • STRUCTURAL • MECHANICAL • MAINTENANCE  
609 Hamilton Street • Allentown, PA 18101  
Office: 610/433-1634 • Fax: 610/433-1636

**1429 ECK ROAD OUTDOOR STORAGE**  
SOUTH WHITEHALL TOWNSHIP  
LEHIGH COUNTY, PENNSYLVANIA

J.G. PETRUCCI CO., INC.  
171 ROUTE 173  
SUITE 201  
ASBURY, NEW JERSEY 08802

#	DATE	REVISION	BY
3	01/18/24	ECK ROAD IMPROVEMENTS REVISION	BMW
2	12/04/23	PER TOWNSHIP ENG. REVIEW 10/11/23	BMW
1	09/25/23	PER TOWNSHIP ENG. REVIEW 06/07/23	BMW

DESIGNED	DRAWN	CHECKED	DATE
BMW	BMW	MFS	MAY 15, 2023

**PA ACT 287, AS AMENDED**

IN ACCORDANCE WITH PA ACT 287, AS AMENDED, THE SURVEYOR CONTACTED PA ONE CALL, INC., FOR A DESIGN PHASE LOCATION REQUEST. THE SERIAL NUMBER FOR THAT REQUEST IS 20222283634. THE SURVEYOR HAS MADE NO INDEPENDENT VERIFICATION OF THE INFORMATION PROVIDED OTHER THAN AS MAY BE READILY EVIDENT FROM THE SURFACE OF THE GROUND.

THE CONTRACTOR SHALL COMPLY WITH PA ACT 287, AS AMENDED REQUIREMENTS AND VERIFY THE LOCATION OF ALL UTILITIES PRIOR TO THE START OF WORK.



**ENGINEER'S STATEMENT**

I, STEPHEN A. PANY, A REGISTERED PROFESSIONAL ENGINEER IN THE COMMONWEALTH OF PENNSYLVANIA, DO HEREBY CERTIFY THAT THE ACCOMPANYING APPLICATION, PLANS AND SUPPORTING DOCUMENTATION ARE TRUE AND CORRECT, TO THE BEST OF MY KNOWLEDGE.

1/18/24  
DATE  
Stephen A. Pany  
PLAN PREPARER'S SIGNATURE

Pany & Lentz Engineering Company accepts no responsibility for unauthorized use of this document. Reproduction of this drawing or any portion thereof is prohibited without the written consent of Pany & Lentz Engineering Company. Only final construction documents signed and sealed by the Engineer of Record are valid. All written dimensions shall take priority over scaled dimensions. The contractor shall be responsible for verifying all locations, elevations, dimensions and conditions prior to construction. The contractor shall notify Pany & Lentz Engineering Company of any discrepancies with the information shown on the drawings.

[Location Map] [1429 Eck Road Lighting] [Pany & Lentz Engineering Company] - USER: Brian  
 Date: January 17, 2024 - 4:03pm  
 [Eck Road Lighting] [Pany & Lentz Engineering Company] - USER: Brian  
 Date: January 17, 2024 - 4:03pm  
 [Eck Road Lighting] [Pany & Lentz Engineering Company] - USER: Brian  
 Date: January 17, 2024 - 4:03pm





February 2, 2024

via e-mail

Mr. Gregg R. Adams  
Planner, Community Development Department  
South Whitehall Township  
4444 Walbert Avenue  
Allentown, PA 18104-1699

Re: South Whitehall Township  
1429 Eck Road Outdoor  
Storage  
Major Plan #2022-109  
Preliminary/Final Plan Review

Dear Mr. Adams:

We have reviewed the following information prepared by Pany & Lentz Engineering Company as identified on the attached List of Plans and Supplemental Information. As identified in the Partial Review Response Summary, dated January 18, 2024, we have reviewed only the revised information described. The comments contained in our Memo (attached), dated January 4, 2024, excluding Comments A.1.g, B.1, and D.1, continue to apply and have been attached with this letter. We note the following comments on this partial resubmission:

1. Revise the roadway connection across the Pushkar property to provide a standard roadway transition (minimum of 25:1 taper rate). Extend the full width improvement across the entire development property prior to starting the taper to match the proposed curb line as part of the “Crackersport Road and Eck Road Warehouses” project. We note that the latest plans for this connection area are revised December 9, 2022;

2. Provide proposed grading in the area of roadway widening on the Pushkar property frontage;
3. Revise the Stormwater Management Report to include the proposed improvements along the Pushkar property frontage; and
4. Label the available sight distances for the proposed driveway (based on PennDOT Stopping Sight Distance criteria) on the Record Plan. Provide additional No Parking Signing along Eck Road to maintain the clear sight triangles, SALDO §312-35(a)(6)(F) and §312-12(b)(24).

We note that the proposal requires right-of-way to be dedicated by the adjacent property owner. Documentation has not been provided to date regarding the acceptance of this proposal or dedication of right-of-way. Therefore, we do not recommend engineering approval at this time.

The comments noted above are the result of our engineering review. We have not reviewed items associated with legal, zoning, geotechnical, lighting, water/sanitary sewerage systems, environmental, frontage streetscape improvements, building code, public safety, and other non-engineering issues, and presume that the corresponding data has been forwarded to the appropriate Township Staff and Consultants.



If you have any questions, please contact us.

Very truly yours,

THE PIDCOCK COMPANY



Anthony F. Tallarida, PE  
Manager, Municipal Engineering Services

erb/laf

Enclosures

xc/enc: Mr. Thomas R. Petrucci, MPA, Township Manager  
South Whitehall Township via e-mail  
Mr. David Manhardt, AICP, Director of Community Development  
South Whitehall Township via e-mail  
Mr. Herb Bender, Director of Township Operations  
South Whitehall Township via e-mail  
Mr. Mike Elias, Public Works Utility and MS4 Program Coordinator  
South Whitehall Township via e-mail  
Ms. Tracy J.B. Fehnel, Insurance Administrator & Executive Assistant  
South Whitehall Township via e-mail  
Ms. Laura M. Harrier, BCO, Building Code Official/Zoning Officer  
South Whitehall Township via e-mail  
Mr. John G. Frantz, CFEI, BCO, Fire Marshal, Building Code Official  
South Whitehall Township via e-mail  
Lisa A. Pereira, Esq.  
Broughal & DeVito, LLP via e-mail  
Mr. Christopher A. Taylor, PG, Senior Geologist  
Hanover Engineering Associates, Inc. via e-mail  
Mr. Martin F. Smith, Jr., P.E., Partner - Civil  
Pany & Lentz Engineering Company via e-mail  
Mr. Joseph Petrucci  
Triple Net Insurance CI, LLC via e-mail  
xc: Mr. Ronald J. Gawlik, PE, Township Engineer



South Whitehall Township  
1429 Eck Road Outdoor Storage  
Major Plan #2022-109  
Preliminary/Final Plan Review

List of Plans and Supplemental Information  
Prepared by Pany & Lentz Engineering Company and  
dated or last revised January 18, 2024, except as noted

1. Cover Sheet, Sheet 1 of 34;
2. Record Plan, Sheet 2 of 34;
3. Lot Line Adjustment Plan, Sheet 3 of 34;
4. Existing Features Plan, Sheet 4 of 34 (cursory review only);
5. Grading + Utility Plan, Sheet 5 of 34;
6. Landscape Plan, Sheets 6 of 34 (cursory review only);
7. Landscaping Details, Sheet 7 of 34 (cursory review only);
8. Lighting Plan, Sheet 8 of 34 (cursory review only);
9. Storm Sewer Profiles, Sheet 9 of 34;
10. Storm Sewer Details, Sheets 10 and 11 of 34;
11. Sanitary Sewer Profiles, Sheet 12 of 34 (not reviewed);
12. Sanitary Sewer Details, Sheet 13 of 34 (not reviewed);
13. Waterline Profiles and Details, Sheet 14 of 34 (not reviewed);
14. Eck Road Profile and Details, Sheet 15 of 34; and
15. Miscellaneous Details, Sheets 16 and 17 of 34.

In addition, we have received the following information in support of the Application:

1. Permit Application Fee Invoice, prepared by South Whitehall Township, January 11, 2024;
2. Specifications, prepared by Lithonia Lighting, last revised April 20, 2023;
3. Features & Specifications, prepared by Lithonia Lighting, last revised January 31, 2023;
4. Partial Review Response Summary letter;
5. Subdivision & Land Development Review Application, dated January 17, 2024;
6. Letter of Transmittal to Township; and
7. Revised SALDO Waiver Request letter.

# THE PIDCOCK COMPANY

CIVIL ENGINEERING AND LAND PLANNING

ARCHITECTURE

LAND SURVEYING

Oxford Drive at Fish Hatchery Road  
 2451 Parkwood Drive Allentown, Pennsylvania 18103-9608  
 Telephone: 610-791-2252  
 Telefacsimile: 610-791-1256  
 E-mail: info@pidcockcompany.com  
 Website: www.pidcockcompany.com

Established 1924  
 J. Scott Pidcock, P.E., R.A.

Bruce E. Anderson, P.E., LEED AP  
 Brian A. Dillman, P.E.  
 Ronald J. Gawlik, P.E.  
 Brian E. Harman, P.E., PTOE  
 James A. Rothdeutsch, P.E., LEED AP  
 John R. Russek, Jr., P.E.  
 Brent C. Tucker, P.E.

Douglas E. Haberbosch, P.E.  
 William G. Kmetz, P.L.S.  
 Jeffrey R. Matyus  
 John M. McRoberts, P.E.  
 Brent D. Shriver, P.E.  
 Todd L. Sonntag, R.A., LEED AP  
 Anthony F. Tallarida, P.E.  
 Ryan R. Troutman, P.E.

G. Edwin Pidcock, P.E., P.L.S. 1924-1967  
 John S. Pidcock, P.E., P.L.S. 1954-1999  
 Ralph M. Pidcock, P.L.S. 1952-2000 (Retired)

## MEMORANDUM

**TO:** Mr. Gregg R. Adams via e-mail  
 Planner, Community Development Department  
 South Whitehall Township

**FROM:** Mr. Anthony F. Tallarida, PE *AFT*  
 Manager, Municipal Engineering Services

**SUBJECT:** South Whitehall Township  
 1429 Eck Road Outdoor Storage  
 Major Plan #2022-109  
 Preliminary/Final Plan Review

**DATE:** January 4, 2024

**COPIES:** Mr. Thomas R. Petrucci, MPA  
 Township Manager  
 South Whitehall Township

Mr. David Manhardt, AICP  
 Director of Community Development  
 South Whitehall Township

Mr. Herb Bender  
 Director of Township Operations  
 South Whitehall Township

Mr. Mike Elias  
 Public Works Utility and MS4 Program Coordinator  
 South Whitehall Township

Ms. Tracy J.B. Fehnel  
Insurance Administrator & Executive Assistant  
South Whitehall Township

Ms. Laura M. Harrier, BCO  
Building Code Official/Zoning Officer  
South Whitehall Township

Mr. John G. Frantz, CFEI, BCO  
Fire Marshal, Building Code Official  
South Whitehall Township

Lisa A. Pereira, Esq.  
Broughal & DeVito, LLP

Mr. Christopher A. Taylor, PG  
Senior Geologist  
Hanover Engineering Associates, Inc.

Mr. Geoffrey A. Reese, P.E.  
Master Planner and Engineer  
Lehigh Valley Planning Commission

Mr. Martin F. Smith, Jr., P.E.  
Partner - Civil  
Pany & Lentz Engineering Company

Mr. Joseph Petrucci  
Triple Net Investments CI, LLC

(all via e-mail)

Mr. Ronald J. Gawlik, PE, Township Engineer

South Whitehall Township Ordinances:

Zoning Ordinance (ZO)

Subdivision and Land Development Ordinance (SALDO)

Stormwater Management Plan (SMP)

See attached list for documents reviewed.

Proposal:

Proposed 103-space outdoor storage area (24 vehicle parking spaces (8 proposed; 16 reserve spaces) and 79 tractor-trailer spaces) and 100 square foot (s.f.) guard booth on a 5.1± acre property;

0.8± acres of Right-of-Way to be dedicated to the Township;

Widening, curb, and sidewalk improvements along Eck Road;

One Stormwater Management Facility;

IC-1 (Industrial-Commercial-Special Height Limitation) Zoning District;

TND – Industrial Retrofit and Infill Overlay District;

Proposed Public Water and Public Sewer by South Whitehall Township Authority; and

Outdoor Storage is permitted as a Special Exception Use in IC-1.

Waivers/Deferrals/Variations:

None to date (see Waiver Comment below).

See ZHB-2022-09 Decision for variance information/Special Exception Approval.

Recommendation:

Engineering approval not recommended at this time.

jfw/laf

Enclosures

## THE PIDCOCK COMPANY

South Whitehall Township  
1429 Eck Road Outdoor Storage  
Major Plan #2022-109  
Preliminary/Final Plan Review

January 4, 2024

**REVIEW COMMENTS****A. Planning**

1. As stated in a Waiver Request Letter provided by the Design Engineer, dated December 4, 2023, the following waivers are requested:
  - a. SALDO §304-27(a) – Waiver to allow excavation and opening of a paved surface less than five years old. The Applicant is proposing road widening and utility connections along Eck Road, which is less than five years old. We have no engineering objection to this request;
  - b. SALDO §312-12(b)(15) – Waiver from the requirement of showing existing and proposed contours within 400 feet of the site. The Applicant currently shows contours 200 feet beyond the property line. We have no engineering objection to this request;
  - c. SALDO §312-12(b)(21) – Waiver from the requirement of showing existing sidewalks, trails, driveways, streets, extensions, and right-of-way, etc., within 400 feet of the site. The Applicant currently shows existing features 200 feet beyond the property line. We have no engineering objection to this request;
  - d. SALDO §312-35(b)(8)(B) – Waiver from the requirement to grade beyond the right-of-way line to provide a continuous slope. We note the requested waiver should be §312-35(b)(3)(a)[8][a][ii]. We have no engineering objection to this request;
  - e. SALDO §312-36(c)(5)(A) – Waiver from the requirement that the maximum 40-foot driveway width requirement to allow a driveway width at the right-of-way to be larger than 40 feet (70± feet proposed). We have no engineering objection to this request. Also, we recommend consideration of any comments from the Department of Public Works;
  - f. SALDO §312-39(d)(2) – Waiver from the requirement of basins having a minimum longitudinal slope of two percent. We defer to the Township Geotechnical Consultant regarding minimum basin slopes; and
  - g. SALDO §312-26(a) – Deferral from the requirement to improve Eck Road in front of Parcel #547720436370-1. We do not recommend this deferral. Please refer to comment B.1 below.

All waivers and deferrals in the waiver request letter should be listed on the Plans.

In the event a waiver or deferral is ultimately granted upon submission of Land Development Plans, update the Waiver Note to reflect the dates of approval, and the Board which took the action.

**B. General**

1. Frontage improvements are required on the Pushkar property, SALDO §312-26(a). We recommend curb be placed from the 1429 property to the proposed curb line on the Hauser property. We could support a deferral of the remaining frontage improvements on the Pushkar property;
2. Provide legal descriptions and associated exhibits for all areas to be dedicated to South Whitehall Township;
3. Revise the Location Map on all sheets to match the map shown on the Cover Sheet; and
4. The Township's Accessibility Code Official may have additional review comments during building permitting. We recommend contacting the Code Official to confirm the above comments and any other applicable accessibility requirements.

**C. Stormwater Management**

1. Revise the proposed grading along the northern property line to incorporate a further defined swale to convey runoff within the site. We note that the proposed grading would appear to concentrate runoff to be conveyed across the Pushkar property which would alter the flow characteristics from the site, SALDO §312-39(a)(3);
2. Revise the calculations for Inlets D-6 and D-7 to be consistent with the proposed roadway grading bypass conditions. Consider additional provisions at these inlets to ensure all runoff is captured within the tributary area to Basin 1, SALDO §312-39(b)(10);
3. Clearly identify the intended ownership of and maintenance responsibilities for stormwater management facilities. The maintenance responsibilities for drainage facilities should be discussed between the Township and Developer, and note the specific limits of public/private ownership (e.g., storm sewer, etc.) on a plan to be recorded, SMP §296-38; and
4. A BMP Operations and Maintenance Plan should identify the person responsible and note any applicable easements, SMP §296-38 and §296-40. We note that the Design Engineer states that the PCSM Plans are to be the BMP Operations and Maintenance Plan. This Plan should include a statement, signed by the property owner, acknowledging that stormwater BMPs are fixtures that cannot be altered or removed without approval by the Township, SMP §296-39. Additionally, an Operations and Maintenance Agreement should be executed for the proposed stormwater BMPs, SMP §296-42.

**D. Traffic**

1. Provide required and available sight distances for the proposed driveway (based on PennDOT Stopping Sight Distance criteria) and label the sight triangles on the Record

Plan. Provide No Parking Signing along Eck Road to the north of the driveway to maintain the clear sight triangles, SALDO §312-35(a)(6)(F) and §312-12(b)(24);

2. Relocate the Pedestrian Sign south of the driveway to be on the north side of the driveway at the crosswalk; and
3. Confirm adequate pedestrian sight distance is provided for the proposed crosswalk location.

**E. Policy and Information**

1. The Applicant should discuss with the Township whether open space, or fees in lieu thereof, will be required, and an appropriate note should be placed on the Plan to be recorded, SALDO §312-36(d). Open Space calculations and an Open Space Plan encompassing the entire development should be provided;
2. Copies of all correspondence, including all data submitted to outside agencies regarding required permits and approvals, should be provided to the Township and our office;
3. Any concerns of the Shade Tree Commission related to proposed street tree and landscape plantings should be addressed, SALDO §312-12(b)(28) and §312-12(b)(36);
4. We defer to the Township Electrical Consultant to review the proposed site lighting. The Design Engineer should confirm that the proposed light standard foundations will be adequate to support the proposed light standards;
5. Matters pertaining to the design of water distribution and sanitary sewerage systems should be directed to the Department of Public Works. We have not reviewed these designs; and
6. Upon submission of plans for recording, all Statements and Certifications shall be signed and sealed/notarized as applicable, SALDO §312-14(b)(2). The Township Solicitor should determine the acceptability of the Engineer's Statement, SALDO §312-12(b)(5).

The comments noted above are the result of our engineering review. We have not reviewed items associated with legal, zoning, geotechnical, lighting, water/sanitary sewerage systems, environmental, frontage streetscape improvements, building code, public safety, and other non-engineering issues, which should be reviewed by the appropriate Township Staff and Consultants.



## THE PIDCOCK COMPANY

South Whitehall Township  
1429 Eck Road Outdoor Storage  
Major Plan #2022-109  
Preliminary/Final Plan Review

List of Plans and Supplemental Information  
Prepared by Pany & Lentz Engineering Company and  
dated or last revised December 4, 2023, except as noted

1. Cover Sheet, Sheet 1 of 34;
2. Record Plan, Sheet 2 of 34;
3. Lot Line Adjustment Plan, Sheet 3 of 34;
4. Existing Features Plan, Sheet 4 of 34 (cursory review only);
5. Grading + Utility Plan, Sheet 5 of 34;
6. Landscape Plan, Sheets 6 of 34 (cursory review only);
7. Landscaping Details, Sheet 7 of 34 (cursory review only);
8. Lighting Plan, Sheet 8 of 34 (cursory review only);
9. Storm Sewer Profiles, Sheet 9 of 34;
10. Storm Sewer Details, Sheets 10 and 11 of 34;
11. Sanitary Sewer Profiles, Sheet 12 of 34 (not reviewed);
12. Sanitary Sewer Details, Sheet 13 of 34 (not reviewed);
13. Waterline Profiles and Details, Sheet 14 of 34 (not reviewed);
14. Road Profile & Details, Sheet 15 of 34;
15. Miscellaneous Details, Sheets 16 and 17 of 34;
16. Stormwater Management – Pre-Development Plan, Sheet 18 of 34;
17. Stormwater Management – Post-Development Plan, Sheet 19 of 34;
18. Storm Sewer Drainage Areas Plan, Sheet 20 of 34;
19. Truck Turning Maneuvers WB-67, Sheet 21 of 34;
20. Truck Turning Maneuvers Emergency Vehicle, Sheet 22 of 34;
21. Erosion + Sediment Pollution Control (ESPC) Plan Stage 1, Sheet 23 of 34 (cursory review only);
22. ESPC Plan Stage 2 + 3, Sheet 24 of 34 (cursory review only);
23. ESPC Plan Notes, Sheet 25 of 34 (cursory review);
24. ESPC Plan Details, Sheets 26 through 28 of 34 (cursory review);

25. Post-Construction Stormwater Management (PCSM) Pre-Development Plan, Sheet 29 of 34;
26. PCSM Post-Development Plan, Sheet 30 of 34;
27. PCSM Drainage Areas Plan, Sheet 31 of 34;
28. PCSM Notes, Sheet 32 of 34;
29. PCSM Details, Sheets 33 and 34 of 34;
30. Stormwater Conveyance Narrative Report & Calculations;
31. Stormwater Management Narrative Report & Calculations;
32. Stormwater Ponding Analysis; and
33. Waiver request letter.

In addition, we have received the following information in support of the Application:

1. E&S Module 1;
2. PCSM Module 2;
3. Response Letter to Community Development Department;
4. Response Letter to Landscape and Shade Tree Commission;
5. Response Letter to Parks and Recreation Board;
6. Response Letter to Public Works;
7. Response Letter to Township Utility Engineer;
8. Response Letter to Township Engineer;
9. Response Letter to Township Geotech Engineer;
10. Response Letter to Township Zoning Officer;
11. SALDO Application, dated December 6, 2023; and
12. Transmittal Letter, dated December 7, 2023.

**Spotts, Stevens and McCoy**

Roma Corporate Center, Suite 106

1605 N. Cedar Crest Blvd. &gt; Allentown PA 18104

610.849.9700 &gt; F. 610.621.2001 &gt; SSMGROUP.COM



January 31, 2024

Mr. Gregg Adams, Planner  
South Whitehall Township  
4444 Walbert Avenue  
Allentown PA 18104

Re: Eck Road Outdoor Storage  
Land Development #2022-109  
Review of Preliminary Final Plan  
SSM File 103400.0084

Dear Mr. Adams:

This correspondence is provided as a review of the Preliminary/Final submitted for the above referenced project as revised on January 18, 2024. We offer the following comments on the water and sewer utilities:

Water Comments

1. Sheet 14 of 34: Relocate water service label to be legible. 1" conflicts with profile grid line.
2. Include SWT Std. Detail for 1" Meter box. SWT Std No W-12, as adopted June, 2023.

Sanitary Sewer Comments

None at this time.

Please contact us should you have any questions, or require any additional information regarding our comments.

Sincerely,  
Spotts, Stevens and McCoy

A handwritten signature in blue ink that reads "Jason M. Newhard".

Jason M. Newhard, CCM, LO  
Manager, Construction Management Services  
Environmental Engineering  
[jason.newhard@ssmgroup.com](mailto:jason.newhard@ssmgroup.com)

cc: SWT, PW



June 2, 2023

Martin F. Smith, Jr. P.E.  
Pany & Lentz Engineering Co.  
609 Hamilton St.  
Allentown PA 18101

Re: Eck Road Outdoor Storage  
Land Development #2022-109  
Water Service Request  
SSM File 103400.0083

Dear Mr. Smith:

We are in receipt of your request to South Whitehall Township for the water and sanitary sewer willingness to serve letter for the proposed outdoor truck trailer storage located at 1429 Eck Rd. A copy is attached to this letter for reference. The proposed facility is projected to use 10 gallons per day of water. At this time the water and sanitary sewer systems owned by South Whitehall Township have adequate capacities and will serve the proposed development with water and sanitary sewer. Please be advised, the Township reserves the right to analyze and assess any required increases in allocations based upon actual water usage.

We are providing allocation and tapping fee amounts per S. Whitehall regulations as follows:  
Proposed Avg. water usage on 1 employee at 10 GPD, which is a minimum of 1 EDU water and sanitary sewer.

Basis of EDU for allocation and tapping calculations in accordance with BOA 2013-11:

Water EDU = 154.7 gal/day = 1.0 EDU  
Sewer EDU = 214.2 gal/day = 1.0 EDU

The capacity allocation (reservation) fees are:

Water Allocation = 154.7 gallons x \$3.58/gal = \$553.83  
Sewer Allocation = 214.2 gallons x \$3.58/gal = \$766.84

Per Resolution No. 2016-05-BOA sewer and water tapping fees:

Water Tapping Fee = 1.0 EDU x \$1,885.00= \$1,885.00  
Sewer Tapping Fee = 1.0 EDU x \$4,125.00= \$4,125.00  
Total Allocation and Tapping Fee = \$7,330.67

Please contact our office should you have any questions or comments.

June 2, 2023  
Mr. Martin Smith, Jr., P.E.  
Pany & Lentz Engineering Co.  
Page 2 of 2



Sincerely,  
Spotts, Stevens and McCoy

A handwritten signature in blue ink that reads "Jason M. Newhard".

Jason M. Newhard, CCM, LO  
Manager, Construction Management Services  
Environmental Engineering  
[jason.newhard@ssmgroup.com](mailto:jason.newhard@ssmgroup.com)

cc: SWT, PW



# HanoverEngineering

252 Brodhead Road • Suite 100 • Bethlehem, PA 18017-8944  
 Phone: 610.691.5644 • Fax: 610.691.6968 • HanoverEng.com

January 31, 2024

Mr. Gregg Adams, Planner  
 South Whitehall Township  
 4444 Walbert Avenue  
 Allentown, PA 18104-1699

RE: Geotechnical Engineering Review of  
 Provided Documents  
 1429 Eck Road Outdoor Storage  
 Major Plan 2022-109  
 South Whitehall Township, Lehigh County,  
 Pennsylvania  
 Hanover Project SWT22-11(015)

Dear Mr. Adams:

Hanover Engineering (Hanover) has reviewed the information received on January 18, 2024 via electronic link. Reviewed documents pertaining to the geotechnical aspects of the proposed project at the above-referenced site consisted of the following:

1. Waiver request letter referenced as "Revised SALDO Waiver Request", prepared by Pany & Lentz (P & L), dated January 18, 2024.
2. Engineering plan set entitled "Preliminary/Final Land Development Plans for 1429 Eck Road Outdoor Storage", Sheets 1 of 34 through 17 of 34 (a partial submission), prepared by P & L, dated May 15, 2023, last revised January 18, 2024.

Based on our review, it is our understanding that the subject property consists of a vacant, single tax parcel approximately 5.11 acres in size. The applicant proposes to construct a seventy-eight (78)-space outdoor storage area for trailer storage along with a guard booth, eight (8) car parking spaces, stormwater management facilities, and utility extensions. An area would be reserved for future sixteen (16) car parking spaces. The proposal includes approximately 113,000 square feet of new impervious area on site and an additional 11,000 square feet of impervious area associated with the proposed widening of Eck Road and sidewalk along Eck Road. The site will be served by public water and public sewer. This is a fourth submission of documents to this office for review. We offer the following review of comments issued in our letters of June 6, 2023, October 6, 2023, and December 22, 2023 (repeated below in italics), and any new comments generated by this submission:

A. *Chapter 296, Stormwater Management, of the South Whitehall Township Code:*

1. *Chapter 296-11.J: Normally dry, open top, storage facilities should completely drain both the volume control and rate control capacities over a period of time not less than twenty four (24) hours and not more than seventy-two (72) hours from the end of the design storm. Demonstrate compliance with this requirement.*

*This comment has not been addressed. The consultant states to see the Stormwater Management Report. However, this information is not readily found in that document.*

This comment has been adequately addressed.

2. *Chapter 296-11.T: Within areas containing soils identified by the Soils Conservation Service to be sinkhole prone, detention basins shall be lined with a material which, after installation, attains a permeability rate of less than or equal to  $1 \times 10^{-7}$  cm/sec. On the Basin Section Detail, the applicant has proposed an "impervious liner". Provide specifications for the liner material, thickness, etc. which include the permeability requirement in this section.*

This comment has been adequately addressed.

3. *Chapter 296-11.Y: Infiltration for stormwater management is encouraged where soils and geology permit, consistent with the provisions of this chapter and, where applicable, the Recommendation Chart for Infiltration Stormwater Management BMPs in Carbonate Bedrock in Appendix D. Infiltration is encouraged for capturing and treating the Water Quality Volume, any part of the Water Quality Volume, or for otherwise meeting the purposes of this chapter. The applicant shall demonstrate that this proposal is consistent with the Recommendation Chart.*

*This comment has not been addressed. The consultant states to see the Stormwater Management Report. However, this information is not readily found in that document.*

This comment has been adequately addressed.

4. *Chapter 296-15.K: For infiltration areas that appear feasible based on the preliminary site investigation, the applicant shall conduct the additional site investigation and testing as outlined in Appendix G. The report states that infiltration tests will be conducted in fill placed during construction. This office shall be notified of the testing schedule to allow for observation of the testing.*

This comment has been adequately addressed. The applicant has had testing conducted on the existing site and has provided a report of the results.

## B. Land Development Plans

1. *Section 312.12(b)(18) of the Subdivision and Land Development Ordinance: Provide and label the location of all significant features listed, or provide a note stating which features do not exist on the site.*

This comment has been adequately addressed.

2. *Section 312.39(D)(2) of the Subdivision and Land Development Ordinance:*

- a. *Requires a minimum two percent (2%) slope across the basin floor. The proposed slope is zero percent (0%). The applicant shall provide a design which complies with this requirement or formally request a waiver.*

*This comment has not been addressed. The consultant states that a formal waiver request has been initiated and to see the Waiver Note on the plans. This item does not appear in the Waiver Note and should be added. This item does not appear in the waiver request letter and should be added.*

This comment has been adequately addressed. The waiver request has been added to the Waiver Note on the plans and to the revised waiver request letter. Given the configuration of the basin and the inletting stormwater structures, we have no objection to the granting of this waiver.



- b. *Requires a maximum four-foot (4') horizontal to one foot (1') vertical basin slope side wall. The proposed side wall slope is three to one (3:1). The applicant shall provide a design which complies with this requirement or formally request a waiver.*

*This comment has not been addressed. The consultant states that a formal waiver request has been initiated and to see the Waiver Note on the plans. This item does not appear in the Waiver Note and should be added. This item does appear in the waiver letter. We have no objection to the granting of this waiver.*

The consultant previously stated in the Review #2 response letter that "...this waiver is no longer requested as the basin is to be fenced". The proposed side wall slope is still 3:1. If fencing the basin removes the need for this waiver, then this comment is no longer applicable. If not, we again have no objection to the granting of this waiver.

3. *Clearly depict and label the areas proposed for spray irrigation on the plans.*

*This comment has not been addressed. The consultant states that the plans have been revised. However, this information is not readily found on the Land Development plans. It is noted that this information is depicted on the spray irrigation plans, but it must be shown on the Land Development plans.*

This comment has been adequately addressed.

4. *On Sheet 26, a note refers to a "spray irrigation plan set". This document is not found in this submission and shall be provided.*

This comment has been adequately addressed.

5. *Provide specifications for the preparation of the basin subgrade (compacted, free of large coarse fragments and debris, etc.).*

*This comment has not been addressed. The consultant states that the plans have been revised. However, this information is not readily found for the basin.*

This comment has been adequately addressed.

6. *On Sheet 23, Standard E & SC Plan Note 34 should stipulate notification to South Whitehall Township also in the event of sinkhole discovery.*

This comment has been adequately addressed.

7. *The CTL Report, in Section 10.0, lists preventative measures against sinkholes. These should be added to the plan notes.*

This comment has been adequately addressed.

8. *The CTL Report, in Section 11.0, lists general procedures for sinkhole repair. These should be added to the plan notes, or the project geotechnical consultant should review and approve the existing notes and details on the plans.*

This comment has been adequately addressed.

Mr. Gregg Adams  
Planner

January 31, 2024

New Comments (October 6, 2023)

C. *Aqua Mist Plans*

- 1. *The charts on Sheet I-02 include a maximum rate of irrigation for Zone 1 and Zone 2. Clarify how these rates were calculated, based on the permeability test results obtained.*

This comment has been adequately addressed.

New Comments (December 22, 2023)

D. *Retaining Wall*

- 1. *The plans propose a retaining wall forming the north side of Detention Basin 1. Two (2) stormwater pipe runs are proposed to cross through the wall. Two (2) stormwater structures (ES – B1 and OCS – 1) are proposed to be constructed immediately adjacent to the basin side of the wall. Prior to the issuance of a building permit, the consultant shall provide retaining wall design plans, details, and specifications. The retaining wall design shall specify how the construction of the storm sewer pipe runs and structures will be addressed. Details for each crossing and structure shall be provided. Any special construction considerations for the wall being exposed to ponded water in the basin shall be provided.*

This comment will be considered adequately addressed when acknowledged by the consultant.

We trust that this is the information that you require. Should you have any questions or concerns regarding this information, please do not hesitate to contact our office.

Respectfully,

HANOVER ENGINEERING

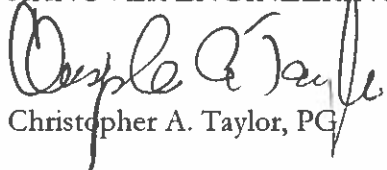

Christopher A. Taylor, PG

cat:cat/sas

S:\Projects\Municipal\WhitehallTownship\Swf22-11 (015)-1429EckRoadOutdoorStorageMajorPlan2022-109\Docs\2024-01-31-SWT Geotech, 1429 Eck Road Outdoor Storage Major Plan geotech cmt ltr 4.doc

- cc: Mr. Dave Manhardt, Director of Community Development (via email)
- Mr. Herb Bender, Public Works Director (via email)
- Mr. Anthony F. Tallarida, PE, The Pidcock Company (via email)
- Mr. Mark Gnall, PE, The Pidcock Company (via email)
- Mr. Joseph Petrucci, Triple Net Investments CI, LLC
- Mr. Stephen A. Pany, PE, Pany & Lentz Engineering Company

December 18, 2023

South Whitehall Township  
4444 Walbert Avenue  
Allentown, PA 18104-1699

Attn: Mr. Gregg Adams

Re: 1429 Eck Road – Outdoor Storage

Dear Mr. Adams:

I have reviewed the Information submitted for the project at 1429 Eck Road in the Township. The following plan was submitted containing the lighting information:

- Sheet LD-8 submitted on May 15,2023 and last revised on December 4, 2023

The plan as submitted does not contain enough information to determine conformance to the latest Township Ordinance, namely:

- (1) There is no manufacturer's cut sheet attached to determine conformance with the latest township ordinance requiring that fixture are full cut-off
- (2) There is no manufacturer's cut sheet or information regarding the poles being used to determine conformance with EPA requirements for wind ratings

Please feel free to contact me if you have any questions.

Very Truly Yours,



Corey Trumbower  
Snyder Hoffman Associates, Inc.

cc: Mark J. Gnall, P.E., Anthony Tallarida, P.E. – The Pidcock Company  
Laura M. Harrier – SWT, Lynn A. LaBarre - SWT

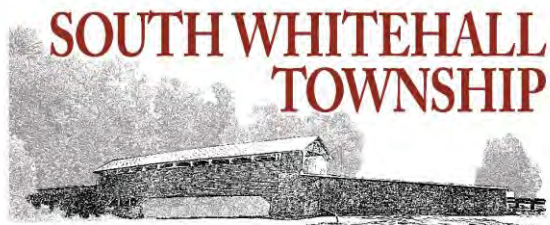

## INTEROFFICE MEMORANDUM

---

**TO: DAVE MANHARDT, DIRECTOR OF COMMUNITY DEVELOPMENT**

**FROM: HERB BENDER, PUBLIC WORKS MANAGER**

**DATE: JANUARY 3, 2024**

**SUBJECT: RIDGE 1429 Eck Rd outdoor storage Major Plan 2022-109**

---

The Public Works Dept. reviewed the above project and has the following comments:

1. Eck Rd. Was recently paved. Please move water service cut to Limit paving disturbance.
2. If paving waver is granted you will follow street excavation ordinance
3. A water meter pit will be required to installed outside of the Right of way

# SOUTH WHITEHALL TOWNSHIP

119

4444 Walbert Avenue, Allentown, PA 18104-1699  
www.southwhitehall.com • (610) 398-0401

February 1, 2024

Triple Net Investments, CI, LLC  
Attn: Joseph Petrucci  
171 Route 173 Suite 201  
Asbury, NJ 08802

**Re: 1429 Eck Road Outdoor Storage  
Major Plan 2022-109  
Request for Preliminary/Final Plan Review**

Dear Mr. Petrucci:

The purpose of this letter is to report zoning and non-engineering related comments that are to be addressed. My comments follow:

## **Zoning**

1. The Zoning Officer's review of the January 18, 2024 plan set has not been received at the time of this writing. The Zoning Officer's January 5, 2024 review comments follow:
  - A. The dumpster location has been replaced by the snow removal device and is listed to be replaced by a trashcan. The trashcan shall be in an enclosed area to prevent trash from leaving the property and it shall be accessible to pedestrians on-site. Show and label where the trashcan is proposed.
  - B. Show and label on the plan the solid fence to be installed near the residential dwelling as stated in Condition "e" of the ZHB approval. Extend the berm and fence to the Eck Rd property line. The fence should be placed on top of the berm to provide maximum screening for the residential use. Show and label on the landscaping plan the type and height of the required fence. Ensure the buffer plantings are located to the North of the fence.
  - C. Chainlink and split-rail fencing are proposed on the plan. Show and label all fencing (type and height) on the plan.
  - D. Show and label on the plan the placement of the berm near the residential dwelling as stated in Condition "g" of the ZHB approval. Extend berm to the Eck Rd property line.

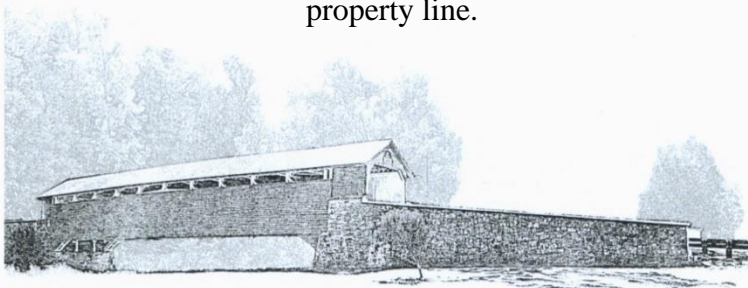

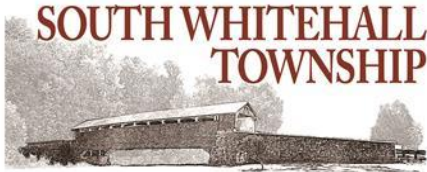

### **Fire Marshal and Public Safety Commission**

1. The Fire Marshal reported no comments to the plan.
2. The Public Safety reviewed the plan at its June 5, 2023 meeting and reported no comments.

### **Landscape and Shade Tree Commission**

1. Staff had determined that all comments have been addressed.

### **Open Space and Recreation**

1. The Parks and Recreation Board recommended that the developer pay fees in lieu of common open space land dedication to meet the open space and recreation requirements of Section 312-36(d)(4) of the Subdivision and Land Development Ordinance. The amount of fees to be paid in lieu of common open space land dedication in non-residential subdivision or land development shall be Twenty-Five Cents (\$0.25) per square foot of additional proposed impervious coverage (post-development impervious surface minus pre-development impervious surface). According to the Zoning Data Block on sheet LD-2, the plan proposes an additional 106,084 square feet of impervious surface, resulting in a fee of \$26,521.00.

### **Water & Sewer**

1. Should connection to the public water and sewer system be proposed, the applicant is to request allocations for water and sewer from the South Whitehall Township Board of Commissioners. Please be aware that the Board of Commissioners now charges both allocation fees and tapping (connection) fees. The applicant must address all water and sewer service issues, and obtain all approvals deemed necessary by the South Whitehall Township Board of Commissioners. You are advised to contact the Township Public Works Manager Herb Bender as soon as practicable, to learn of, or confirm any or all of:
  - a. The amount of any water and/or sewer allocation fees. The application is available on the Township website. The fee for the allocation(s) will be due prior to plan recording;
  - b. The amount of any water and/or sewer connection fees. The fees are due at or before the building permit is to be issued. Application is also available on the Township website.

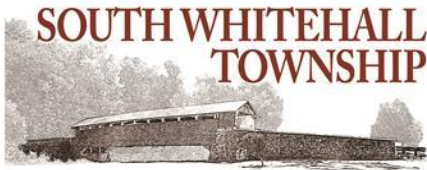

### **Legal and Other**

1. The Township Solicitor and Township Engineer may want to comment upon the legal requirements of the MS4 program with regard to any private stormwater management facilities.
2. The applicant should investigate the sight distance for the proposed crosswalk across Eck Road. Should the investigation determine that there is insufficient sight distance to the south, the applicant should consider moving the crosswalk to a “mid-block” location near or at where the walkway from the parking area joins the currently-proposed sidewalk or to the “intersection” location at the northern entrance of the Crackersport Road DC warehouses. In such case, staff may support a deferral of some or all of the sidewalk along the frontage of Eck Road.

### **Plan Recording Requirements**

1. Prior to plan recording, the applicant shall submit a check set of plans in PDF format to the Township Engineer and Township to ensure that the standards and requirements of the Lehigh County Recorder of Deeds Office for a recorded plan are met.
2. Signature Blocks and Certifications to appear on each plan sheet to be recorded.
3. The size of the plan sheet shall be noted on the upper left-hand corner of every plan sheet to be recorded.
4. Wherever a Parcel ID is shown on a plan sheet to be recorded, it shall include the appropriate parnum suffix, such as 547677593477-1 or 547687003997-59.
5. Wherever an Owner’s signature is required, the Signature shall be accompanied by a Printed Name and Title (Owner or Title within the owning organization), and an area for a Notary stamp. If there are multiple owners, there shall be signature blocks and areas for Notary stamps for each and every owner’s name. The name of the owner (individual and/or organization) in the signature block shall match the name listed elsewhere on the plan.
6. On the cover sheet or (if no cover sheet is present) the site plan sheet, include a table listing all of the properties involved in the project, including PIN and Parnum. This information may be included within an existing table or a new table may be created.
7. The review date of the Planning Commission and the review date and Resolution number of the Board of Commissioners shall be placed into the appropriate Board endorsement notes on the appropriate plan sheet to be recorded. Dates and Resolution number may be obtained from South Whitehall Township.



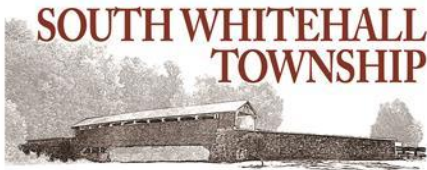

### **Waiver and Deferral Request Commentary**

1. Waiver of Streets and Sidewalks Section 304-27(A) requiring that newly paved street surfaces not be excavated or opened within five years. Staff defers to the Public Works Department.
2. Waiver of SALDO Section 312-12(b)(15) requiring the showing of existing and proposed contours within 400 feet of the tract. Staff defers to the Township Engineer.
3. Waiver of SALDO Section 312-12(b)(21) requiring the showing of existing rights of way within 400 feet of the tract. Staff defers to the township Engineer.
4. Waiver of SALDO Section 312-35(b)(8)(B) requiring grading beyond the right of way to provide continuous slope. Staff defers to the Township Engineer.
5. Waiver of SALDO Section 312-36(c)(5)(A) requiring a driveway width of not more than 40 feet. Staff defers to the Township Engineer.
6. Waiver of SALDO Section 312-39(d)(2) requiring basin side slopes to be less than 4:1 slope. Staff defers to the Township Engineer.
7. Deferral of SALDO Section 312-26(a) requiring the indication on the plan and construction of all required public improvements along Eck Road in front of the Pushkar tract. Staff seeks the improvement of Eck Road, including cartway and curbing at a minimum, within the right-of-way available to the applicant. Such improvements shall tie in smoothly with the proposed improvements along the frontage of 1429 Eck Road and the adjoining Hauser tract. Staff would be willing to support a deferral to the extent that the above goals are achieved.

### **Official Map & Comprehensive Plan**

1. The Official Map depicts the subject parcel as fronted by a Collector Road (Eck Road) and a rail line and underlain by karst geology.
2. The Comprehensive Plan envisions the tract within an Industrial Land Use Type. The goal of Industrial is to:
  - Require buffers to be proportionate to the degree of impact and intensity of development.
  - Consider transit and multimodal connection to support industrial employees.
  - Coordinate development along transportation routes that can appropriately accommodate traffic impacts and require necessary transportation improvements.

Your plan is scheduled to be reviewed by the Planning Commission on Thursday, February 8, 2024 at 7:00 p.m. in the South Whitehall Township Municipal Building located at 4444 Walbert



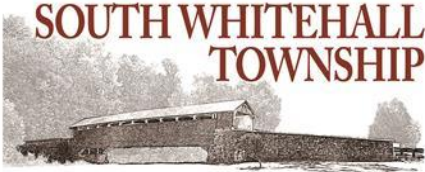

Avenue. The meeting will be also be livestreamed via GoToMeeting. To access the meeting though your computer, go to <https://global.gotomeeting.com/join/757430189>. To access the meeting through your phone, dial 1-224-501-3412 and, when prompted, enter 757 430 189 to join the meeting.

Sincerely,

**Gregg R. Adams, Planner  
Community Development Department**

cc: T. Petrucci            H. Bender            D. Manhardt        L. Harrier            M. Elias            J. Frantz  
    L. Pereira, Esq.        S. Pidcock            A. Tallarida        M. Smith, P&L      File 2022-109

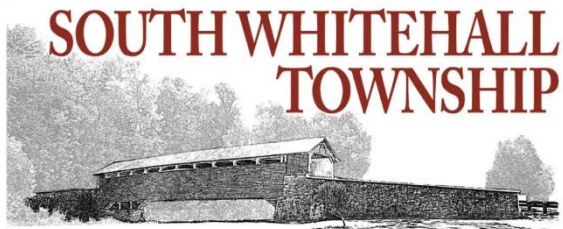

## MEMORANDUM

**TO:** Planning Commission  
**FROM:** Gregg Adams, Planner  
**DATE:** November 16, 2023  
**SUBJECT:** Subdivision Plan Review  
 1429 Eck Road Outdoor Storage  
 Major Plan 2022-109  
 Plan Dated September 25, 2023

**COPIES:** Parks and Recreation Board, T. Petrucci, L. Matula, D. Manhardt,  
 J. Alderfer, S. Pidcock, A. Tallarida, Applicant

At their November 13, 2023 meeting, the Parks and Recreation Board reviewed the plan and determined the following:

The Parks and Recreation Board recommended that the developer pay fees in lieu of common open space land dedication to meet the open space and recreation requirements of Section 312-36(d)(4) of the Subdivision and Land Development Ordinance. The amount of fees to be paid in lieu of common open space land dedication in non-residential subdivision or land development shall be Twenty-Five Cents (\$0.25) per square foot of additional proposed impervious coverage (post-development impervious surface minus pre-development impervious surface). According to the Zoning Data Block on sheet LD-2, the plan proposes an additional 112,811 square feet of impervious surface, resulting in a fee of \$28,202.75.

Respectfully submitted,

Gregg Adams, Planner  
 Community Development Department



# Lehigh Valley Planning Commission

STEVEN GLICKMAN  
Chair **125**

CHRISTOPHER AMATO  
Vice Chair

KEVIN SCHMIDT  
Treasurer

BECKY A. BRADLEY, AICP  
Executive Director

June 16, 2023

Mr. Gregg Adams  
South Whitehall Township Planner  
4444 Walbert Avenue  
Allentown, PA 18104

**Re: 1429 Eck Road Outdoor Trailer Storage – Land Development  
South Whitehall Township  
Lehigh County**

Dear Mr. Adams:

The subject applicant conceptualizes a lot line adjustment and development of an overnight trailer parking lot with guard shack at 1429 Eck Road (Parcel identification number 547720402074).

The LVPC offers the following comments:

### **Tractor-Trailer Accommodations**

The LVPC commends the efforts to strengthen freight infrastructure to minimize quality of life impacts to residents by providing long-term trailer storage (Policy 2.4). A lack of truck parking is a regional concern that can be mitigated by providing opportunities for safe parking by the developers of such warehousing and logistics facilities. These types of buildings rely on trucks to supply and transport goods and services and their needs should be addressed during the development process.

### **Emergency Services**

The LVPC commends the inclusion of snow removal equipment on-site to remove snow from the tops of trailers as required by the Pennsylvania State Snow Removal Law to enable drivers to safely remove snow before departure and eliminate snow and ice shear while traveling on public roads (of Policy 2.2).

The LVPC commends the implementation of emergency vehicle safety measures and feasibility of truck turning maneuvers throughout the proposed development (of Policy 5.1).

### **Development**

A small section of the project site is in a farmland preservation area, although the parcel is within a development area. Development areas have most, or all of the factors needed to support growth, such as transportation infrastructure capacity and contiguity to existing development and are capable of accommodating a substantial amount of



additional development. This is appropriate for major commercial and industrial development.

### **Inclusion of Sidewalks**

The LVPC commends the proposed sidewalks constructed along Eck Road and the entrance of the site. This will 'promote safe and secure community design' (Policy 5.1) and facilitate future connections to the external sidewalk network.

### **Landscaping**

The LVPC commends the applicant for the inclusion of bountiful natural plantings and landscaping features throughout the site design. The use of native, climate-adaptive landscaping that removes carbon dioxide from the air and stores it where it doesn't hurt the environment serves to 'reduce climate change impacts through mitigation and adaptation' (Policy 3.4).

### **Stormwater Review**

The project site is located within the Little Lehigh Creek watershed. This watershed has a fully implemented Act 167 Stormwater Management Ordinance. Comments relative to our review of the project's stormwater management plan are included as attachment 1.

Municipalities, when considering subdivision/land developments, should reasonably attempt to be consistent with *FutureLV: The Regional Plan*, as required by the Pennsylvania Municipalities Planning Code (MPC) [Article I§105, Article III§303, §304 & §306(a), Article VI§603(j)]. The LVPC review does not include an in-depth examination of plans relative to subdivision design standards or ordinance requirements since these items are covered in the municipal review.

Sincerely,



Bambi Griffin Rivera  
Senior Community and Regional Planner

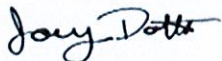

Joseph Dotta  
Community Fellow

cc: Triple Net Investments CI c/o Joseph Petrucci, Applicant;  
Pany & Lentz Engineering c/o Martin Smith, PE, Project Engineer/Surveyor;  
Scott J. Pidcock, Township/Borough Engineer;  
David Manhardt, Director of Community Development;  
Daryl R. and Cheryl L. Long, Record Property Owner



ATTACHMENT 1

Act 167 Drainage Plan Review

June 16, 2023

Re: 1429 Eck Road Outdoor Trailer Storage  
Plans Dated May 15, 2023  
South Whitehall Township  
Lehigh County

The proposed storm drainage concept presented in the plans dated May 15, 2023 and storm drainage calculations dated May 18, 2023 has been reviewed for consistency with the *Little Lehigh Creek Watershed Act 167 Storm Water Management Ordinance*, June 1999. A checklist of the Act 167 review items is attached for your information. As indicated on the checklist, each item of the Drainage Plan has been reviewed for consistency with the Act 167 Ordinance. A brief narrative of the review findings is as follows:

The proposed development is located within drainage district 173 of the Little Lehigh Creek Watershed as delineated in the Act 167 Plan. As such, the runoff control criteria for the site are a 30% Release Rate for the 2-year storm and a 100% Release Rate for the 10-, 25- and 100-year return period storms. Based on review of the plans and calculations, the following deficiencies are noted. The southern third of the site drains to an apparent closed depression. The impact of the closed depression on peak flows to drainage point 1 needs to be evaluated. The pre-development time of concentration path and calculations need to be provided as the assumed 5 minutes appears underestimated. The proposed grading creates a swale along the northern property line that may impact the adjacent property. The 2-year 30% Release Rate is not met, and the design does not control the 2-year runoff volume year-round with the winter orifice activated. Therefore, the Drainage Plan has been found to be inconsistent with the Act 167 requirements.

Note that only those details of the Drainage Plan included on the checklist have been covered by this review. Therefore, notable portions of the Drainage Plan not reviewed include any aspect of the post-construction storm water management plan concerning water quality, the details and design of any proposed water quality BMPs, the Erosion and Sedimentation Control Plan and the details of the runoff collection system (piping). These items are reviewed by the municipal engineer and/or others, as applicable.

Once the outlined issues have been addressed, the revised plans, completed application form and appropriate review fee will need to be resubmitted to our office. Please call with any questions regarding these comments.

Sincerely yours,

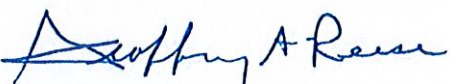

Geoffrey A. Reese, PE  
Master Planner and Engineer



Denjam Khadka  
Senior Civil/Environmental Engineer

Attachment

LVPC ACT 167 REVIEW CHECKLIST

Development Name: 1429 Eck Road Outdoor Trailer Storage  
 Municipality: South Whitehall Township  
 Date: June 16, 2023

Watershed: Little Lehigh Creek  
 Reviewer: Denjam Khadka  
 Checked by: Geoffrey A. Reese, PE

Ordinance Reference	Item	Consistency w/Ordinance		Comment
		Yes	No N/A	

301.A-G. General storm water management requirements ..... X / /  
 H. Consideration of volume controls ..... X / /

302.A,B. Applicable Storm Water Management Provisions

Subarea(s)		
173		
30%/100% RR		

Criteria Key: RR = release rate; CND = conditional no detention

303.A. Design consistency with applicable provisions from 302.A. and B. .... / X /  
 B. Mapping of Storm Water Management District Boundaries..... X / /  
 C. Downstream capacity analysis ..... / / X  
 D. Multiple discharge points within a single subarea ..... / / X  
 E,F. Multiple discharge points within multiple subareas ..... / / X  
 K. Documentation of no increase in peak or volume ..... / / X  
 L. Documentation of "no harm" downstream ..... / / X  
 M. Regional or subregional detention analysis ..... / / X  
 N. Capacity improvements analysis ..... / / X

See Attachment 1 for details.

304.A. Computation method (rational or soil-cover-complex) ..... X / /  
 B. Verification of detention design by routing ..... / X /  
 C. Minimum detention pond freeboard specifications ..... X / /  
 E. Soil-cover-complex method design rainfall ..... X / /  
 F. Rainfall intensities for rational method ..... / / X  
 G. Curve Numbers for soil-cover-complex method ..... X / /  
 H. Runoff coefficients for the rational method ..... / / X  
 I. Volume control storage volume ..... / / X  
 K. Common time of concentration ..... / / X  
 L. Manning equation to calculate watercourse capacity ..... / / X

Soil-cover-complex method used.  
 See Attachment 1 for details.

403. Drainage Plan Contents ..... / X /

See Attachment 1 for details.

**P** ANY  
&  
ENTZ **ENGINEERING COMPANY**

---

**Re: 1429 Eck Road, PIN #5547720402074-1  
South Whitehall Township, Lehigh County  
Preliminary/Final Land Development Plan Submission  
Project Narrative**

May 17, 2023

David Manhardt, AICP  
Director of Community Development  
South Whitehall Township  
4444 Walbert Avenue  
Allentown, PA 18104

Dear Mr. Manhardt:

I am preparing this letter on behalf of Triple Net Investments CI, LLC, the equitable owner of an undeveloped property located at 1429 Eck Road, Allentown. By means of this letter, I am providing the requested project narrative to accompany the Preliminary/Final Land Development Plan submission.

The site is approximately 5.11 acres in size and is located on the east side of Eck Road (T.R. 498) within the IC-1 Industrial Commercial Zoning District and TND – Industrial Retrofit and Infill overlay district. The applicant proposes to construct a 78-space outdoor storage area for trailer storage. Construction will also include an approximately 100 square foot guard booth, 8 car parking spaces, an area reserved for future 16 car parking spaces, stormwater management facilities and utility extensions.

The proposed development includes approximately 113,000 square feet of new impervious area on site and an additional 11,000 SF of impervious associated with the proposed widening of Eck Road and sidewalk along Eck Road. Additional right-of-way will also be dedicated along Eck Road. The site will be served with public water and sewer.

Outdoor Storage is permitted by Special Exception in the IC-1 district. A Special Exception application was made and heard by the South Whitehall Township Zoning Hearing Board at their November 30, 2022 meeting. The ZHB subsequently approved the Special Exception request. As part of the Special Exception request, a variance for relief from the required off-street parking requirements was also granted. This relief will allow for the construction of 8 car parking spaces initially with 16 spaces held in reserve.

Pany & Lentz Engineering Company  
609 Hamilton Street • Allentown, PA 18101  
PHONE: 610/433-1634 • FAX: 610/433-1636

As required by §350-48(o)(9) of the South Whitehall Township Zoning Ordinance, the Outdoor Storage area is to be enclosed by a chain-link fence. The total enclosed area was utilized for the off-street parking calculations noted above. As Outdoor Storage is the use proposed, the setbacks along the property lines apply to the use, that is areas of trailer storage. The proposed plan and layout utilizes allowed reductions in the front yard setback by proposing a sidewalk along Eck Road, planting street trees along Eck Road and connecting the public sidewalk to on-site facilities via a sidewalk.

On behalf of the applicant, we appreciate your consideration of our application.

Please feel free to contact me via email at [mfsmith@plec.us](mailto:mfsmith@plec.us) or phone at 610-433-1634 if there are any questions on the items submitted or additional information required to review this application.

Very truly yours,  
**Pany & Lentz Engineering Co.**

  
Martin F. Smith, Jr., P.E

CC: Triple Net Investments CI, LLC  
Erich Schock, Fitzpatrick, Lentz & Bubba  
Stephen Pany, PE



**P**ANY  
&  
**L**ENTZ **ENGINEERING COMPANY**

---

**Re: 1429 Eck Road Outdoor Storage**  
**PIN #5547720402074-1**  
**South Whitehall Township, Lehigh County**  
**Preliminary/Final Land Development Plan Submission**  
**Revised SALDO Waiver Request**

January 18, 2024

David Manhardt, AICP  
Director of Community Development  
South Whitehall Township  
4444 Walbert Avenue  
Allentown, PA 18104

Dear Mr. Manhardt:

I am preparing this letter on behalf of Triple Net Investments CI, LLC, the equitable owner of an undeveloped property located at 1429 Eck Road, Allentown.

By means of this letter, I am respectfully requesting the following waiver for the above referenced land development plan:

1. **SECTION 304-27(A)** – requesting a waiver from the requirement to not excavate or open a paved and improved street surface less than five years old. The request is made to allow for required road widening, sanitary connection, and water connections including a fire hydrant.
2. **SECTION 312-12(b)(15)** – requesting a waiver from the requirement to show existing and proposed contours within 400 feet of the project site. The request is made to allow the plans to be legible at the scale of 1" = 50'. The plans currently show approximately 200 feet beyond the property line.
3. **SECTION 312-12(b)(21)** – requesting a waiver from the requirement to show existing sidewalks, trails, driveways, streets, extensions, and right-of-way, etc. within 400 feet of the site. The request is made to allow the plans to be legible at the scale of 1" = 50'. The plans currently show approximately 200 feet beyond the property line.

Pany & Lentz Engineering Company  
609 Hamilton Street • Allentown, PA 18101  
PHONE: 610/433-1634 • FAX: 610/433-1636

4. **SECTION 312-35(b)(8)(B)** – requesting a waiver from the requirement to grade beyond the right-of-way line in order to provide a continuous slope. The request is made to allow for the collection of stormwater runoff within the proposed driveway required for volume and rate control.
5. **SECTION 312-36(c)(5)(A)** – requesting a waiver from the requirement limiting driveway width to a maximum width of 40' at the right-of-way line. The request is made to allow for the necessary driveway curb radii to accommodate trucks entering and exiting the site. The combination of a 28' wide drive and 60' curb radii result in a driveway that is 69' wide at the right-of-way line.
6. **SECTION 312-39(d)(2)** – requesting a waiver from the requirement to have the basin minimum longitudinal slope to be two percent. The basin is to have an impervious liner installed which will limit the chance of sinkholes.

By means of this letter, I am respectfully requesting the following deferral for the above referenced land development plan:

1. **SECTION 312-26(a)** – requesting a deferral from the requirement to improve Eck Road in front of Parcel #547720436370-1 to its full width per the Ordinance. The area owned by the Applicant in front of the Parcel is located within the existing Eck Road right-of-way. The Applicant proposes dedicating the area they own in the right-of-way to the Township and installing road improvements within the existing right-of-way. Any further road improvements in front of Parcel #547720436370-1 would occur at such time a land development is proposed on the parcel.

On behalf of the applicant, we appreciate your consideration of this request.

Very truly yours,  
**Pany & Lentz Engineering Co.**

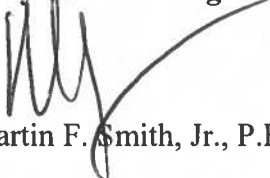
  
Martin F. Smith, Jr., P.E.

CC: Triple Net Investments CI, LLC  
Erich Schock, Fitzpatrick, Lentz & Bubba  
Stephen Pany, PE

Pany & Lentz Engineering Company  
609 Hamilton Street • Allentown, PA 18101  
PHONE: 610/433-1634 • FAX: 610/433-1636



FITZPATRICK  
LENTZ & BUBBA  
ATTORNEYS AT LAW

## MEMORANDUM

TO: South Whitehall Township Planning Commission  
FROM: Erich J. Schock, Esq.  
DATE: January 2, 2024  
RE: 1429 Eck Road Outdoor Storage

---

### BACKGROUND

Triple Net Investments CI, LLC (“Applicant”), is the equitable owner and proposed developer of undeveloped property at 1429 Eck Road. Before the Township are pending land development plans for that use. As part of the most recent submission, Applicant’s engineer included a deferral request from the requirement to make improvements to Eck Road in front of an adjacent parcel. At a prior Planning Commission meeting, Applicant discussed a comment from the Township Engineer relating to what is now the subject of the deferral request.

The subject property contains an anomalous boundary, such that the subject property extends in front of the adjacent property at 1479 Eck Road owned by Michael N. Pushkar III and Mark Pushkar. However, the area in front of the Pushkar property is of insufficient width to allow improvement of the roadway consistent with the improvement to be made along the subject property. The Planning Commission requested that Applicant attempt to acquire additional right of way from the Pushkar property sufficient to construct uniform road improvements.

### ACQUISITION EFFORTS

On November 6, 2023, Joseph Petrucci, on behalf of Applicant, emailed Mr. Pushkar and requested a phone call to discuss Applicant’s possible acquisition of additional right of way. Receiving no response, Mr. Petrucci telephoned Mr. Pushkar at 9 AM on November 8, 2023. Mr. Pushkar indicated that he would prefer to correspond by email. At 9:30 AM on November 8, 2023, Mr. Pushkar emailed questions to Mr. Petrucci, who immediately responded to the questions and again offered an in-person meeting. Since that time Mr. Petrucci followed up by email on three occasions (November 14, November 27 and December 7). Mr. Petrucci received no response from Mr. Pushkar to any of those inquiries. (Applicant will provide copies of the correspondence, if requested.)

**CONCLUSION**

After multiple attempts, Applicant is advising the Township that it is unable by amicable means to acquire any additional right of way along the Pushkar property.