

**SOUTH WHITEHALL TOWNSHIP
SOUTH WHITEHALL
TOWNSHIP AUTHORITY**

LEHIGH COUNTY, PENNSYLVANIA

STANDARD CONSTRUCTION DOCUMENTS

MARCH 2017
ADOPTED APRIL 19, 2017

THE PIDCOCK COMPANY

CIVIL ENGINEERING AND LAND PLANNING ARCHITECTURE LAND SURVEYING

Oxford Drive at Fish Hatchery Road
2451 Parkwood Drive Allentown, Pennsylvania 18103-9608

PREFACE

These Standard Construction Documents are comprised of the General Provisions, Technical Specifications, and Standard Construction Details. The utilization of any portion of these Documents shall consider the content of the full Documents in their entirety.

These Standard Construction Documents are intended to be used for construction and installation of improvements and common amenities (as those items are defined in the Township Subdivision and Land Development Regulations) which are intended to be offered for dedication or otherwise conveyed or transferred to the Township, and to common amenities for which the Subdivision and Land Development Regulations require construction to Township Standards, all pursuant to an approved subdivision/land development plan. It is not intended that these Standard Construction Documents be a substitute for comprehensive project construction specifications as prepared by the Design Engineer for a Developer. These Standard Construction Documents do not address all issues typically addressed in the complete set of plans and specifications by the Design Engineer including but not limited to, safety, management of quantities for payment, waiver of liens, insurance, etc. Additionally, these Standard Construction Documents represent the minimum standards and requirements for construction and installation of improvements and common amenities. In cases where these minimum standards and requirements are not adequate for the specific design, it is incumbent upon and solely the responsibility of the Developer and Design Engineer to identify such inadequacies and provide for the necessary modifications in the design.

These Standard Construction Documents are intended to be used in conjunction with the current edition of the Commonwealth of Pennsylvania, Department of Transportation, Specifications Publication 408, and Bureau of Design, Standards for Roadway Construction. The provisions of the Commonwealth of Pennsylvania, Department of Transportation, Specifications Publication 408, and Standards for Roadway Construction shall govern where applicable, except as specifically modified by the requirements of the Standard Construction Documents.

All work and installations as outlined in these Documents shall be required to comply with all applicable federal, state and local standards and regulations, including but not limited to, Occupational Safety and Health Administration (OSHA) regulations, Department of Labor & Industry regulations, state and local blasting permit requirements, regulations governing earth disturbance, stormwater management, environmental protection, etc.

The Standard Construction Documents prepared by The Pidcock Company are copyrighted. It shall be understood by all parties or persons that this notice of copyright is equivalent to affixing the notice of copyright on every component of the Standard Construction Documents prepared by The Pidcock Company. No other person, party, or organization of whatsoever kind other than The Pidcock Company shall have the legal right to reproduce, publish, or sell any component of the Standard Construction Documents prepared by The Pidcock Company. The Standard Construction Documents are not published, any dissemination or circulation of the Standard Construction Documents notwithstanding, and The Pidcock Company reserves all rights related to the Standard Construction Documents prepared by The Pidcock Company.

CONTENTS

SECTION A GENERAL PROVISIONS	A-1
ART. 1 DEFINITIONS:.....	A-2
ART. 2 RESPONSIBILITY OF THE DEVELOPER:	A-3
ART. 3 RESPONSIBILITY OF THE CONTRACTOR:	A-4
ART. 4 PRECONSTRUCTION REQUIREMENTS:.....	A-4
ART. 5 SCOPE OF OBSERVATION BY THE ENGINEER:	A-5
ART. 6 APPROVALS AND STANDARDS:	A-6
ART. 7 DIFFERING SUBSURFACE AND PHYSICAL CONDITIONS:	A-6
ART. 8 REQUIRED SUBMITTALS:	A-7
ART. 9 SAFETY AND PROTECTION:	A-8
ART. 10 SURVEY:	A-12
ART. 11 MATERIAL TESTING:	A-13
ART. 12 RELEASE OF IMPROVEMENTS SECURITY/COMPLETION OF IMPROVEMENTS:	A-13
ART. 13 RECORD AS-BUILT PLANS:.....	A-13
ART. 14 CERTIFICATIONS:	A-15
ART. 15 WAIVERS:	A-15
ART. 16 CONFLICTS:.....	A-15
SECTION B TECHNICAL SPECIFICATIONS	B-1
STREETS, CURBS AND SIDEWALKS	B-2
STORM SEWERS AND APPURTENANCES	B-13
WATER MAINS AND APPURTENANCES.....	B-24
SANITARY SEWERS AND APPURTENANCES.....	B-37
MISCELLANEOUS IMPROVEMENTS	B-49
SECTION C STANDARD CONSTRUCTION DETAILS	C-1

Section A GENERAL PROVISIONS

GENERAL PROVISIONS

The following GENERAL PROVISIONS are to be used for Work within South Whitehall Township.

Art. 1 DEFINITIONS:

COMMON AMENITIES - Certain additions, alterations, or modifications constructed or made to, upon, or in connection with realty as required by an approved subdivision or approved land development plan and which are not intended to be offered for dedication to the Township or its Authorities.

CONTRACTOR - The term "Contractor" shall in every case be held to mean the individual, co-partnership or corporation performing the Work of the project for the Developer.

DESIGN ENGINEER - The Engineer responsible for preparation of the plans for the Developer.

DEVELOPER - The Developer, where referred to in these Specifications, shall be the individual, partnership, corporation, or other entity, undertaking the improvement of property within the Township pursuant to the Subdivision and Land Development Regulations and/or Zoning Ordinance.

DOCUMENTS - These General Provisions, Technical Specifications and Standard Construction Details for the Township.

ENGINEER - The term "Engineer" shall be held to mean the Township Engineer, acting directly or through duly authorized representatives, such representatives acting within the scope of the particular duties and authority assigned to them by South Whitehall Township and/or South Whitehall Township Authority.

The term "Engineer" may also be held to mean such other person, persons or authority as may hereafter be appointed to succeed to the functions, duties and employment herein specified to be performed by the said Engineer.

GEOTECHNICAL ENGINEER - The Geotechnical Engineer shall be the Geotechnical Engineer advising the Township on geotechnical issues.

HAZARDOUS ENVIRONMENTAL CONDITION - The presence at the site of Asbestos, PCB's, Petroleum, Hazardous Waste, Radioactive Material, Sinkholes, etc.

IMPROVEMENTS - All additions, alterations, or modifications constructed or made to, upon or in connection with realty as required by an approved application and which are intended to be offered for dedication to the Township or its Authorities.

OBSERVER - An authorized representative of the Engineer assigned to make observations of the Work performed or being performed. The Observer is not authorized, and the Contractor shall not rely upon the Observer, to assume any responsibility for the Contractor's means, methods, techniques, sequences, and safety of construction.

PLANS - The plans or drawings of a subdivision or land development as approved by the Township for substantial compliance with the applicable Ordinances, Regulations, etc.

SHOP DRAWINGS - All drawings, diagrams, illustrations, brochures, schedules, and other data which are prepared by the Contractor, a Subcontractor, manufacturer, supplier or distributor, and which illustrates the equipment, material or some portion of the Work.

TOWNSHIP - South Whitehall Township and/or South Whitehall Township Authority.

WORK - Any and all obligations, duties, and responsibilities necessary to the successful completion of the project undertaken by a Contractor which shall include such obligations, duties, and responsibilities not only of the Contractor, but also of each and every Subcontractor.

Art. 2 RESPONSIBILITY OF THE DEVELOPER:

- A. The Developer and its Contractors shall be responsible for compliance with all applicable federal, state, and local laws and ordinances, including but not limited to, Department of Labor & Industry regulations, state and local blasting permit requirements, regulations governing earth disturbance, and other applicable safety codes, etc.;
- B. The Developer shall provide a superintendent or other person responsible for overseeing the Work on a day-to-day basis. In cases where such superintendence is not provided, the Developer or his authorized representative shall meet with the Engineer's representative on a pre-arranged basis to discuss any problems and the general condition of the project;
- C. The Developer shall be responsible to procure all permits, licenses, agreements, easements, etc. and shall be responsible for any and all necessary fees for completion of the Work;

- D. It shall be the responsibility of the Developer anticipating earth disturbance activities on the site of the proposed development to have plans and specifications prepared for soil erosion and sedimentation control. The plans and specifications shall be prepared by a Design Engineer familiar with the requirements of the Department of Environmental Protection (DEP). The plans and specifications shall be prepared pursuant to guidance and procedures provided by all applicable DEP documents. The Developer shall have a copy of the approved plans and specifications available at the site before proceeding with the work; and
- E. It shall be the responsibility of the Developer to complete the Work in accordance with the approved Plans.

Art. 3 RESPONSIBILITY OF THE CONTRACTOR:

- A. The Developer and its Contractors shall be responsible for compliance with all applicable federal, state, and local laws and Ordinances, including but not limited to, Department of Labor & Industry regulations, state and local blasting permit requirements, regulations governing earth disturbance, and other applicable safety codes, etc.;
- B. The Contractor is responsible for notifying all owners of utilities in the Municipality. It is the responsibility of the Contractor to arrange for the field identification, location and protection of all overhead and subsurface utilities--both public and private--which may be encountered during the course of this project; and
- C. The Contractor shall provide a superintendent or other person responsible for overseeing the Work on a day-to-day basis. In cases where such superintendence is not provided, the Contractor or his authorized representative shall meet with the Engineer representative and Township representative on a pre-arranged basis to discuss any problems and the general condition of the project.

Art. 4 PRECONSTRUCTION REQUIREMENTS:

- A. Before any Work at the site can commence, the following must be completed:
 - 1. All necessary Agreements with the Township shall be executed and any required improvements security and/or escrow shall be posted;
 - 2. Satisfactory proof of insurance as required by the Township must be secured by the Developer, approved by the Township Solicitor's office and naming the Engineer as additional insured;
 - 3. The Contractor shall submit to the Township and Engineer a preliminary progress schedule indicating the starting and completion

dates of the various stages of the Work, and a schedule of shop drawing submissions. The Contractor shall provide a minimum of 48 hours notice to the Engineer for observation of work;

4. If, in the opinion of the Township or Engineer, the Work is of such complexity to require a Preconstruction Conference, such a conference will be held to review the above schedules, to establish procedures for handling shop drawings and other submissions, processing improvements security release requests, and to establish a working understanding between the parties as to the project. The conference is to be attended by an authorized representative of the Developer, Contractor, his superintendent, and others as appropriate, and by the Engineer, Geotechnical Engineer, and Township as deemed necessary by the Township. Additionally as Work continues, if in the opinion of the Engineer or Township that job progress meetings are necessary, these meetings are to be attended by the Contractor and Developer; and
5. Copies of all permits and easements necessary to execute the Work must be provided to the Township and Engineer.

Art. 5 SCOPE OF OBSERVATION BY THE ENGINEER:

- A. General observation of the construction of the Work, including but not limited to proposed water, sanitary, and storm sewerage systems, streets, overall grading, traffic signals, etc. shall be performed to the extent deemed necessary by the Engineer given the scope of the Work. Accessory to this observation is the review of all grade sheets, catalog and shop drawing submittals, processing of improvements security release requests, required surveying, etc. The Engineer shall not have the authority to stop the Work; that authority is reserved to the Township and Developer/Contractor;

Any Work done or materials installed without proper notification of the Engineer for observation may be required by the Township to be removed or replaced. Additionally, improvements security for this Work would not be released by the Township;

The Engineer will coordinate with Township staff personnel regarding their observation of the planting of shade trees, buffer strip landscaping, etc.; and

- B. For Work along any State Routes, the Developer and its Contractor shall meet with PENNDOT representatives to identify the scope of PENNDOT construction observation and shall comply with PENNDOT standards for undertaking such work including safety procedures.

Art. 6 APPROVALS AND STANDARDS:

- A. Plans. Should revisions be proposed to the approved plans, revised plans should be submitted promptly to the Township and to the Engineer. Although the plans have been approved by the Township for substantial compliance with the Subdivision and Land Development Regulations, changes may be required due to field conditions which were unknown, or incorrectly or insufficiently described on the drawings. In such instances, it will be the responsibility of the Developer, through the Design Engineer, to propose any changes to the Plans for review by the Township prior to proceeding with the Work. Observers do not have the authority to approve, in the field, any changes from the approved Plans. Any and all requests for deviation from the approved Plans shall be submitted in writing by the Developer to the Engineer and the Township for review and must be accompanied by supporting engineering data. No oral agreements may be substituted for this process;
- B. PENNDOT Publication 408 and PENNDOT Standards for Roadway Construction (latest edition), the Township Subdivision and Land Development Regulations, these Documents, and the Plans and conditions of Plan approval by the Township are the documents which shall apply to Work in the subdivision/land development; and
- C. Although relevant technical portions of these Documents may be relied upon in the specifications prepared by the Developer's engineer for his client, the Professional Engineer's Seal to be put on the specifications and on the Plans shall be that of the Developer's engineer who has the professional responsibility for the complete set of specifications, typically addressing matters of safety, blasting, measurement of quantities for payment, etc. Incorporation of portions or all of these Documents into the project construction documents by the Developer and/or the Developer's engineer constitutes an acceptance of and endorsement of these Documents by the Developer and the Developer's engineer.

Art. 7 DIFFERING SUBSURFACE AND PHYSICAL CONDITIONS:

If the Contractor believes that any subsurface or physical condition at or contiguous to the Site that is uncovered or revealed either differs materially from that shown or indicated in the Plans or is of a hazardous or unusual nature, and differs materially from conditions ordinarily encountered and generally recognized as inherent in Work of the character provided for in the Plans, then the Contractor shall, promptly after becoming aware thereof and before further disturbing the subsurface or physical conditions or performing any Work in connection therewith (except in an emergency) notify the appropriate regulatory agency as determined by the Developer/Contractor, and advise the Township and the Township's Environmental Consultant and/or Geotechnical Engineer in writing about such condition. The Contractor shall not further disturb such condition or perform any Work in

connection therewith (except as aforesaid) until receipt of approval to do so by the Township Environmental Consultant and/or Geotechnical Engineer.

Art. 8 REQUIRED SUBMITTALS:

- A. The Contractor shall review, stamp with its approval on each sheet and submit copies of all material lists, catalog submissions, shop drawings, pipe certifications, concrete and asphalt mix designs, and samples for improvements as proposed by the Plans. All submittals should be properly identified. At the time of submission, the Contractor shall inform the Engineer in writing of any deviation in the submittals from the requirements of the Plans.

Mix design information for all materials used in constructing streets, curbs and sidewalks shall be submitted to and reviewed by the Engineer prior to the delivery of the materials on the project. PENNDOT pre-approval of these mix designs is required. A certification, by type and class, shall be provided to the Engineer to show that all pipe to be used on the project conforms to these Documents.

By approving and submitting shop drawings and samples, the Contractor thereby represents that it has determined and verified all field measurements, field construction criteria, materials, catalog numbers and similar data, or will do so, and that it has checked and coordinated each shop drawing and sample with the requirements of the Work and of the approved Plans.

No portion of the Work requiring a shop drawing or sample submission shall be commenced until the submission has been reviewed by the Engineer or Geotechnical Engineer. All such portions of the Work shall be in accordance with reviewed shop drawings and samples, and no release of security for any improvement will be made until all required documentation has been supplied.

The Engineer's review is only for general conformance with the Township Standards and general compliance with the information given in the Plans. The Contractor is responsible for dimensions to be confirmed and correlated at the job site; for information that pertains solely to the fabrication processes or to the means, methods, techniques, sequences, and procedures of construction; and for coordination of the Work of all trades. Review of catalog submissions or shop drawings by the Engineer in no way relieves the Developer or Contractor from their responsibility to complete all work in accordance with these Documents. Any risk of error or omission or liability resulting thereby is entirely assumed by the Developer and/or Contractor; and

- B. For improvements included in the Work where delegation of professional design services are required by the Plans (e.g., retaining walls, box culverts, etc.) or where the Contractor is proposing an alternative to the Work shown

on the Plans, the Calculations and Shop Drawings or plan revisions submitted must be signed and sealed by the Design Engineer responsible for their preparation. In addition, the Calculations and Shop Drawings or plan revisions submitted must be annotated by the Design Engineer to indicate that they have "Approved" the Calculations and Shop Drawings or plan revisions as being in compliance with the design as shown on the Plans.

Art. 9 SAFETY AND PROTECTION:

- A. Solely the Contractor shall be responsible for initiating, maintaining, and supervising all safety precautions and programs in connection with the Work. The Contractor shall take all necessary precautions for the safety of, and shall provide necessary protection to prevent damage, injury or loss to:
 - 1. All persons on the Site or who may be affected by the Work;
 - 2. All the Work and materials and equipment to be incorporated therein, whether in storage on or off the site; and
 - 3. Other property at the site or adjacent thereto, including trees, shrubs, lawns, walks, pavements, roadways, structures, utilities, and underground facilities not designated for removal, relocation, or replacement in the course of construction.

- B. The Contractor shall comply with all applicable laws and regulations relating to the safety of persons or property, or to the protection of persons or property from damage, injury, or loss; including but not limited to, Occupational Safety and Health Administration (OSHA); Work Zone Traffic Control or 67 PA Code, Chapter 212; e.g., "all workers or persons at the project sites in or alongside the public streets shall wear hard hats and safety vests at all times"; and other applicable safety codes, etc., The Contractor shall erect and maintain all necessary safeguards for such safety and protection. The Contractor shall notify owners of adjacent property and of underground facilities and other utility owners when prosecution of the Work may affect them, and shall cooperate with them in the protection, removal, relocation, and replacement of their property. The Observer does not have the authority to stop the Work because of a safety violation. Nothing in these Documents shall be construed to obligate the Township or the Engineer to enforce the regulations and Standards of the Occupational Safety and Health Administration (OSHA) or other laws and regulations relating to protection of persons or property;

- C. Contractor's duties and responsibilities for safety and for protection of the Work shall continue until such time as all the Work is completed and expiration of the maintenance period;

- D. Maintenance and Pavement Marking and Traffic Signage - The scope of the Work may require the removal or temporary alteration of existing pavement marking and traffic signage. The Contractor shall maintain proper traffic control at all times (day and night) and provide temporary lighting of traffic signage in the event permanent lighting systems are removed or destroyed. The Contractor shall immediately re-establish all pavement markings and traffic signage destroyed, temporarily removed or obscured as a result of the Work.

The Contractor shall maintain traffic and protect the public from all damage to persons and property within the limits of the Work and for the duration of the Contract Period and as a minimum in accordance with the Plans. The Contractor shall furnish and erect all necessary signs, barricades, and bridging, and provide for the adequate lighting of all signs, barricades, and points of special hazard. The Contractor shall be responsible for settling all claims arising from failure on its part to adequately protect vehicular and pedestrian traffic.

The Contractor shall provide temporary bridging and plating in the event the traffic lanes are damaged or altered. Permanent construction of the traffic lanes shall be completed as soon as possible by the Contractor. The Contractor shall provide necessary pavement marking at temporary bridging and plating.

In order to minimize hazard and inconvenience, excavation in driveway and sidewalk areas shall be commenced only after receipt and review by the Engineer of all materials required to complete the particular installation.

No trench shall be allowed to remain partially or totally open overnight without proper signs, barricades, and temporary lighting. Traffic lanes shall be identified, marked, and maintained at all times.

It shall be the duty of the Contractor during the progress of the Work to maintain crossings, walks, sidewalks, and roadways open to traffic in a satisfactory condition, and to keep all fire hydrants, water valves, and fire alarm boxes accessible for use. The Contractor shall continually patrol the project area throughout the construction of the Work to detect the existence of trench subsidence or other conditions resulting from its Work which constitute hazards to the public and it shall immediately remedy all such unsafe conditions. It shall not await notification from the Engineer or the Developer that hazardous conditions exist before acting to correct same.

In the event a road closure and detour is planned, a Detour Plan meeting all applicable requirements related to signs, sign locations, sign durations, etc. must be prepared by a Professional Engineer licensed in the Commonwealth of Pennsylvania, and certified as to compliance with PENNDOT Publication 213, and Federal Highway Manual for Uniform Traffic Control

Devices. The Detour Plan shall be submitted to the Township for review prior to implementation;

- E. The Contractor shall employ the necessary care and safety provisions for trench excavation close to or below the elevation of existing foundations of buildings or other structures, trees, streets, etc. The Contractor alone will be held responsible for any damage to such buildings or their foundation or other structures resulting from its Work.

The Contractor's attention is particularly directed to utility lines which may be in the vicinity of the Work whether or not shown on the Plans. It shall be the responsibility of the Contractor alone to communicate with the owners of such utility lines in advance of performing any Work in the vicinity of said lines and to take precautions adequate to protect said lines from the Contractor's Work which protection shall be the responsibility of the Contractor alone. The Contractor shall be familiar with all federal, state, and local laws and regulations governing excavation and construction, and shall carry out its construction operations in accordance with the provisions thereof;

- F. If the Developer has obtained temporary or permanent construction easements to facilitate the Work in areas outside the public right-of-way, the Contractor is advised that it is to use care to stay within the limits of these easements as indicated on the Plans. The easement limits shall be clearly marked in the field. It is further advised that all reasonable care shall be taken to protect existing features, such as fences, curbs, sidewalks, shrubs, trees, etc., within these easements, and that any damage thereto shall be repaired, or damaged features replaced, at the Contractor's expense alone;
- G. Dust Control - The Contractor shall furnish and apply water and/or other materials, as appropriate and required, and acceptable to all applicable regulatory agencies, for the allaying of dust within the project limits. The dust palliative shall be applied using suitable sprinkler allaying or spreading equipment whenever necessary to prevent dust pollution of the atmosphere;
- H. Caution: When piping systems are pressure tested, it is extremely important and essential that all plugs including test plugs and all pipe joints are installed and restrained in such a way that blowouts are prevented. It must be realized that sudden expulsion of a poorly installed plug or section of pipe or of a test plug which is partially deflated before the pipe pressure is released can be very dangerous. For this reason it is recommended that every plug and pipe joint be positively braced or otherwise restrained during pressure testing and that no one be allowed in a manhole adjoining a line being tested or in the vicinity of an exposed plug or pipe so long as pressure is maintained in the line; and
- I. The following notice shall be posted at the project site at a location accessible to all workers.

NOTICE TO WORKERS

The Pidcock Company (TPC), acting on behalf of South Whitehall Township and the South Whitehall Township Authority (Authority), and South Whitehall Township and the Authority assume no responsibility for or control over the Contractor's safety programs, nor any responsibility for the Contractor's work procedures, methods, sequences, techniques of construction, equipment, etc. Representatives of TPC are at the site only on behalf of South Whitehall Township and the Authority to determine general compliance with applicable Township documents and to determine the acceptability of the final product. Should any worker feel that the work is proceeding in an unsafe manner, it is recommended that the foreman, the project superintendent, the Pennsylvania Department of Labor and Industry, the Occupational Safety and Health Administration, and/or any other regulatory agency having jurisdiction be notified by the worker.

Art. 10 SURVEY:

- A. The Developer shall provide engineering surveys to establish reference points for construction which in the Engineer's judgment are necessary to enable the Contractor to proceed with the Work and to enable the Engineer to confirm its installation in accordance with the Plans. The Developer through its engineer and/or Contractor shall be responsible for laying out the Work, shall protect and preserve the established reference points and property monuments, and shall make no changes or relocations without the prior approval of the Engineer;
- B. All survey and grade control will be the responsibility of the Developer through its engineer and/or Contractor;
- C. Easements for storm drainage facilities and utilities, property lines adjacent to proposed improvements or other locations as may be required by the Township or Engineer, shall be visibly staked prior to construction;
- D. Grade sheets for curbs, waterline, sanitary sewers, storm sewers, swales, etc. shall be submitted for review a minimum of three days before construction. The Developer is responsible for the accuracy thereof;
- E. The Observer will "spot-check" points during construction, as may be necessary. If necessary, the Observer may request the Engineer Survey Department to verify locations. Municipality costs of surveying checks will be treated as an observation charge to the Developer; and
- F. The Developer shall have the basin construction baseline and the controlling site features staked, and shall set grade stakes for the bottom of the basin and the top of berm. Following the Developer's grading operations for the detention basin and prior to placement of the basin liner and topsoil, the Developer's engineer will complete a preliminary basin as-built survey and volume calculations for review by the Engineer to verify that the basin location and volume generally conform to the approved Plans. If applicable, prior to placement of topsoil and seeding, permeability/density testing shall be coordinated with the Geotechnical Engineer and the results of the liner material should be furnished to the Geotechnical Engineer for review with copies to both the Township and Engineer by the Developer to confirm the limiting permeability is achieved, or a certification as to the acceptable installation of the geotextile basin liner shall be provided by the liner manufacturer for Geotechnical Engineer review and approval.

Upon completion of topsoiling and seeding, a final basin survey and volume calculations for review by the Engineer will also be completed by the Developer's engineer to verify that the as-built basin location and volume generally conform to the approved Plans.

Art. 11 MATERIAL TESTING:

All testing shall be as required to satisfy the requirements of the Township Specifications and industry-standard protocols (as appropriate) and shall be in accordance with the applicable specifications.

Art. 12 RELEASE OF IMPROVEMENTS SECURITY/COMPLETION OF IMPROVEMENTS:

Procedures for release of improvements security and the Final and Maintenance Inspections shall be in accordance with the Improvements Agreement with the Township and with Township policies as applicable.

Art. 13 RECORD AS-BUILT PLANS:

Record As-Built Plans shall be prepared by the Design Engineer from information recorded during construction. Information obtained by an Observer is not available for and is not to be used for preparation of the Record As-built Plans. Such plans shall be submitted to the Township and Engineer upon the completion of construction. Following are the record as-built plans submission and drawing requirements:

- A. Submission Requirements: The Developer shall have its Design Engineer prepare, sign and seal, and provide three prints and three copies in electronic format (i.e., .pdf format) for inclusion in the Township Master Plans of the final record as-built plan, drawn in a neat and legible manner, and identified as "Record As-built Plans". The plan preparer and date should be identified. Prior to submitting these plans, one print of the plan(s) shall be submitted to the Township and Engineer for review; and
- B. Drawing Requirements: All construction changes shall be noted by drawing a line through the design data and adding the record data adjacent thereto, or in cases where the plan would be unclear, redrawing the plan to reflect the actual installation. The following specific information shall also be noted:
 - 1. Roads: "Record" curb and/or pavement grades for intersections. Any significant deviations in the centerline profile shall be noted on the plan;

2. Storm Sewerage System:
 - a. Pipe systems (Including underground detention facilities): Invert and top elevations at all manholes, basin outlet control structures, inlets, water quality outlet snouts, endwalls, and sewer lengths, slopes, pipe diameters, types of pipe, and spray-irrigation systems; and
 - b. Detention/Retention Basins: Outlet control structures (orifices, weirs, etc.), riprap aprons or other energy dissipation structures (widths, lengths, type/size or material), low flow channels, emergency spillways (width, elevation, etc.), top of berm elevations, underdrains.
3. Water Distribution System: Stationing of each gate valve, bend, tee, cross, plug, and lateral. Each curb stop and valve box shall be stationed and defined with reference ties when necessary. The location and depth of the water main with respect to the street centerline or utility easement line shall be shown and dimensioned;
4. Sanitary Sewerage System: Invert and top elevation at all manholes, depth, length, and station of each lateral. In the case of skewed laterals, additional reference ties shall be provided. Stationing shall be based on the commonly accepted nearest downstream manhole base slab;
5. Traffic Improvements: Signal equipment, pull boxes, conduits, loops, signs, striping and other pavement markings, depressed curbs, curb ramps, street light poles, etc. shall be noted on the plan;
6. Other Underground Utilities: Location and depth of water, sanitary sewerage system, electric, telephone, cable TV, and gas lines, including wiring between street light poles and transformer where power is supplied within the rights-of-way. Any fiber optic lines should be specifically noted. Any encasement of the above utilities should be identified and the utility location and depth should be shown;
7. Abandoned utilities should be identified by a note and by drawing a line through the original location data;
8. Landscaping: Location, species, and sizes of trees and shrubs;
9. Site Lighting: Location and type of light fixture and height of light standards and buildings mounted lights;
10. Abandoned facilities should be identified by a note and by drawing a line through the original location data; and

11. All BMPs shall be located on the plan and referenced with latitude and longitude.

Art. 14 CERTIFICATIONS:

Certifications shall be provided by the Design Engineer or other appropriate professional (signed and sealed) for monumentation and property pins, and post construction stormwater management (PCSM) BMPs which document that each item has been installed in accordance with the approved Plan. Provide signed and sealed documentation of approval for each critical phase of BMP implementation. Provide documentation from LCCD which indicates their acceptance of the PCSM BMPs and site stabilization. Provide additional copies of the preceding documents to the South Whitehall Township Public Works Department.

Art. 15 WAIVERS:

The Developer or Contractor, as the case may be, may submit a request for a waiver of the requirements of these documents. Such request shall be in writing and shall include evidence that the requirement is unnecessary given the nature of the work or the operation thereof or that the proposed alternative is equal to or greater than the requirements of these documents. The waiver shall be subject to the review and approval of the Board of Commissioners which may replace reasonable conditions on any such approval.

Art. 16 CONFLICTS:

Unless a specific detail or specification is approved by the Board of Commissioners as part of the plan review process, these documents shall apply to the construction and installation of all improvements. In the event of such conflict, the specific detail or specification approved by the Board of Commissioners shall control over the specific requirements of these documents.

Section B TECHNICAL SPECIFICATIONS

SOUTH WHITEHALL TOWNSHIP

TECHNICAL SPECIFICATIONS

STREETS, CURBS AND SIDEWALKS

Materials and Construction

All materials and construction methods used in the construction of streets, curbs, and sidewalks shall meet the requirements as set forth in Pennsylvania Department of Transportation (PENNDOT) Specifications, Publication 408 except as specifically modified by the requirements herein and except that the use of any type of slag, lightweight aggregate, or crushed concrete material is prohibited.

EXCAVATION:

It is required that the Developer maintain all areas in a well-drained condition during the construction period so as to avoid pooling or ponding of water. If a sinkhole should develop during construction, the Developer shall immediately repair the sinkhole at its expense alone and in accordance with the following:

Upon detection of a sinkhole, the Developer or its Contractor shall notify the Township, contact its own geotechnical engineer who shall propose a repair solution and have that procedure reviewed by the Geotechnical Engineer. The Developer's geotechnical engineer and the Geotechnical Engineer shall monitor the repair in accordance with the reviewed procedure and upon completion of the repair and before any construction activity resumes in the area, the Developer's geotechnical engineer shall send a written report to the Township and to the Geotechnical Engineer that the sinkhole has been repaired in accordance with the reviewed procedure and that construction activities may continue.

Undercutting. Rock, shale, hardpan, loose rock, boulders, or other material unsatisfactory for lawns, fields, subgrades, roads, shoulders, or any areas intended for turf shall be excavated to a minimum depth of 12 inches, or to the depth below subgrade as specified by the Developer and its geotechnical engineer and acceptable to the Geotechnical Engineer. Muck, peat, matted roots, or other yielding material, unsatisfactory for subgrade foundation, shall be removed to the depth designated by the Geotechnical Engineer. The excavated area shall be refilled with suitable material, obtained from the grading operations or borrow areas and thoroughly compacted by rolling. Where rock cuts are made and refilled with select material, any pockets created in the rock surface shall be provided with proper drainage.

Compaction Requirements. In cut areas, the upper six inches of the subgrade material under areas to be paved shall be compacted to a density of not less than 95% of maximum density for cohesive soils or 100% of maximum density for non-cohesive soils of the Standard Proctor Density (AASHTO T 99 - Method C).

In cut areas, the upper six inches of the subgrade material under areas to be turfed shall be compacted to a density of not less than 90% of maximum density for cohesive soils or 95% of the maximum density for non-cohesive soils of the Standard Proctor Density (AASHTO T 99 - Method C).

When deemed necessary by the Geotechnical Engineer, the Geotechnical Engineer will determine in-place field density in accordance with AASHTO T 191, Sand Cone Method, or AASHTO T 310, Nuclear Method.

Blasting. Blasting may be permitted only when proper precautions are taken for the safety of all persons, the work, and the property. All damage done to the work or property shall be repaired at the Developer's expense. All operations of the Contractor in connection with the transportation, storage, and use of explosives shall conform to all federal, state and local regulations, instructions from the manufacturer of the explosives, with applicable approved permits to be submitted to the authority having jurisdiction for review. Any review given, however, will not relieve the Contractor of its responsibility in blasting operations.

Blasting shall be performed only after obtaining all necessary permits from state and local agencies and the Township Fire Inspector, as applicable, and notifying the Township prior to each day of blasting.

PREPARATION OF EMBANKMENT AREA. Where an embankment is to be constructed, all sod, vegetative and deleterious matter shall be removed from the surface upon which the embankment is to be placed, and the cleared surface shall be broken up by plowing or scarifying to a minimum depth of six inches. This area shall then be compacted as indicated in Formation of Embankments. Where embankments are to be placed on natural slopes steeper than 3 to 1, horizontal benches shall be constructed.

FORMATION OF EMBANKMENTS. Embankments shall be formed in successive horizontal layers of not more than eight inches in loose depth for the full width of the cross section, unless otherwise specified by the Developer and its geotechnical engineer and acceptable to the Geotechnical Engineer. The grading operations shall be conducted, and the various soil strata shall be placed, to produce a soil structure as shown on the typical cross section or as directed. Materials such as brush, hedge, roots, stumps, grass or other organic matter shall not be incorporated or buried in the embankment.

Operations on earthwork shall be suspended at any time when satisfactory results cannot be obtained because of rain, freezing, or other unsatisfactory conditions in the field. The Contractor shall drag, blade, or slope the embankment to provide proper surface drainage.

Embankment material under areas to be paved shall be compacted to a density of 95% of the maximum dry density per Standard Proctor Density (AASHTO T 99 – Method C) for the entire depth for cohesive soils. Embankment material shall be compacted to a density of 100% of the maximum dry density per Standard Proctor Density (AASHTO T 99 – Method C) for the entire depth for non-cohesive soils.

The in-place field density shall be determined by the Geotechnical Engineer in accordance with AASHTO T 191, Sand Cone Method, or AASHTO T 310, Nuclear Method if considered necessary.

No layer in an embankment area shall be covered by another until the proper density is obtained.

During construction of the embankment, the Contractor shall route its equipment whenever practical, both when loaded and when empty, over the layers as they are placed and shall distribute the travel evenly over the entire width of the embankment. The equipment shall be operated in such a manner that hardpan, cemented gravel, clay, or other chunky soil material will be broken up into small particles and become incorporated with the other material in the layer.

When the excavated material to be used in the embankment consists predominantly of rock fragments of such size that the material cannot be placed in layers of the prescribed thickness without crushing, pulverizing or further breaking down the pieces, such material may be placed in the embankment in layers not exceeding two feet in thickness. Each layer shall be leveled and smoothed with suitable leveling equipment and by distribution of spalls and finer fragments of rock. This type of lift shall not be constructed above an elevation four feet below the finished subgrade. Density requirements will not apply to portions of embankments constructed of materials which cannot be tested in accordance with specified methods. Methods based on performance criteria established from test sections shall be used where the fill gradation does not accommodate traditional in-place density measurements. These procedures establish a performance criteria with test strips consisting of lifts of fill placed in various thickness and number of passes with the compaction equipment. The Developer's engineer shall establish acceptable placement and compaction criteria based on the test strips, as reviewed by the Township.

FINISHING AND PROTECTION OF SUBGRADE. After the subgrade has been substantially completed, the full width shall be conditioned by removing any soft or other unstable material which will not compact properly. The resulting areas and all other low areas, holes or depressions shall be brought to grade with suitable select materials. Scarifying, blading, rolling and other operations shall be performed to provide a thoroughly compacted subgrade shaped to the lines and grades shown on the Plans.

Grading of the subgrade shall be performed so that it will drain readily. The Contractor shall take all precautions necessary to protect the subgrade from damage. Hauling over the finished subgrade is prohibited. All ruts or rough places that develop in a completed subgrade shall be smoothed and re-compacted.

No subbase, base, or surface course shall be placed on the subgrade until the subgrade has been proof rolled with a fully loaded tri-axle dump truck (supplied by the Developer) and reviewed by the Engineer and/or the Geotechnical Engineer, as applicable.

BITUMINOUS CONCRETE PAVEMENT

The following sections of PENNDOT Specifications, Publication 408 shall apply:

Section 409, Superpave Asphalt Mixture Design, Hot Mixed Asphalt (HMA), including the following:

<u>Material</u>	<u>Section</u>
Excavation	203, 204, and 205
Embankment	206
Subgrade	210
Subbase	350
Superpave Asphalt Mixture Design, HMA Base Course (Standard)	309
Superpave Asphalt Mixture Design, HMA Wearing Course (Standard)	409
Plain Cement Concrete Curb	630
Cement Concrete Sidewalk	676

The following procedure will govern the placement of bituminous concrete pavement on streets and/or roads within the Township:

1. Backfilling of utility trenches (such as for sanitary and storm sewers, water mains, gas mains, electrical facilities, etc.) shall be accomplished in accordance with these specifications, unless otherwise specified by the owner of the utility and reviewed by the Township. All trenches and excavations shall be backfilled promptly after the utilities are installed. Method of backfilling shall be as follows:
 - a. Within State Highway Right-of-Way: Backfilling shall be done in accordance with requirements of the State Highway Occupancy Permit;
 - b. Within existing streets the backfill shall consist of:
 - (1) A proper bedding of granular material properly formed to fully support the entire length of pipe;
 - (2) PENNDOT No. 2A stone for initial backfill of sides and top of the pipe to eight inches below the existing subgrade;
 - (3) Where required by the Geotechnical Engineer/Township, eight inches of clay placed and compacted to seal the trench at the subgrade elevation;
 - (4) In lieu of 2. and 3. above and with written approval from the Township, "flowable fill"; i.e., "Controlled Low Strength Material" (CLSM), with late-age strength of 80 to 100 psi may be placed to existing subgrade elevation. The 120-day settlement period (as referenced below) is replaced by the time required to reach late-age strength;

- (5) New base and surface courses to the depths shown on the Standard Construction Details or equivalent to the material of the existing roadway (whichever is greater), as determined by the Engineer; and
 - (6) When excavation of an existing Township street is necessary, it shall be done in accordance with requirements of the Township; i.e., the Street Excavation and Occupancy Permit.
- c. Within proposed streets the backfill shall consist of:
- (1) A proper bedding of granular material properly formed to fully support the entire length of pipe;
 - (2) Clean clay-like material or PENNDOT No. 2A stone for initial backfill of the sides and for 12 inches above the pipe. For HDPE and PVC pipe, only PENNDOT No. 2A stone shall be used to 12 inches above the pipe, which envelope shall be maintained throughout the construction period and shall not extend into subbase materials for roadways;
 - (3) Approved material free from organic matter, large or frozen lumps or stones over ten inches in their largest dimensions. Stones which are used in backfilling shall be so distributed through the mass that all interstices are filled with fine material.

The material shall be moistened or dried, if necessary, to obtain the required compaction. Backfill material shall be reviewed by the Engineer. The use of slag, lightweight aggregate, or crushed concrete in any form for bedding or backfill is prohibited. Special care shall be taken in placing the backfill. Particular care shall be used to obtain thorough compaction under the haunches and along the sides to the top of the pipe.

All backfill shall be placed in loose layers not exceeding six inches in depth under and around the pipe, and not exceeding eight inch lifts over the pipe. Successive layers shall be added and thoroughly compacted by mechanical and pneumatic tampers until the trench is completely filled to the elevation as directed. Backfilling shall be done in such a manner as to avoid injurious top or side pressures on the pipe.

Underground warning tape shall be installed a minimum of two feet above any pipe in the backfill of any mainline or lateral trench. Tape shall be alkali resistant, 4 mils polyethylene, 4 inches minimum width, continuously printed with name or symbol of utility buried below, color coded as follows:

Red: Electric.

Yellow: Gas, oil, and dangerous materials.

Orange: Telephone, cable TV, and other communications.

Blue: Water systems.

Green: Sewerage systems.

Where plastic water or sewer pipe is used the tape shall be appropriately colored and able to conduct a signal generated by a locating device.

Backfill shall be compacted to a density of not less than 95% of maximum density for cohesive soils or 100% of maximum density for non-cohesive soils. The maximum density is the maximum dry weight density in pounds per cubic foot as determined by the Standard Proctor Density (AASHTO T 99 - Method C).

All backfilled trenches shall be allowed to settle for at least 120 days before the permanent base course or pavement may be constructed. Where less than 120 days of settlement time is anticipated and permitted by the Engineer, all trench backfill shall be PENNDOT No. 2A stone, compacted and when required by the Geotechnical Engineer/Township, capped with eight inches of clay at subgrade elevation, wherever permanent base course and pavement is to be constructed. In such cases, the delay time until paving is permitted is to be determined by the Engineer/Township.

2. Weather Limitations.

- a. Bituminous Base Course -- Superpave HMA. Bituminous base course shall not be placed on surfaces that are wet or at a temperature of 35 degrees F or lower, or when the air temperature is 35 degrees F or lower.
- b. Bituminous Wearing Course -- Superpave HMA. Placement shall be permitted during the period 1 April to 15 October annually, provided temperature conditions as listed in (c) below are met and provided further that no paving will be permitted during inclement weather.

Prior to the placement of the wearing course, if the base course is dirty or has set longer than two weeks, the base course shall be satisfactorily cleaned and tacked. The Engineer/Township shall make the above determination when the wearing course is not immediately placed on the base course.

When the bituminous wearing course is placed adjacent to curbs to form a bituminous gutter, it shall be sealed with Koch 9005 rubberized asphalt. Excess bituminous material shall be removed to the satisfaction of the Engineer/Township.

- c. Bituminous Wearing Course -- Superpave HMA. Placement may be permitted during the period 16 October to 15 November under the following conditions:
 - (1) Bituminous wearing course shall be hauled in properly covered and insulated trucks;
 - (2) Bituminous wearing course shall not be placed on damp or wet surfaces;

- (3) Bituminous wearing course shall not be placed when the air temperature is 40 degrees F or lower, nor when the temperature of the base or binder on which it is to be placed is 40 degrees F or lower;
- (4) Extra precautions shall be taken in drying the aggregate to be used in the mix, controlling the temperature of the delivered material, and compacting the mixture;
- (5) Bituminous wearing course shall not be placed if, on the date preceding placement, it rained or snowed and the temperature fell below freezing during the previous evening; and
- (6) Bituminous wearing course shall not be placed after November 15 without a written request from the Developer and the subsequent express written consent of the Township Manager and Engineer.

CONCRETE CURB, SIDEWALK, DRIVEWAY APRONS, AND CURB RAMPS: Construction of plain cement concrete curb shall meet the requirements of Section 630 - Plain Cement Concrete Curb, PENNDOT Specifications, Publication 408. This shall include the placement of concrete curb with an acceptable, self-propelled machine (slip-form machine).

Construction of cement concrete sidewalks, driveway aprons, and curb ramps shall meet the requirements of Section 676 - Cement Concrete Sidewalks, PENNDOT Specifications, Publication 408. Refer to Standard Construction Details - RESIDENTIAL SIDEWALK AND DRIVEWAY APRON - SWT-R-3; NON-RESIDENTIAL SIDEWALK AND DRIVEWAY APRON - SWT-R-4; CONCRETE CURB - SWT-R-5. Refer to PENNDOT Publication #72M. RC-67M for curb ramp construction details. The detectable warning surface material and color shall be reviewed by the Township.

The concrete curb shall be cast to a regular vertical and horizontal alignment. Transition in the vertical and horizontal alignment shall be smooth and continuous. The finish on the visible portion of the curb shall be dense and consistent in appearance. Visible differences in the finish alone shall be grounds for rejection of the curb construction.

Concrete curb, sidewalk, driveway aprons, and curb ramps shall not be placed or cured when the air temperature is or is anticipated to be 40 degrees F or lower without a written request from the Developer and the subsequent express written consent of the Township Manager and Engineer. Concrete curb, sidewalk and driveway aprons shall not be placed on frozen base, subbase or subgrade. Concrete to be used shall be PENNDOT Class AA minimum (minimum mix design 28 day compressive strength of 3,750 psi).

The Contractor shall be particularly diligent in its craftsmanship at expansion and contraction joints and stormwater inlets or any other structure that interrupts the continuity of the concrete curb. Failure to integrate joints and inlets into a consistent and continuous vertical and horizontal alignment and smooth finish shall be grounds for rejection of the curb construction.

BELGIAN BLOCK GRANITE CURB: When permitted by the Township, Belgian Block granite curb shall be installed in accordance with the Standard Construction Details – BELGIAN BLOCK GRANITE CURB – SWT-R-7.

SHOULDERS: Where applicable, the shoulder shall consist of the same pavement structure as the cartway.

UNDERDRAIN: Pipe underdrain shall meet the requirements of PENNDOT Specifications, Publication 408, Section 610 and be reviewed by the Engineer. Inside diameter of pipe shall be six inches, unless otherwise shown on the approved plans.

NOTIFICATION: No connections shall be made to existing Township streets without prior approval and without three working days advance notice to the Township to allow for scheduling of Township observation personnel.

TRAFFIC SIGNAL EQUIPMENT: The Developer and its Contractor shall follow all applicable signalization system design and installation standards and codes including but not limited to standards and codes of IEEE, ASTM, ANSI, International Municipal Signal Association (IMSA), Institute of Traffic Engineers (ITE), and PENNDOT, and shall bear the label of approval of the National Board of Fire Underwriters and Laboratory where applicable. New, first-quality, PENNDOT approved materials, made by a manufacturer of established recognized reputation, shall be furnished and used unless otherwise specified. The Contractor shall follow PENNDOT Publication 408, Sections 930-936, 950-957, 960-966, 1101, 1103, and 1104, as well as Title 67 Chapter 221, Publication 148 (TC-8800), Publication 149, Publication 212, Publication 236, and Publication 111 (TC-8600 and 8700).

A signal corridor analysis shall be provided for any proposed traffic signal within the limits of an existing coordinated corridor or if timing changes are proposed to a traffic signal within the limits of an existing coordinated corridor.

Unless otherwise directed by the Township, all existing equipment to be removed (signs, signal heads, mastarms, controller cabinets, and all hardware within the cabinet) shall remain the property of the Township and shall be inventoried and stored at the location designated by the Township. The Township reserves the right to require the Contractor to legally dispose of any equipment not desired by the Township.

Prior to final acceptance, as-built drawings shall be provided to the Township for review. A copy of the as-built drawing shall be provided for storage in the controller cabinet.

Controllers. All Traffic Signal Controllers shall be the 820A Series, as manufactured by Multisonics and shall be capable of integration into a Closed Loop System. The Controller shall include a hand-held cord in the police compartment, an EDI NEMA 12-channel conflict monitor, a PDC Model SSF-96.3 Solid State Flasher, PDC Model SSS-86 Solid State Load Switches in an EDC Large Single Door Enclosure for NEMA 3R application with a front door compartment and sufficient shelving for the necessary equipment. All Controller Cabinets shall be sized for future Fiber-Optic Telemetry equipment. Emergency Pre-Emption equipment shall be provided for each approach of the intersection and shall be as manufactured by Opticom Infrared System, as follows:

- Opticom Card Rack Model 760
- Opticom Phase Selector Model 464 and Accessories, including Auxiliary Interface Panel, Daughter Board, and/or Adapter Card
- Opticom Detector Model 711
- Opticom Detector Cable Model 138

Location of the pre-emption Detector shall be per the PENNDOT-approved plan or as required to provide sufficient advance detection by approaching emergency vehicles. Additional equipment (repeater, advance detection, link from adjacent intersection, etc.) as may be required to provide sufficient advance detection is to be provided, especially at closely spaced intersections, or where horizontal and/or vertical geometry impedes detection from the local intersection.

Interconnect, if any is required, shall be Fiber Optic cable, 6 fiber 62.5/125 micron multimode, terminated in patch panels with ST connectors. In situations where attachment to utility poles is not available or where conduit and trenching is not feasible, interconnect shall be accomplished with radio, provided a site survey has been performed and the testing substantiates reliability. The approval to proceed with a radio interconnect option shall be at the sole discretion of the Township. A copy of the closed loop software shall be supplied to the Township, if applicable.

All controllers shall be equipped with a battery back-up unit that will automatically switch to battery power unit when the incoming power is interrupted. The controller cabinet must have a 1" red LED indicator which must illuminate when utility power is lost. The controller cabinet shall be equipped with a generator hook-up connection in a separate cabinet.

Signal Support. All Traffic Signals shall be supported with Valmont SMA42X Series of Traffic Signal Mastarms or equal, capable of having an extension to the shaft, and having a luminaire mounting arm added at a future date. Certification by a Pennsylvania Registered Professional Engineer shall be provided indicating that all components at the vertical poles and mastarms are designed by the manufacturer to adequately support the loads shown on the plans or the maximum load requirements established by AASHTO specifications for Structural Supports for Highway Signs, Luminaires, and Traffic Signals, latest edition, whichever is greater. Copies of the PENNDOT Certifications for the signal supports shall be supplied to the Engineer. Design calculations shall be provided to the Engineer for review before fabrication of all non-PENNDOT standard poles. Wire mesh shall be provided between the top of the foundation and the bottom of the base plate to prevent rodent access but permit adequate drainage in place of mortar. For foundations in fill, the required foundation depth shall be measured from the point of minimum grade at the foundation. For foundations in cut, slope protection walls, connected to the top of the foundation, shall be provided. Slope protection wall designs prepared by a Pennsylvania Registered Professional Engineer shall be submitted to the Engineer for review prior to construction. Abandoned Signal Foundations shall be removed to a depth of 1' below final grade, and the existing ground shall be restored in the area of the foundation to provide a uniform level surface. The area disturbed by removal shall be restored to match the adjoining undisturbed area.

Signal Heads. All Vehicular and Pedestrian Signal Head indications shall contain the following Dialight modules:

8" Red: 433-1110-003	12" Green: 433-2220-001
8" Yellow: 433-3130-901	12" Red Arrow: 432-1314-001
8" Green: 433-2120-001	12" Yellow Arrow: 431-3334-901
12" Red: 433-1210-003	12" Green Arrow: 432-2324-001
12" Yellow: 433-3230-901	

The pedestrian signal heads shall have Portland Orange and Lunar White LED indications representing the 'Hand' and 'Walking Person', respectively, manufactured by an approved PENNDOT supplier. All vehicular and pedestrian signal improvements shall be contained in a polycarbonate housing manufactured by PEEK traffic. Back plates, visors, and louvers shall be provided as indicated on the permit plans. Signal heads shall be securely mounted, using signal mounting brackets, where indicated, and in accordance with the regulations. Signal heads shall be installed over roadways with the top of the housings at the same elevation. Where vehicular and pedestrian signals are to be installed on the same support, the assemblies should be separated. Vehicular signal heads shall be aimed, as directed, toward a point approximately 150 feet in advance of the stop line and in the center of the traveled traffic approach. Pedestrian signals shall be aimed to the far side of the crosswalk they are to control. Signals shall be hooded securely with burlap material until the signal is put into operation.

Electrical Distribution. The Contractor shall coordinate with the local power company to obtain metered power for each traffic signal controller cabinet. All meter equipment shall be housed in the Small Single Door Enclosure.

Conduit runs shall be sized for future use. All conduit street crossings will be 3" conduit. Controllers should be located at the intersection of conduit runs, and not at the end of a conduit loop. Each controller foundation or pole foundation (if the controller is pole mounted), will have the equivalent of two 3" conduits entering it from an adjacent junction box. Multiple conduit runs between common terminals shall be installed in a common trench. All effort shall be made to install conduits prior to construction of final grade (i.e., sidewalk, driveways, road widening, et al.). All loops will terminate in junction boxes, and there will be at least one junction box on each corner.

Detection. Detector Lead-In cable shall be IMSA Spec No. 50-2, 14 AWG. Detector Loop wires shall be IMSA Spec. No. 51-5, 14 AWG. Loop Amplifiers shall be Single Channel Digital Inductive Loop Vehicle Detectors.

SIGNS: All signalized intersections shall be signed with Street Name signs of the size and designation as required by PENNDOT. All overhead street name signs (Series D3-4 and D3-5) shall include stiffeners. All stand-alone traffic signs shall be mounted on PENNDOT Breakaway Type 'B' posts.

For sign removal, the identified sign shall be removed from the current location. All sub-surface equipment shall be removed to a depth of 1' below grade and the existing ground in the

area of the sign shall be restored to provide a uniform level surface. The area disturbed by removal shall be returned to match the adjoining undisturbed area. All existing aluminum and steel removed shall be inventoried and stored at the location designated by the Township. The Contractor shall exercise care during removal, storage, bundling, and delivery to prevent additional damage or deterioration of the sign materials, particularly aluminum sign blanks.

For sign relocations, signs shall be removed per sign removal above. The sign shall be installed in the new location, as identified on the plans, or as directed by the Engineer. The Contractor shall provide any anchoring equipment necessary to provide anchoring as originally installed. The Contractor shall be responsible for replacing in kind all signs or posts damaged during removal or reinstallation.

PAVEMENT MARKINGS: Long lane line pavement markings are to be paint and shall conform to Sherwin Williams Highway Products, Hotline Traffic Paints Premium Waterborne TM 2152 White or TM 2153 Lead Free Yellow. Gore transverse stripping is to be epoxy. All other pavement markings are to be cold inlaid plastic or hot surface applied thermoplastic. Pavement markings shall be repainted at the close of the 18-month maintenance period.

SOUTH WHITEHALL TOWNSHIP

TECHNICAL SPECIFICATIONS

STORM SEWERS AND APPURTENANCES

GENERAL: All materials and construction methods used in the construction of storm sewers and appurtenances shall meet the requirements as set forth in Pennsylvania Department of Transportation (PENNDOT) Specifications, Publication 408 except as specifically modified by the requirements herein, and except that the use of any type of slag, lightweight aggregate, or crushed concrete material is prohibited.

Materials

PIPE AND STRUCTURES: Reinforced concrete pipe (RCP) shall be used for all storm sewers to be constructed within street rights-of-way to be dedicated to the Township and may be used for storm sewers located within drainage easements. High density polyethylene (HDPE) pipe may be permitted by the Township in certain cases including in drainage easements outside of the street rights-of-way. Manholes shall be constructed of precast concrete manhole sections. Inlets and endwalls shall be precast reinforced concrete structures. Manholes and inlets shall not be constructed of precast concrete blocks or sewer brick. Sewer brick shall be used only at the top of the concrete structure to allow for slope adjustment of the casting. See Construction, LEVELING COURSE.

All materials shall be by a manufacturer listed in PENNDOT, Publication 35, Bulletin 15 (Approved Construction Materials).

HIGH DENSITY POLYETHYLENE PIPE (HDPE): HDPE pipe shall meet the requirements of AASHTO M252 or AASHTO M294, Standard Specification for polyethylene corrugated drainage pipe.

CONCRETE STORM SEWER PIPE, REINFORCED: Round and elliptical RCP shall conform to BD-636M, PENNDOT Design Manual Part 4M, Appendix H, and PENNDOT Publication 280M (280) (all current additions).

MORTAR: Mortar for brick masonry, pipe joints, and connections to other structures shall conform to the requirements of Pennsylvania Department of Transportation (PENNDOT) Specifications, Publication 408, Section 705.7.

RUBBER GASKET JOINTS: Joints using rubber gaskets shall conform to the requirements of AASHTO M198. Rubber gaskets for concrete pipe shall be continuous rubber rings which fit snugly in the annular spaces between the overlapping surfaces of the ends of the pipes to form a flexible watertight seal under all conditions of service. The gasket shall have smooth surfaces free from all imperfections.

CONCRETE: Plain and reinforced concrete used in structures, pipe cradles, connections of pipes with structures, low flow channels, support of structures or frames, etc. shall conform to the requirements of Pennsylvania Department of Transportation (PENNDOT) Specifications, Publication 408, Section 704, Class A concrete minimum.

BRICK: Brick shall conform to the requirements of AASHTO M91, Grade MM.

PRECAST CONCRETE PIPE MANHOLE SECTIONS: Precast reinforced concrete pipe manhole sections shall conform to the requirements of AASHTO M199. Unless otherwise approved by the Engineer, the sections shall have a minimum inside diameter of 48 inches.

FRAMES, COVERS, AND GRATE CASTINGS: Standard manhole castings shall be as shown on the Standard Construction Details – SWT-D-1 and inlet grates shall be as shown on Standard Construction Details – SWT-D-3.

All castings shall be true to form and dimensions, and shall be free from inclusions of foreign material, casting faults, injurious blow holes, cracks, sponginess, and other defects rendering them unsuitable. The finished frame and cover or grate shall have the bearing surfaces machined or ground so that there will be no variations that will permit rocking or rattling, and the diameter of the cover or grate shall be such as to fit the frame without wedging. All castings shall be thoroughly cleaned by the manufacturer.

Grates for inlets shall be bicycle safe as shown on Standard Construction Details – SWT-D-3.

STEPS: All manholes and inlets shall be provided with steps. Steps shall conform to PENNDOT Standards for Roadway Construction, current edition (PDT Pub #72M) RC-39M.

Construction

EQUIPMENT: The Contractor shall provide equipment to handle the pipe in unloading and placing in its final position, without damage to the pipe.

The Contractor shall provide mechanical and pneumatic tampers sufficient to obtain the compaction of the pipe bedding and backfill as specified.

Use of the Hydra-Hammer or impact type equipment similar to the Hydra-Hammer will not be permitted for compacting backfilled trenches.

EXCAVATION:

1. The Contractor shall perform all common excavation to the depth necessary for pipe installation as shown on the grade cut sheets reviewed by the Engineer;
2. The Contractor shall perform all rock excavation to the depth required for common excavation plus at least eight inches below the bottom of the pipe bedding.

When rock or non-cushioning material is encountered in trench excavation, a cushion at least eight inches thick shall be placed between the rock and the bottom of the pipe bedding. The cushion shall consist of clean sand or equivalent granular material meeting the requirements of AASHTO No. 10 aggregate or PENNDOT No. 2A stone. The bottom of the trench shall be excavated to a horizontal section as far as practicable.

Blasting may be considered only when proper precautions are taken for the safety of all persons, the work, and the property. All damage done to the work or property shall be repaired at the Developer's expense. All operations of the Developer in connection with the transportation, storage, and use of explosives shall conform to all federal, state and local regulations, explosive manufacturers' instructions, with applicable approved permits to be submitted to the authority having jurisdiction for review. Any review given, however, will not relieve the Developer of its responsibility in blasting operations.

Blasting shall be performed only after obtaining all necessary permits from state and local agencies and the Township, as applicable;

3. Should unstable soil be encountered or should the Engineer deem it necessary to excavate to a depth below the grade shown on the Plans to secure a good foundation, the Contractor shall remove the unstable soil for the full width of the trench and replace it with PENNDOT No. 2A stone or larger, as reviewed by the Engineer. The pipe bedding shall be constructed on top of the PENNDOT No. 2A stone. The Engineer or Geotechnical Engineer if necessary shall determine the depth of removal of unstable soil and the amount of backfill necessary. The backfill shall be thoroughly compacted and shaped to form the bed for the pipe;
4. Excavated material not required or acceptable for backfill shall be legally disposed of by the Contractor. Common excavation shall not be carried below the required depth. When this occurs, the trench shall be backfilled with material reviewed by the Engineer and compacted to the density of 100% of non-cohesive material or 95% for cohesive material of the Standard Proctor Density (AASHTO T 99 - Method C);
5. Where the bottom of the trench is found to be an inadequate foundation for the pipe and cannot be stabilized by the above methods, a concrete pad or cradle of sufficient size shall be constructed as determined by the Geotechnical Engineer;
6. The minimum width of the trench at the top of the pipe when placed shall be at least equal to the outside diameter of the pipe plus 12 inches on each side of the pipe. The trench shall be excavated accurately to the established line so that at least a 12-inch space will exist between the side of the trench and the side of the pipe. The maximum allowable width of trench shall not exceed 24 inches on each side of the pipe when placed;
7. The sides of trenches shall be vertical for a minimum distance of four feet above the top of the pipe. These requirements are for the stability of the trench and not to be confused with the safety issues of the trench. The Contractor shall perform such

vee-ing, trench bracing, sheathing, or shoring necessary to perform and protect the excavation and as required for safety and to conform to governing laws. Unless otherwise provided, bracing, sheathing, or shoring shall be removed by the Contractor as backfill progresses in strict accordance with all safety procedures and to conform to all governing laws; and

8. In the absence of more stringent limitations specifically defined herein or imposed by the Engineer, Township, or any other regulatory agency, the length of open trench shall be limited to 50 feet in advance of where pipe has been laid and 100 feet in total at any single location. Any open trenches shall be completely backfilled. Open trenches may be covered with steel plates only as reviewed by the Township on a case-by-case basis. All construction equipment shall be removed from within rights-of-way of existing public roadways at the end of each work day and immediately upon the temporary or permanent discontinuance of work.

BEDDING: Unless otherwise directed by the Engineer/Township, all pipe to be installed, including that which is laid on an eight inch cushion in areas of rock excavation, shall bear the full length on firm, flat compacted PENNDOT No. 2A stone bedding which is properly shaped to receive the pipe configuration at the joints. The bedding and initial backfill around the pipe shall be placed as follows:

1. For reinforced concrete pipe – minimum compacted thickness of four inches beneath the pipe;
2. For HDPE pipe – when compacted the granular bedding shall extend from a minimum of four inches beneath the pipe to a minimum of 12 inches over top of the pipe.

Wherever the Geotechnical Engineer may deem it necessary, the pipe shall be laid on a concrete pad or cradle of sufficient size to span areas of unsatisfactory bearing.

LAYING AND INSTALLING PIPE: Pipe shall be laid to true alignment and regular grade. Before pipe is laid, all dirt shall be removed from inside the pipe and all lumps, blisters, dirt, oil, grease and moisture shall be removed from inside and outside the ends. After pipe is laid, care shall be taken to prevent the entrance of dirt or water from the trench. Every open end of a pipe or fitting shall be plugged before leaving the work for the day or before backfilling the trench. Plugs shall be on the site before the Contractor commences construction of the pipe line.

Cutting of pipe for closure pieces, or other reasons, shall be done in a neat and workmanlike manner by a method which will not damage the pipe. All such cutting of pipe shall be done in conformance with the manufacturer's recommendations.

The Engineer/Township may inspect all pipe before it is laid, and reject any section that is damaged by handling or is found to be defective to a degree which will materially affect the function and service of the pipe.

Pipe shall not be laid on frozen ground. Pipe which is not true in alignment, or which shows any settlement after laying, shall be taken up and re-laid.

The Contractor shall provide, as may be necessary, for the temporary diversion of stream flow in order to permit the installation of the pipe under dry conditions.

DEWATERING: Any water which collects in any excavation shall be removed by the Contractor before proceeding with the construction of the pipeline or structures.

LINE AND GRADE: The location (line) and/or grade of all sewers and pipe lines to be constructed shall be established by means of offset stakes, pins or other survey marks. When the Contractor uses a laser to obtain line and grade for laying the pipe, periodic checks shall be made by the Contractor from grade stakes. The first grade stake shall be furnished at 25 feet and at intervals not greater than 100 feet thereafter. When the Observer checks for vertical and/or horizontal alignment of the pipe, the Contractor shall assist him. Grade cut sheets shall be prepared by the Developer's engineer and submitted to the Engineer for review a minimum of three working days prior to construction.

A minimum horizontal separation of ten feet and a minimum vertical separation of 18 inches shall be maintained between waterlines and sanitary or storm sewers in accordance with Pennsylvania Department of Environmental Protection Public Water Supply Manual, Part II, Community System Design Standards, Chapter 8, Section 8.7 inclusive, or latest version of the governing regulations. When conflicts occur with existing facilities and the separations are less than mentioned above, the corrective methods shall be reviewed by the Engineer/Township.

HIGH DENSITY POLYETHYLENE PIPE: HDPE shall be installed in accordance with the requirements of the PENNDOT Specifications, Publication 408, Section 601. However, in all installations, during construction the minimum depth from surface grades to top of pipe shall be 3 feet, and upon final grading the minimum depth from finished grade to top of pipe shall be 2 feet, unless greater depths are recommended by the pipe manufacturer. All pipe shall be watertight joints unless otherwise reviewed by the Geotechnical Engineer upon receipt of documentation to indicate that an alternative joint would be appropriate.

Repair of the damaged HDPE shall be according to the pipe manufacturer's recommendations. This shall include but is not limited to removal and replacement or a repair procedure acceptable to the Engineer/Township.

CONCRETE PIPE JOINTS: Joints for concrete storm sewer pipe shall be of the bell and spigot type.

One of the following methods of jointing pipe shall be used as determined by the Geotechnical Engineer: portland cement mortar (non-watertight joints) or rubber gasket (watertight joints). Alternative jointing pipe method shall be reviewed by the Geotechnical Engineer on a case by case basis.

When mortar is used, on the inside of the pipe the lower half of the joint shall be filled flush with mortar for pipes up to 27 inches in diameter. For these pipes where only the lower half of the joint is filled on the inside, then the upper half of the joint shall be filled on the outside of the joint. For pipes over 27 inches in diameter, the inside joint shall be filled flush with mortar for the entire inside periphery.

When a rubber gasket is used to make the joint, it shall be installed in accordance with the manufacturer's instructions.

BACKFILLING: Backfilling of trenches for pipes shall be accomplished in accordance with these specifications. All trenches and excavations shall be backfilled promptly after the pipes are installed. Method of backfilling shall be as follows:

1. Within State Highway Right-of-Way: Backfilling shall be done in accordance with requirements of the State Highway Occupancy Permit;
2. Within existing streets, the backfill shall consist of:
 - a. A proper bedding of granular material properly formed to fully support the entire length of pipe;
 - b. PENNDOT No. 2A stone for initial backfill of sides and top of the pipe to eight inches below the existing subgrade;
 - c. Where required by the Geotechnical Engineer/Township, eight inches of clay placed and compacted to seal the trench at the subgrade elevation;
 - d. In lieu of b. and c. above and with written approval from the Township, "flowable fill"; i.e., "Controlled Low Strength Material" (CLSM), with late-age strength of 80 psi to 100 psi may be placed to existing subgrade elevation. The 120-day settlement period (as referenced below) is replaced by the time required to reach late-age strength;
 - e. New base and surface courses at least equivalent to the material of the existing roadway, as determined by the Engineer; and
 - f. When excavation of an existing Township street is necessary, it shall be done in accordance with requirements of the Township; i.e., the Street Excavation and Occupancy Permit.
3. In all other areas (including but not limited to proposed streets) the backfill shall consist of:
 - a. A proper bedding of granular material properly formed to fully support the entire length of pipe;
 - b. Clean clay-like material or PENNDOT No. 2A stone for initial backfill of the sides and for 12 inches above the pipe. For HDPE pipe, only PENNDOT No. 2A shall be used to 12 inches above the pipe, which envelope shall be maintained throughout the construction period and shall not extend into subbase materials for roadways;

- c. Approved material free from organic matter, large or frozen lumps or stones over ten inches in their largest dimensions. Stones which are used in backfilling shall be so distributed through the mass that all interstices are filled with fine material.

The material shall be moistened or dried, if necessary, to obtain the required compaction. Backfill material shall be reviewed by the Engineer. The use of slag, lightweight aggregate, or crushed concrete in any form for bedding or backfill is prohibited. Special care shall be taken in placing the backfill. Particular care shall be used to obtain thorough compaction under the haunches and along the sides to the top of the pipe.

All backfill shall be placed in loose layers not exceeding six inches in depth under and around the pipe, and not exceeding eight inch lifts over the pipe. Successive layers shall be added and thoroughly compacted by mechanical and pneumatic tampers until the trench is completely filled to the elevation as directed. Backfilling shall be done in such a manner as to avoid injurious top or side pressures on the pipe.

Underground warning tape shall be installed a minimum of two feet above any pipe in the backfill of any mainline or lateral trench. Tape shall be alkali resistant, 4 mils polyethylene, 4 inches minimum width, continuously printed with name or symbol of utility buried below, color coded as follows:

Red: Electric.

Yellow: Gas, oil, and dangerous materials.

Orange: Telephone, cable TV, and other communications.

Blue: Water systems.

Green: Sewerage systems.

Where plastic pipe water or sewer pipe is used the tape shall be appropriately colored and able to conduct a signal generated by a locating device.

Backfill shall be compacted to a density of not less than 95% of maximum density for cohesive material and 100% for non-cohesive material. The maximum density is the maximum dry weight density in pounds per cubic foot as determined by the Standard Proctor Density (AASHTO T 99 - Method C).

All backfilled trenches shall be allowed to settle for at least 120 days before the permanent base course or pavement may be constructed. Where less than 120 days of settlement time is anticipated and permitted by the Engineer, all trench backfill shall be PENNDOT No. 2A stone, compacted and when required by the Geotechnical Engineer/Township, capped with eight inches of clay at subgrade elevation, wherever permanent base course and pavement is to be constructed. In such cases, the delay time until paving is permitted is to be determined by the Engineer/Township.

APPURTENANCES: Manholes, inlets, and endwalls shall be constructed to the requirements of PENNDOT Specifications, Publication 408, Section 605 and Section 714; the latest details of the PENNDOT Standards for Roadway Construction; these Specifications and the Standard Construction Details.

LEVELING COURSE: A leveling course of precast concrete adjustment units shall be provided at all manholes and inlets to set each casting at final grade. Brick is to be used for slope adjustment only, and the inside and outside surfaces of the masonry leveling course shall be neatly plastered with mortar to a minimum thickness of one-half inch.

PLACEMENT AND TREATMENT OF CASTINGS, FRAMES AND FITTINGS: All castings, frames, and fittings shall be placed in the positions indicated on the Plans or as directed by the Engineer, and shall be set true to line and to correct elevation. If frames or fittings are to be set in concrete or cement mortar, all anchors or bolts shall be in place and positioned before the concrete or mortar is placed. The unit shall not be disturbed until the mortar or concrete has set.

There shall be three weepholes placed in each inlet, as directed by the Engineer/Township. The minimum size of each weephole shall be two inches by four inches. The weepholes shall be placed in the top of the base unit (called "Inlet Box" by the PENNDOT -- Standards for Roadway Construction) or in the leveling course between the "Inlet Box" and the Concrete Top Units. The weepholes shall be spaced evenly unless otherwise directed by the Engineer. The backfill around the weepholes shall not be screened; i.e., place clean stone without screening the voids to allow water to enter the weepholes.

INSTALLATION OF STEPS: The steps shall be installed as indicated on the Plans, or as directed by the Engineer. When the steps are to be set in concrete they shall be placed and secured in position before the concrete is poured. The steps shall not be disturbed or used until the concrete or mortar has hardened for at least seven days. After this period has elapsed, the steps shall be cleaned and painted, unless they have been galvanized, or coated satisfactorily.

When steps are required with precast concrete pipe structures, they shall be cast into the sides of the pipe at the time the pipe sections are manufactured, or set in place after the structure is erected by drilling holes in the concrete and cementing the steps in place.

Typical step configuration shall be in accordance with PENNDOT Standards for Roadway Construction, detail for STANDARD MANHOLES, PRECAST MANHOLES & MANHOLE STEPS, RC-39M.

BACKFILLING OF STRUCTURES:

1. After a structure has been completed, the area around it shall be filled with approved material, in horizontal layers not to exceed eight inches in loose depth, and compacted to the density specified. The fill shall be made to the elevation shown on the Plans, or as directed by the Engineer/Township;
2. Backfill shall not be placed against any structure until concrete is given the necessary time to cure;

3. Fill shall be deposited uniformly around the structure while backfilling to prevent unequal lateral pressure. Special care shall be taken to prevent any wedging action against the structure.

UNDERDRAIN: Pipe underdrain shall meet the requirements of PENNDOT Specifications, Publication 408, Section 610 and be reviewed by the Engineer. Inside diameter of pipe shall be six inches, unless otherwise shown on the approved plans.

SECURITY GRATES: Security grates shall be installed on all headwalls, endwalls, end sections, and culverts with openings 15 inches or greater. It shall be the responsibility of the Developer or its Contractor to submit to the Engineer for review a detailed drawing of the proposed security grate prior to fabrication. The number of bars shall be determined by the culvert size with bar spacing not to exceed six inches each way. Structural steel shall conform to ASTM A36 and bars shall conform to ASTM A615, Grade 60, epoxy coated or hot-dipped galvanized after fabrication. Grates shall be attached to the structures in a manner permitting ready removal for future cleaning of debris.

DETENTION BASINS: The construction of detention basins shall meet the requirements of PENNDOT Specifications, Publication 408, Sections 200 and 800 and be reviewed by the Engineer/Geotechnical Engineer.

In cut areas or in embankment areas, the upper six inches of the subgrade material beneath the clay blanket, within detention basin construction limits shall be compacted to a density of not less than 95% of maximum density for cohesive material and 100% for non-cohesive material. Maximum density is the maximum dry weight density in pounds per cubic foot as determined by the Standard Proctor Density (AASHTO T 99 - Method C). The basin shall be seeded with PENNDOT Formula D unless specified otherwise by the designer.

Any required impervious liner shall be as recommended by the Geotechnical Engineer.

The fence around detention basins shall meet the requirements of the Standard Construction Details – DETENTION BASIN FENCE AND OPEN-SPACE FENCE – SWT-D-8. The Developer is required to install either a permanent fence or a temporary fence prior to the basin detaining water. Signs reading “DANGER – KEEP OUT!”, in accordance with current ANSI Standards, shall be attached to the fence at maximum 50-foot intervals.

UNDERGROUND DETENTION FACILITIES: Underground detention facilities may be constructed of either: reinforced concrete vaults or tanks, large diameter plastic, metal or concrete pipe or commercially-available proprietary underground systems. The underground detention facilities shall be designed by the Developer’s design engineer and/or geotechnical engineer and reviewed by the Engineer/Geotechnical Engineer. All materials used in the construction of underground detention facilities shall be watertight, and any required impervious liner shall be as recommended by the Geotechnical Engineer.

Underground detention facilities must be located a minimum of 10 feet horizontally from other public utilities, 50 feet horizontally from a private well or septic system tank/drain field, and 15 feet down gradient or 100 feet up gradient from building foundations. Percolation tests and test pits or borings must be performed in the location of the proposed underground detention facility as determined to be necessary by the Geotechnical Engineer.

All reinforced concrete vaults or tanks and pipes, bedding and backfill shall be designed to withstand HS-25 loading. All vaults, tanks and pipes shall be continuously sloped at a minimum of 0.25 percent to the outlet. The minimum pipe diameter shall be 36 inches, and pipes may not be closer to one another than $\frac{1}{2}$ the inside pipe diameter or 3 feet, whichever is greater. A minimum 6 inches pipe bedding shall be provided, and the minimum backfill and cover must be per the manufacturer's specifications, based on the design load and considering flotation, where required. An emergency spillway shall be provided to safely pass the 100 year storm event.

A water quality treatment BMP shall be provided upstream of the underground detention facility. A minimum of one 30 inch diameter access port shall be provided for each vault or tank. A minimum of one 48 inch diameter manhole shall be provided for every 150 feet of pipe with a minimum of two 48 inch diameter manholes for each underground piping facility. Access shall also be provided at the outflow structure. All access ports/manholes shall be bolted.

CLEANING AND RESTORATION OF SITE: After the backfill is completed, the Contractor shall dispose of all surplus material, dirt, and rubbish from the site.

After the work is completed, the Contractor shall remove all tools and other equipment used, leaving the entire site in good condition.

FINAL OBSERVATION: Prior to final approval of the storm sewerage system, the Township, the Engineer, and the Developer accompanied by the Contractor's representative, shall thoroughly observe the entire installation. Any indication of defects in material or workmanship or obstruction to flow in the pipe system shall be further investigated and corrected by the Contractor.

TESTING: The Township may require infiltration/exfiltration testing of the storm sewers in accordance with ASTM C969-02 as may be updated or modified. The testing would be conducted by, and at the expense of, the Developer/Contractor.

NOTIFICATION: No connections shall be made to existing Municipal systems without prior approval and without three working days advance notice to the Township to allow for scheduling of Township observation personnel.

SINKHOLES: It is required that the Developer maintain all areas in a well-drained condition during the construction period so as to avoid pooling or ponding of water. If a sinkhole should develop during construction, the Developer shall immediately repair the sinkhole at its expense alone and in accordance with the following:

Upon detection of a sinkhole, the Developer or its Contractor shall notify the Township, contact its own geotechnical engineer who shall propose a repair solution and have that procedure reviewed by the Geotechnical Engineer. The Developer's geotechnical engineer

and the Geotechnical Engineer shall monitor the repair in accordance with the reviewed procedure and upon completion of the repair and before any construction activity resumes in the area, the Developer's geotechnical engineer shall send a written report to the Township and to the Geotechnical Engineer that the sinkhole has been repaired in accordance with the reviewed procedure and that construction activities may continue.

SOUTH WHITEHALL TOWNSHIP AUTHORITY

TECHNICAL SPECIFICATIONS

WATER MAINS AND APPURTENANCES

GENERAL: All materials and construction methods used in the construction of water mains and appurtenances shall meet the requirements as set forth in Pennsylvania Department of Transportation (PENNDOT) Specifications, Publication 408 except as specifically modified by the requirements herein, and except that the use of any type of slag, lightweight aggregate, or crushed concrete material is prohibited.

Materials

ANSI/NSF STANDARDS: All materials to be used in construction or modification of a public water system including waterline extensions which may come in contact with or affect the quality of the water shall be certified for conformance with ANSI/NSF Standard 61 (Drinking Water System Components - Health Effects - National Sanitation Foundation). An acceptable certification shall be provided by the NSF or other certification organization acceptable to the Pennsylvania Department of Environmental Protection.

DUCTILE IRON PIPE: All pipe shall be Ductile Iron centrifugally cast in accordance with ANSI Specification A21.51 and shall have a Class 52 metal thickness.

PIPE JOINTS: All joints shall be of the push-on type except as noted and shall conform to ANSI Specification A21.11. Pipe shall be furnished complete with all joint accessories including the continuous, molded, rubber ring gasket and the gasket lubricant.

FITTINGS: All fittings shall conform to ANSI Specification A21.10 for ductile iron and gray iron fittings for 3-inch through 48-inch diameters for water and other liquids or to ANSI Specification A21.53 for ductile iron compact fittings for 3-inch to 12-inch diameters for water and other liquids.

CEMENT LINING: All pipe and fittings shall be double cement lined and asphaltic seal coated inside, and bituminous seal coated outside in accordance with ANSI Specification A21.4. Minimum thickness of double cement lining shall be 1/8 inch.

EPOXY COATING: All fittings should be epoxy coated inside and bituminous seal coated in accordance with ANSI/AWWA C116/A21.16.

VALVE, VALVE BOX, AND TAPPING SLEEVE AND VALVE: Refer to Standard Construction Details – VALVE AND VALVE BOX – SWT-W-6.

FIRE HYDRANTS: Fire hydrants shall conform to AWWA Specification C502 and shall be as shown on the Standard Construction Details – FIRE HYDRANT – SWT-W-1.

SERVICE CONNECTIONS: Refer to Standard Construction Details – SERVICE CONNECTION – SWT-W-5.

BLOW-OFF ASSEMBLY: Refer to Standard Construction Details – WATERLINE BLOW-OFF – SWT-W-4.

COPPER SERVICE LINES: Service connections from the main to the curb stop of sizes 1-inch (minimum) through 2-inch diameter shall be Type K copper tubing, conforming to ASTM B88 (current issue), designed for a working pressure of not less than 150 psi. The copper service line shall be one continuous section of copper tubing from the corporation to the curb stop and shall not include any couplings.

DUCTILE IRON SERVICE LINES: Service connections from the main to the curb stop of sizes larger than 2-inch diameter shall be ductile iron conforming to the AWWA C151 and C153.

CONCRETE: All concrete required for thrust blocks, concrete mats, etc. shall conform to the requirements of Pennsylvania Department of Transportation (PENNDOT) Specifications, Publication 408, Section 704, Class A concrete minimum.

METER PITS: Refer to Standard Construction Details – WATER METER/DOUBLE CHECK DETECTOR ASSEMBLY AND PIT – SWT-W-7, and CAMPUS WATER METER AND PIT – SWT-W-8. For meter pits for residential fire-protection services, refer to Standard Construction Details – WATER METER PIT FOR 1-INCH METER – SWT-W-12. The Developer shall verify that the meter and meter reading equipment is compatible with that required by the Township prior to installation.

PUMP STATIONS: Detailed plans, design calculations, and specifications for all water booster pumping stations or other special installations shall be submitted for review by the Engineer/Township. The Developer shall arrange with the manufacturer to provide the services of a factory-trained representative to perform the initial start-up of the station and to instruct the operating personnel in the operation and maintenance of the station. In addition, three copies of a complete operating and maintenance manual shall be provided to the Engineer before the station will be accepted by the Township. The station shall be designed and constructed so as to be controlled and monitored by the Township's S.C.A.D.A. System. All programming and connection costs are to be borne by the Developer.

BRASS: All brass materials shall be lead free.

SAMPLE STATION: Refer to Standard Construction Details – SAMPLE STATION – SWT-W-11.

WATER METERS: A meter jack will be provided by the Township when the Plumbing Permit is issued. After the contractor installs all piping and valves, the Township will remove the jack and install the meter and tail pieces. Water meters and appurtenances shall be installed as shown and described on Standard Construction Details – ¾"-2" WATER METER ASSEMBLY – SWT-W-10.

Construction

EQUIPMENT: The Contractor shall provide equipment to handle the pipe in unloading and placing in its final position, without damage to the pipe.

The Contractor shall provide mechanical and pneumatic tampers sufficient to obtain the compaction of the pipe bedding and backfill as specified.

Use of the Hydra-Hammer or impact type equipment similar to the Hydra-Hammer will not be permitted for compacting backfilled trenches.

EXCAVATION:

1. The Contractor shall perform all common excavation to the depth necessary for pipe installation as shown on the grade cut sheets reviewed by the Engineer to provide 4 feet of cover from final grade. Any deviation over 1 foot requires approval of the Township Engineer and Public Works Department.
2. The Contractor shall perform all rock excavation to the depth required for common excavation plus at least 8 inches below the bottom of the pipe bedding.

When rock or non-cushioning material is encountered in trench excavation, a cushion at least 8 inches thick shall be placed between the rock and the bottom of the pipe bedding. The cushion shall consist of clean sand, granular material meeting the requirements of AASHTO No. 10 aggregate, or PENNDOT No. 2A stone. The bottom of the trench shall be excavated to a horizontal section as far as practicable.

Blasting may be considered only when proper precautions are taken for the safety of all persons, the work, and the property. All damage done to the work or property shall be repaired at the Developer's expense. All operations of the Developer in connection with the transportation, storage, and use of explosives shall conform to all federal, state and local regulations, explosive manufacturers' instructions, with applicable approved permits to be submitted to the authority having jurisdiction for review. Any review given, however, will not relieve the Developer of its responsibility in blasting operations.

Blasting shall be performed only after obtaining all necessary permits from state and local agencies and the Township, as applicable, and notifying the Township prior to each day of blasting;

3. Should unstable soil be encountered or should the Engineer deem it necessary to excavate to a depth below the grade shown on the Plans to secure a good foundation, the Contractor shall remove the unstable soil for the full width of the trench and replace it with PENNDOT No. 2A stone or larger, as reviewed by the Engineer. The pipe bedding shall be constructed on top of the PENNDOT No. 2A stone. The Engineer/Geotechnical Engineer shall determine the depth of removal of unstable soil and the amount of backfill necessary. The backfill shall be thoroughly compacted and shaped to form the bed for the pipe;

4. Excavated material not required or acceptable for backfill shall be legally disposed of by the Contractor. Common excavation shall not be carried below the required depth. When this occurs, the trench shall be backfilled with material reviewed by the Engineer and compacted to 95% for cohesive material and 100% for non-cohesive material of the Standard Proctor Density (AASHTO T 99 - Method C);
5. Where the bottom of the trench is found to be an inadequate foundation for the pipe and cannot be stabilized by the above methods, a concrete pad or cradle of sufficient size shall be constructed as determined by the Geotechnical Engineer;
6. The minimum width of the trench at the top of the pipe when placed shall be at least equal to the outside diameter of the pipe plus 12 inches on each side of the pipe. The trench shall be excavated accurately to the established line so that at least a 12-inch space will exist between the side of the trench and the side of the pipe. The maximum allowable width of trench shall not exceed 24 inches on each side of the pipe when placed;
7. The sides of the trenches shall be vertical for a minimum distance of 4 feet or a maximum distance of 5 feet above the top of the pipe. These requirements are for the stability of the trench and not to be confused with the safety issues of the trench. The Contractor shall perform such vee-ing, trench bracing, sheathing, or shoring necessary to perform and protect the excavation and as required for safety and to conform to governing laws. Unless otherwise provided, bracing, sheathing, or shoring shall be removed by the Contractor as backfill progresses in strict accordance with all safety procedures and to conform to all governing laws;
8. In the absence of more stringent limitations specifically defined herein or imposed by the Engineer, Township, or any other regulatory agency, the length of open trench shall be limited to 50 feet in advance of where pipe has been laid and 100 feet in total at any single location. Any open trenches shall be completely backfilled. Open trenches may be covered with steel plates only as reviewed by the Township on a case-by-case basis. All construction equipment shall be removed from within rights-of-way of existing public roadways at the end of each work day and immediately upon the temporary or permanent discontinuance of work.

BEDDING: Unless otherwise directed by the Engineer, all pipe, including that which is laid on an 8-inch cushion in areas of rock excavation, shall bear the full length on a firm, flat trench bottom of a minimum of 4 inches of PENNDOT No. 2A stone, properly shaped to receive the pipe configuration at the joints. Wherever the Geotechnical Engineer may deem it necessary, the pipe shall be laid on a concrete pad or cradle of sufficient size to span areas of unsatisfactory bearing.

LAYING AND INSTALLING PIPE: Pipe shall be laid to true alignment and regular grade. Any change in horizontal direction which exceeds the deflection tolerance recommended by the pipe manufacturer shall be made by restrained fittings. The waterline shall be installed to provide 4 feet of cover from final grade, unless otherwise permitted by the Engineer/Township. Where required to install the waterline deeper to avoid conflicts with other utilities, deflect the waterline

with the use of 45-degree bends and return to 4 feet of cover. Water valves shall be placed at depths no greater than 4 feet.

Cutting of pipe for closure pieces, or other reasons, shall be done in a neat and workmanlike manner by a method which will not damage the pipe. Cut ends of the pipe shall be ground smooth and beveled as recommended by the manufacturer.

The Engineer/Township may inspect all pipe before it is laid, and reject any section that is damaged by handling or is found to be defective to a degree which will materially affect the function and service of the pipe.

Pipe shall not be laid on frozen ground. Pipe which is not true in alignment, or which shows any settlement after laying, shall be taken up and re-laid.

The Contractor shall provide, as may be necessary, for the temporary diversion of stream flow in order to permit the installation of the pipe under dry conditions.

Push-on joints shall be applied in accordance with the manufacturer's recommendations, with special care given to cleaning the joint and gasket thoroughly, applying the recommended lubricant, positioning the gasket carefully and avoiding any contact which might tend to cut the gasket. Where mechanical joints are specified, similar care shall be exercised. Mechanical joints shall be made as recommended by the manufacturer.

Pipes, fittings, hydrants and valves shall be carefully handled so as to avoid damage or contamination. Before pipe is laid, all dirt shall be removed from inside the pipe and all lumps, blisters, dirt, oil, grease and moisture shall be removed from inside and outside the ends. After pipe is laid, care shall be taken to prevent the entrance of dirt or water from the trench. Every open end of a pipe or fitting shall be plugged before leaving the work for the day or before backfilling the trench. Plugs shall be on the site before the Contractor commences construction of the waterline.

Concrete thrust blocks shall be poured at all tees, horizontal bends, plugs, and fire hydrants. At each vertical bend in the main, or such other location specifically reviewed by the Engineer, the Contractor shall install concrete thrust blocks and shall take one or more of the following additional steps to prevent movement of the pressurized pipe:

1. Use "Mega-lug" retainer glands as manufactured by EBAA Iron Sales, Inc. Any restrained fitting shall be no closer than 50 feet from an unrestrained pipe joint;
2. Use steel "all-thread" rods from fitting to fitting and a harness from fitting to the pipe; the type, number and location of which will depend on field conditions, but in no case shall be less than 50 feet from the fitting; and
3. Use other methods satisfactory to the Engineer/Township Public Works Department.

Pipe sleeves, couplings, bell clamps, etc. shall not be used in the completed installation.

DEWATERING: Any water which collects in an excavation shall be removed by the Contractor before proceeding with the construction of the pipeline or structure.

LINE AND GRADE: The location (line) and grades, if deemed necessary by the Engineer for the water main, shall be established by means of offset stakes, pins or other survey marks. Grades, when necessary, shall be furnished at intervals of 50 feet, minimum. Grade cut sheets shall be prepared by the Developer's Engineer and submitted to the Engineer for review a minimum of three working days prior to construction.

A minimum horizontal separation of 10 feet and a minimum vertical separation of 18 inches shall be maintained between waterlines and sanitary or storm sewers in accordance with Pennsylvania Department of Environmental Protection Public Water Supply Manual, Part II, Community System Design Standards, Chapter 8, Section 8.7 inclusive, or latest version of the governing regulations. When conflicts occur with existing facilities and the separations are less than mentioned above, the corrective methods shall be reviewed by the Engineer/Township.

SETTING VALVES, FIRE HYDRANTS AND FITTINGS: Valves for fire hydrants shall be located 4 feet in front of the curb or as directed by the Engineer/Township. Main line valves in general shall be located on the extensions of right-of-way lines of intersecting streets. Particular care shall be taken to see that all valves are in proper working order. Construction of waterlines in developments consisting of Phases or Sections shall be accomplished in such a manner that subsequent Phases or Sections can be constructed without disruption of water service to a previous Phase or Section. This requirement may involve the installation of valves and/or blow-off assemblies additional to those shown on the plans. These valves and/or blow-off assemblies shall be secured by a method reviewed by the Engineer/Township (see LAYING AND INSTALLING PIPE) or secured by extending the line a minimum of one full pipe length past the valve and by backfilling properly. This extension shall be capped with a blow-off assembly and be pressure tested as described herein. The valve shall be tested with a listening device as described herein. Care shall be taken in setting the mainline valve so that the pipe extension terminates at the project limit. Where hydrant tees are allowed, hydrant valves shall be secured to the hydrant tee using acceptable fastening methods.

Fire hydrants shall be set to line and grade and located as shown on the Standard Construction Details – FIRE HYDRANT – SWT-W-1 or as directed by the Engineer/Township Public Works Department. Excavations for fire hydrants shall be three feet square and extend down to a depth 18 inches below the bottom of the hydrant. The excavation shall be filled to the bottom of hydrant elevation with AASHTO No. 3 stone. Hydrants shall be set with the 4-1/2-inch pumper connection facing the street, unless otherwise directed by the Engineer/Township Public Works Department. After setting the hydrant, AASHTO No. 3 stone shall be placed to 6 inches above the flange, and the balance of the excavation filled with suitable material. Particular care shall be taken to set all hydrants vertical and to see that they are in proper working order. Thrust blocks shall not cover the hydrant drains. The traffic break-away section shall be no greater than 4 inches above final grade.

Blow-off valves and other fittings shall be installed where shown on the plans, or as directed by the Engineer/Township Public Works Department and as shown on the Standard Construction Details – WATERLINE BLOW-OFF – SWT-W-4.

SERVICE LATERALS: Service laterals shall be installed from the main to the curb stop, which shall be located generally two feet behind the curb, four feet deep below the top of the curb or existing road grade. Corporations, curb stops, and laterals shall be installed only when the water main is at normal working pressure, and shall be observed by the Engineer/Township Public Works Department prior to backfilling. Bury depth shall not be greater than five feet nor less than four feet. An eight inch clay envelope shall be placed around all copper service laterals.

Curb boxes shall be positioned over the curb stops so that there is equal adjustment above and below final grade. The final check of the curb box alignment shall be made by the Observer and personnel of the Township or agency having jurisdiction. A curb stop key shall be satisfactorily placed on every curb stop, if alignment is in question. Curb boxes shall not be located in sidewalks, driveways, or driveway aprons.

When directed by the Engineer/Township Public Works Department, the water lateral shall be extended from the curb stop to a location ten feet from the property line toward the house. This extension is commonly referred to as the "pigtail" of the water lateral. The end of the "pigtail" shall be marked by installing a two lb. per ft. steel post painted with a fluorescent blue paint extending from the pipe end to five feet above grade.

BACKFILLING: Backfilling of trenches for pipes which are to be conveyed to the Township shall be accomplished in accordance with these specifications. All trenches and excavations shall be backfilled promptly after the pipes are installed. Method of backfilling shall be as follows:

1. Within State Highway Right-of-Way: Backfilling shall be done in accordance with requirements of the State Highway Occupancy Permit;
2. Within existing streets, the backfill shall consist of:
 - a. A proper bedding of granular material properly formed to fully support the entire length of pipe;
 - b. PENNDOT No. 2A stone for initial backfill of sides and top of the pipe to eight inches below the existing subgrade;
 - c. Where required by the Geotechnical Engineer/Township, eight inches of clay placed and compacted to seal the trench at the subgrade elevation;
 - d. In lieu of b. and c. above and with written approval from the Township, "flowable fill"; i.e., "Controlled Low Strength Material" (CLSM), with late-age strength of 80 psi to 100 psi may be placed to existing subgrade elevation. The 120-day settlement period (as referenced below) is replaced by the time required to reach late-age strength;
 - e. New base and surface courses at least equivalent to the material of the existing roadway classification or equivalent to the material of the existing roadway (whichever is greater), as determined by the Engineer;

- f. When excavation of an existing Township street is necessary, it shall be done in accordance with requirements of the Township; i.e., the Street Excavation and Occupancy Permit.
3. In all other areas (including but not limited to proposed streets) the backfill shall consist of:
 - a. A proper bedding of granular material properly formed to fully support the entire length of pipe;
 - b. Clean clay-like material or PENNDOT No. 2A stone for initial backfill of the sides and for 12 inches above the pipe;
 - c. Approved material free from organic matter, large or frozen lumps or stones over ten inches in their largest dimensions. Stones which are used in backfilling shall be so distributed through the mass that all interstices are filled with fine material.

The material shall be moistened or dried, if necessary, to obtain the required compaction. Backfill material shall be reviewed by the Engineer. The use of slag, lightweight aggregate or crushed concrete in any form for bedding or backfill is prohibited. Special care shall be taken in placing the backfill. Particular care shall be used to obtain thorough compaction under the haunches and along the sides to the top of the pipe.

All backfill shall be placed in loose layers not exceeding six inches in depth under and around the pipe, and not exceeding eight inch lifts over the pipe. Successive layers shall be added and thoroughly compacted by mechanical and pneumatic tampers until the trench is completely filled to the elevation as directed. Backfilling shall be done in such a manner as to avoid injurious top or side pressures on the pipe.

Underground warning tape shall be installed a minimum of two feet above any pipe in the backfill of any mainline or lateral trench. Tape shall be alkali resistant, 4 mils polyethylene, 4 inches minimum width, continuously printed with name or symbol of utility buried below, color coded as follows:

Red: Electric.

Yellow: Gas, oil, and dangerous materials.

Orange: Telephone, cable TV, and other communications.

Blue: Water systems.

Green: Sewerage systems.

Where plastic water or sewer pipe is used the tape shall be appropriately colored and able to conduct a signal generated by a locating device.

Backfill shall be compacted to a density of not less than 95% for cohesive material and 100% for non-cohesive material of maximum density. The maximum density is the maximum dry weight density in pounds per cubic foot as determined by the Standard Proctor Density (AASHTO T 99 - Method C).

All backfilled trenches shall be allowed to settle for at least 120 days before the permanent base course or pavement may be constructed. Where less than 120 days of settlement time is anticipated and permitted by the Engineer, all trench backfill shall be PENNDOT No. 2A stone, compacted and when required by the Geotechnical Engineer/Township, capped with 8 inches of clay-like material at subgrade elevation, wherever permanent base course and pavement is to be constructed. In such cases, the delay time until paving is permitted is to be determined by the Engineer/Township.

FILLING, DISINFECTION, AND TESTING PROCEDURES: It shall be the responsibility of the Developer and/or its Contractor to notify South Whitehall Township Public Works Department (610-398-0407) prior to performing each of the following consecutive procedures. Forty-eight hours notice is required before each of the following procedures.

1. FILLING OF MAINS
2. DISINFECTION OF COMPLETED MAINS
3. DISINFECTION OF TAPPING SLEEVES
4. LOW VOLUME PURGE
5. BACTERIOLOGICAL TESTS
6. HYDROSTATIC TESTS
7. TESTING VALVES
8. HIGH RATE FLOW TEST

Water during this test shall be discharged through pipe and fittings assembled as shown and described on Standard Construction Details – HIGH-VOLUME FLUSHING APPARATUS – SWT-W-9.

1. FILLING OF MAINS: Filling of mains is under the complete control of the Township when the water used for filling is from a Township source. A Record Plan drawing of the segment of the system to be filled shall be available to the Township prior to filling the main. In lieu of Record Plans at this time, two sets of a schematic "line" diagram of the water system shall be prepared by the Contractor and given to the Superintendent or Foreman of Water to review before the Township will fill the lines. All valves and fire hydrants shall be shown on this diagram. A Township waterworks operator will monitor all filling.
2. DISINFECTION OF COMPLETED MAINS: Before being placed in service, the newly constructed water main shall be disinfected and tested in accordance with AWWA C651 and as specified herein. Chlorine may be applied by use of calcium hypochlorite comparable to commercial products known as H.T.H., Perchloron, or Maxochlor. This procedure will be under the control of a Township waterworks operator who will confirm that all applicable backflow and cross connection precautions are followed.

The chlorinating agent shall be applied in such a manner to treat completely all sections of the system. The chlorinating agent shall be applied in a quantity to produce a dosage of 25 mg/l to 50 mg/l of free chlorine. Disinfection shall continue

for a minimum of 24 hours and the residual free chlorine at the end of that time shall be a minimum of 10 mg/l.

During the chlorination process all valves and accessories shall be operated.

3. DISINFECTION OF TAPPING SLEEVES: The developer or its Contractor shall thoroughly clean the exterior of the main to be tapped and the interior surface of the tapping sleeve, and shall swab the interior surface of the tapping sleeve with sodium hypochlorite liquid.
4. LOW VOLUME PURGE: After chlorination, the heavily chlorinated water shall be purged from the line at its extremities through a dechlorinator until the test results of the replacement water are equal chemically and bacteriologically to those of the permanent source of supply. All flushing will be controlled by a Township waterworks operator. The individual service lines shall also be properly flushed. The purged water shall contain no more chlorine or other residual than allowed by the Pennsylvania Department of Environmental Protection or any other agency having jurisdiction.
5. BACTERIOLOGICAL TESTS: After all of the above testing is satisfactory, samples for the bacteriological tests shall be taken by an independent testing laboratory, certified by the Pennsylvania Department of Environmental Protection and approved by the Township waterworks operator. Samples shall be taken at the locations designated by the Engineer/Township Public Works Department and in accordance with AWWA C651. The Developer or its Contractor shall pay for the tests and shall direct the laboratory to submit only the test results directly to the Engineer (FAX 610-791-1256) and the Township Public Works Department (FAX 610-398-6898). The result for coliform bacteria shall be 0 per 100 ml, and the result for heterotrophic bacteria shall be <500 per 100 ml. The concentration of available chlorine shall be between 0.4 mg/l and 1.2 mg/l.

Valves isolating new lines from mains already in service shall not be opened until the customary water test certificates have been received from the testing laboratory and approved by the Township waterworks superintendent.

If water quality test results do not meet the Township's minimum standards for water quality, the Contractor shall repeat the disinfection process until acceptable water quality is achieved. The cost of initial water quality testing and any subsequent testing shall be borne by the Developer.

6. HYDROSTATIC TESTS:

CAUTION FOR PRESSURE TESTING: The following caution is applicable to all pressure testing on the project.

CAUTION. When piping systems are pressure tested, it is extremely important and essential that all plugs including test plugs and all pipe joints are installed and restrained in such a way that blowouts are prevented. It must be realized that sudden

expulsion of a poorly installed plug or section of pipe or of a test plug which is partially deflated before the pipe pressure is released can be very dangerous. For this reason it is recommended that every plug and pipe joint be positively braced or otherwise restrained during pressure testing and that no one be allowed in the vicinity of an exposed plug or pipe so long as pressure is maintained in the line.

The complete system shall be tested by one of the following methods:

- a. Before completely backfilling the joints but with sufficient material placed to hold the pipe during the test, the complete installation including the service laterals and fire hydrant (valves to hydrants open) laterals shall be tested at a hydrostatic pressure of 150 psig, or 50 psig greater than working pressure, whichever is higher. Note that all corporations, curb stops, miscellaneous fittings, etc. must be rated for 150 psi or greater to test with this method;
- b. In lieu of the above requirement and prior to the installation of the service laterals, the water mains alone may be tested at a hydrostatic pressure of 150 psig, or 50 psig greater than working pressure, whichever is higher. After the service laterals are installed the complete installation, including the service laterals, shall be re-tested at a hydrostatic pressure of 100 psig, for a minimum of one hour. During the re-test at 100 psig, the laterals are assumed to be partially backfilled.

All corporations shall be installed at normal working pressure (min.) and each corporation, service lateral, and curb stop shall be visually checked for leaks or defects under normal line pressure.

Any corporations which are tapped into the waterline for the purpose of testing (or expelling air) shall be removed and replaced with appropriate plugs following the completion of the testing.

Each section tested shall be slowly filled with water, care being taken to expel all air from the pipes. All control valves from the Township system shall only be operated by Township personnel. If necessary the pipes shall be tapped at high points to vent the air. The required pressure shall be applied for not less than three hours and all pipe, fittings, valves, hydrants and joints shall be carefully examined for defects. Leaking joints shall be made tight and defective work replaced until the leakage is reduced to the allowable amount, which shall be determined by the following formula:

$$L = \frac{SD(P)^{1/2}}{133,200}, \text{ where}$$

L = allowable leakage, in gallons per hour;

S = length of pipe tested, in feet;

D = pipe diameter, in inches;

(P)^{1/2} = square root of the test pressure, P, in pounds per square inch gauge (psig).

For fire lines, the Township Fire Inspector shall be notified at 610-398-0401.

7. TESTING VALVES: The following procedure is given as a guideline for testing the valves. Other procedures may be acceptable, and can be offered as an alternative for review by the Engineer. After the pressure test(s) are completed, every internal valve shall be checked for leaks in the following manner:
 - a. Starting at the most remote point from the source of pressure, each valve shall be closed;
 - b. As each valve is closed, the pressure on the side of the valve away from the source shall be relieved;
 - c. Line pressure shall be maintained on the side of the valve toward the source of pressure;
 - d. The Developer's utility subcontractor shall supply and operate the proper leak detection equipment, together with the Observer and personnel from the Water Department shall listen to each valve with a device that can detect a flow of water through the valve;
 - e. Each valve shall be checked working systematically back to the source of the pressure.

If there is doubt about the results of the above test on a particular valve, a water pressure test shall be conducted at a differential pressure of at least 100 psig across the valve, as directed by the Engineer.

8. HIGH-RATE FLOW TEST: High-rate flow test shall be performed on all newly installed waterlines only after satisfactory completion of the required hydrostatic and bacteriological tests. The Contractor shall provide advance notice conforming to the notification requirements listed above. It shall be of sufficient duration to clean the waterlines thoroughly. The Contractor shall make the necessary provisions for the proper disposal of the chlorinated water discharged during the test. Contractor personnel shall be responsible to perform the work required during the test except for operation of water system valves. The minimum size of the discharge pipe shall be 1/2 the diameter of the water main as shown on Standard Construction Details – HIGH-VOLUME FLUSHING APPARATUS – SWT-W-9.

NOTIFICATION: No connections shall be made to the existing Township system without prior approval and without three working days advance notice to the Township to allow for scheduling of Township observation personnel. This includes the operation of Township fire hydrants or any connections to mains or other points of connection.

TOWNSHIP REIMBURSEMENT: The costs for Township personnel to operate water system valves and attend hydrostatic, bacteriological and high-rate flow testing, or to perform similar duties associated with the Developer's project shall be borne by the Developer. The Township will invoice the Developer directly for these costs, payment for which shall be made within 15

days of the date of the invoice. In the absence of such reimbursement to the Township, improvements security releases will not be processed.

SINKHOLES: It is required that the Developer maintain all areas in a well-drained condition during the construction period so as to avoid pooling or ponding of water. If a sinkhole should develop during construction, the Developer shall immediately repair the sinkhole at its expense alone and in accordance with the following:

Upon detection of a sinkhole, the Developer or its Contractor shall notify the Township, contact its own geotechnical engineer who shall propose a repair solution and have that procedure reviewed by the Geotechnical Engineer. The Developer's geotechnical engineer and the Geotechnical Engineer shall monitor the repair in accordance with the reviewed procedure and upon completion of the repair and before any construction activity resumes in the area, the Developer's geotechnical engineer shall send a written report to the Township and to the Geotechnical Engineer that the sinkhole has been repaired in accordance with the reviewed procedure and that construction activities may continue.

SOUTH WHITEHALL TOWNSHIP AUTHORITY

TECHNICAL SPECIFICATIONS

SANITARY SEWERS AND APPURTENANCES

GENERAL: All materials and construction methods used in the construction of sanitary sewers and appurtenances shall meet the requirements as set forth in Pennsylvania Department of Transportation (PENNDOT) Specifications, Publication 408 except as specifically modified by the requirements herein, and except that the use of any type of slag, lightweight aggregate, or crushed concrete material is prohibited.

Materials

PIPE FOR GRAVITY SEWERS: All gravity sanitary sewers shall be:

1. Ductile iron pipe, Class 50 metal thickness; or
2. Polyvinyl chloride pipe (PVC) for 15-inch diameter or smaller pipe only;
3. Other material, as reviewed by the Engineer/Township.

All PVC pipe to be installed for gravity sewers less than 15 feet deep shall conform to ASTM D3034, SDR-35, and for sewers 15 feet or greater in depth shall conform to AWWA C900.

PIPE FOR PRESSURE SEWERS: All pressure sewers shall be material as reviewed by the Engineer/Township.

PIPE JOINTS: All ductile iron pipe joints shall be of the push-on type and shall conform to ANSI A 21.11 (current issue). All PVC pipe joints shall be of an integral bell design with a rubber gasketed joint which conforms to ASTM D 3212 - Joints for Drain and Sewer Plastic Pipes Using Flexible Elastomeric Seals - and ASTM F 477 - Elastomeric Seals (Gaskets) for Joining Plastic Pipe.

MANHOLES: Manholes shall be constructed of precast concrete sections, including grade rings, eccentric cones, riser sections and/or flat slab top sections conforming to ASTM C 478 Standard Specifications for Precast Reinforced Concrete Manhole Sections. Manhole bases shall be cast-in-place. Precast concrete bases may be permitted subject to the approval of shop drawings for the manholes by the Engineer/Township. In general, after tamping the excavated area, a leveling course of nine inches of compacted PENNDOT No. 2A stone, shall extend to the walls of the excavation beneath the precast manhole base. If the installation of the precast bases does not meet the approval of the Engineer/Township, further use will be prohibited.

MANHOLE JOINTS: Joints in precast concrete manhole sections shall be sealed with a mastic material (such as Rub-R-Nek). The material shall have a minimum cross-section one inch by one and one-half inches or one and one-half inches diameter. A double ring of mastic shall be used so that a continuous ring of mastic is forced from the joint on both the inside and outside manhole surfaces.

Where PVC sewer pipes connect to manholes the joints shall be made with resilient connections which meet the requirements of ASTM C-923 Standard Specifications for Resilient Connectors between Reinforced Concrete Manhole Structures and Pipes.

STEPS: All manholes shall be provided with steps. Steps shall conform to PENNDOT Specifications, Publication 408, Section 605.

MANHOLE FRAMES AND COVERS: Standard manhole castings shall be as shown on Standard Construction Details - PRECAST CONCRETE PIPE MANHOLE – SWT-S-4 or if required by the Township, HAMILTON KENT INC LIFESPAN 30” DIA. ASSEMBLY WITH COMPOSITE COVER – SWT-S-5.

All castings shall be true to form and dimensions, and shall be free from inclusions of foreign material, casting faults, injurious blow holes, cracks, sponginess, and other defects rendering them unsuitable. The finished frame and cover or grate shall have the bearing surfaces machined or ground so that there will be no variations that will permit rocking or rattling, and the diameter of the cover or grate shall be such as to fit the frame without wedging.

PUMP AND METER STATIONS: Detailed plans, design calculations, and specifications for all pumping and metering stations shall be submitted for review by the Engineer/Township. The Developer shall arrange with the manufacturer to provide the services of a factory-trained representative to perform the initial start-up of the station and to instruct the operating personnel in the operation and maintenance of the station. In addition, three copies of a complete operating and maintenance manual shall be provided to the Engineer before the station will be accepted by the Township. The station shall be designed and constructed so as to be controlled and monitored by the Township’s S.C.A.D.A. System. All programming and connection costs are to be borne by the Developer.

CONCRETE: All concrete required for channels, drop connections, etc. shall conform to the requirements of Pennsylvania Department of Transportation (PENNDOT) Specifications, Publication 408, Section 704, Class A concrete minimum.

Construction

EQUIPMENT: The Contractor shall provide equipment to handle the pipe in unloading and placing in its final position, without damage to the pipe.

The Contractor shall provide mechanical tampers and pneumatic tampers sufficient to obtain the compaction of the pipe bedding and backfill as specified.

Use of the Hydra-Hammer or impact type equipment similar to the Hydra-Hammer will not be permitted for compacting backfilled trenches.

EXCAVATION:

1. The Contractor shall perform all common excavation to the depth necessary as shown on the grade cut sheets reviewed by the Engineer;
2. The Contractor shall do all rock excavation to the depth required for common excavation plus at least eight inches below the bottom of the pipe bedding.

When rock or non-cushioning material is encountered in trench excavation, a cushion at least eight inches thick shall be placed between the rock and the bottom of the pipe bedding. The cushion shall consist of clean sand, equivalent granular material meeting the requirements of AASHTO No. 10 aggregate, or PENNDOT No. 2A stone. The bottom of the trench shall be excavated to a horizontal section as far as practicable.

Blasting may be considered only when proper precautions are taken for the safety of all persons, the work, and the property. All damage done to the work or property shall be repaired at the Developer's expense. All operations of the Developer in connection with the transportation, storage, and use of explosives shall conform to all federal, state and local regulations, explosive manufacturers' instructions, with applicable approved permits to be submitted to the authority having jurisdiction for review. Any review given, however, will not relieve the Developer of its responsibility in blasting operations.

Blasting shall be done only after obtaining necessary permits from state, local agencies, and Township Fire Inspector as applicable, and notifying the Township prior to each day of blasting;

3. Should unstable soil be encountered or should the Engineer deem it necessary to excavate to a depth below the grade shown on the Plans to secure a good foundation, the Contractor shall remove the unstable soil for the full width of the trench and replace it with PENNDOT No. 2A stone, as reviewed by the Engineer. The pipe bedding, shall be constructed on top of the PENNDOT No. 2A stone. The Engineer shall determine the depth of removal of unstable soil and the amount of backfill necessary. The backfill shall be thoroughly compacted and shaped to form the bed for the pipe;
4. Excavated material not required or acceptable for backfill shall be legally disposed of by the Contractor. Common excavation shall not be carried below the required depth. When this is done, the trench shall be backfilled with material reviewed by the Engineer and compacted to 95% for cohesive material and 100% for non-cohesive material of the Standard Proctor Density (AASHTO T 99 - Method C);
5. Where the bottom of the trench is found to be an inadequate foundation for the pipe and cannot be stabilized by the above methods, a concrete pad or cradle of sufficient size shall be constructed as determined by the Geotechnical Engineer;

6. The minimum width of the trench at the top of the pipe when placed shall be at least equal to the outside diameter of the pipe plus 12 inches on each side of the pipe. The trench shall be excavated accurately to the established line so that at least a 12-inch space will exist between the side of the trench and the side of the pipe. The maximum allowable width of trench shall not exceed 24 inches on each side of the pipe when placed;
7. The sides of trenches shall be vertical, for a minimum distance of four feet above the top of pipe. These requirements are for the stability of the trench and not to be confused with the safety issues of the trench. The Contractor shall perform such vee-ing, trench bracing, sheathing, or shoring necessary to perform and protect the excavation and as required for safety and to conform to governing laws. Unless otherwise provided, bracing, sheathing, or shoring shall be removed by the Contractor as backfill progresses in strict accordance with all safety procedures and to conform to all governing laws;
8. In the absence of more stringent limitations specifically defined herein or imposed by the Engineer, Township, or any other regulatory agency, the length of open trench shall be limited to 50 feet in advance of where pipe has been laid and 100 feet in total at any single location. Any open trenches shall be completely backfilled. Open trenches may be covered with steel plates only as reviewed by the Township on a case-by-case basis. All construction equipment shall be removed from within rights-of-way of existing public roadways at the end of each work day and immediately upon the temporary or permanent discontinuance of work.

BEDDING: Unless otherwise directed by the Engineer/Township, all pipe to be installed, including that which is laid on an eight inch cushion in areas of rock excavation, shall bear the full length on firm, flat compacted PENNDOT No. 2A stone bedding which is properly shaped to receive the pipe configuration at the joints. The bedding and initial backfill around the pipe shall be placed as follows:

1. For ductile iron pipe - minimum compacted thickness of four inches beneath the pipe;
2. For PVC pipe - when compacted the granular bedding shall extend from a minimum of four inches beneath the pipe to a minimum of 12 inches over top of the pipe.

Wherever the Geotechnical Engineer may deem it necessary, the pipe shall be laid on a concrete pad or cradle of sufficient size to span areas of unsatisfactory bearing.

LAYING AND INSTALLING PIPE: Pipe shall be laid to true alignment and regular grade. Before pipe is laid, all dirt shall be removed from inside the pipe and all lumps, blisters, dirt, oil, grease and moisture shall be removed from inside and outside the ends. After pipe is laid, care shall be taken to prevent the entrance of dirt or water from the trench. Every open end of a pipe or fitting shall be plugged before leaving the work for the day or before backfilling the trench. Plugs shall be on the site before the Contractor commences construction of the pipe line.

Installation methods for PVC pipe shall be in accordance with Uni-Bell UNI-B-5, Recommended Practice for the Installation of PVC Pipe and the Uni-Bell Plastic Pipe Association Handbook of PVC Pipe.

Cutting of pipe for closure pieces, or other reasons, shall be done in a neat and workmanlike manner by a method which will not damage the pipe. All such cutting of pipe shall be done in conformance with the manufacturer's recommendations.

The Engineer/Township may inspect all pipe before it is laid, and reject any section that is damaged by handling or is found to be defective to a degree which will materially affect the function and service of the pipe.

Pipe shall not be laid on frozen ground. Pipe which is not true in alignment, or which shows any settlement after laying, shall be taken up and re-laid.

The Contractor shall provide, as may be necessary, for the temporary diversion of stream flow in order to permit the installation of the pipe under dry conditions.

DEWATERING: Any water which collects in an excavation shall be removed by the Contractor before proceeding with the construction of the pipe line or structures.

LINE AND GRADE: The location (line) and/or grade of all sewers and pipe lines to be constructed shall be established by means of offset stakes, pins or other survey marks. When the Contractor uses a laser to obtain line and grade for laying the pipe, periodic checks shall be made by the Contractor from grade stakes. The first grade stake shall be furnished at 25 feet and at intervals not greater than 100 feet thereafter. When the Observer checks for vertical and/or horizontal alignment of the pipe, the Contractor shall assist him. Grade cut sheets shall be prepared by the Developer's Engineer and submitted to the Engineer for review a minimum of three working days prior to construction.

A minimum horizontal separation of ten feet and a minimum vertical separation of 18 inches shall be maintained between waterlines and sanitary or storm sewers in accordance with Pennsylvania Department of Environmental Protection Public Water Supply Manual, Part II, Community System Design Standards, Chapter 8, Section 8.7 inclusive, or latest version of the governing regulations. When conflicts occur with existing facilities and the separations are less than mentioned above, the corrective methods shall be reviewed by the Engineer/Township.

MANHOLES: Manholes shall be constructed to the requirements of PENNDOT Specifications, Publication 408, Section 605 and Section 714; the latest details of the PENNDOT Standards for Roadway Construction; these Specifications and the Standard Construction Details. All manholes which are less than seven feet from top of manhole to invert shall be constructed with "flat slab" top sections in lieu of the standard conical-shaped top sections.

When PVC pipe connects into a manhole, a water stop gasket produced from elastomeric material shall be used to prevent leakage while allowing longitudinal pipe expansion. This gasket shall be approved by the Engineer/Township. Grout shall be placed around the gasket and shall be of a type that expands, rather than shrinks, upon curing.

The cast-in-place base slab shall consist of reinforced Class A concrete (minimum) mixed, prepared, and placed in accordance with the requirements of PENNDOT Specifications, Publication 408. All manholes shall have flow channels built to the correct elevation, and shall be finished to cause the least possible resistance to flow. The flow channel may be formed directly in the concrete of the manhole base, or be constructed by laying half sections of pipe through the manhole and casting the concrete bench around the pipe. The base slab shall be a minimum of 12 inches thick below the invert.

To provide for future adjustment of the manholes, grade rings shall be used for a minimum height of 4 inches and a maximum height of 12 inches between the top precast section and the manhole frame. When necessary, brick can be used for final slope adjustment with concurrence of Engineer/Township.

Unless otherwise directed by the Engineer/Township, all invert elevation differences through manholes shall be less than 0.5 feet or greater than 3.0 feet. Drop pipes shall be installed for all sewers entering the manhole at elevations 3.0 feet or more above the manhole invert. The drop pipe and fittings shall be sewer pipe of the same material, type and class as that used for the collector system and shall be completely encased in a minimum of six inches of concrete. The concrete encasement shall conform to requirements of PENNDOT Specifications, Publication 408, for Class A concrete (minimum). The drop manhole shall be constructed in accordance with the Standard Construction Details.

All connections of new sanitary pipe to existing manholes shall be performed with a coring machine, unless otherwise approved by the Engineer/Township. The Contractor shall be required to obtain a "Confined Space Entry Permit" from the Township's Public Works Department prior to commencing work within the manhole.

INSTALLATION OF STEPS: The steps shall be installed as indicated on the Plans, or as directed by the Engineer. When the steps are to be set in concrete they shall be placed and secured in position before the concrete is poured. The steps shall not be disturbed or used until the concrete or mortar has hardened for at least seven days. After this period has elapsed, the steps shall be cleaned and painted, unless they have been galvanized, or coated satisfactorily.

When steps are required with precast concrete pipe structures, they shall be cast into the sides of the pipe at the time the pipe sections are manufactured, or set in place after the structure is erected by drilling holes in the concrete and cementing the steps in place.

Typical step configuration shall be in accordance with PENNDOT, Standards for Roadway Construction, detail for STANDARD MANHOLES, PRECAST MANHOLES & MANHOLE STEPS, RC-39M.

FITTINGS AND SERVICE LATERALS: The Contractor shall lay six inch "Y" branches for the purpose of making service lateral connections at each lot shown on the subdivision plan, and elsewhere if so directed by the Engineer/Township or Developer. "Y" branches shall be laid at an angle with the horizontal compatible with a lateral slope of 1/4 inch per foot, and have their ends plugged with an approved stopper.

Service laterals from sewer to property line, or to the point designated by the Engineer/Township, shall be laid by the Contractor, when so ordered by the Engineer/Township. Service laterals shall be of sufficient depth to serve basements unless otherwise ordered by the Engineer/Township. Service laterals shall have their ends plugged with an approved stopper.

The Contractor is cautioned that the sewer is to be tested by a leakage test as described elsewhere in these Specifications, and that the method used to secure the plugs in the branches and laterals must be such that the plugs will withstand the internal pressure of the test.

In general, specifications regarding materials, workmanship and watertight construction for fittings and service laterals shall be the same as those for main line sewers.

The Contractor shall mark the location of the plugged end of each lateral by placing a two lb./ft. steel channel, bar, or post, painted green. It shall be placed at the end of the pipe so that it extends from the pipe invert to four feet above the surface of the ground. The Contractor shall also provide the Engineer/Township with a record of stations and offsets, measured from the preceding manhole and centerline of sewer, for the end of each service lateral.

Cleanouts shall not be located in the Township right-of-way.

BACKFILLING: Backfilling of trenches for pipes shall be accomplished in accordance with these specifications. All trenches and excavations shall be backfilled promptly after the pipes are installed. Method of backfilling shall be as follows:

1. Within State Highway Right-of-Way: Backfilling shall be done in accordance with requirements of the State Highway Occupancy Permit;
2. Within existing streets, the backfill shall consist of:
 - a. A proper bedding of granular material properly formed to fully support the entire length of pipe;
 - b. PENNDOT No. 2A stone for initial backfill of sides and top of the pipe to eight inches below the existing subgrade;
 - c. Where required by the Geotechnical Engineer/Township, eight inches of clay placed and compacted to seal the trench at the subgrade elevation;
 - d. In lieu of b. and c. above and with written approval from the Township, "flowable fill"; i.e., "Controlled Low Strength Material" (CLSM), with late-age strength of 80 to 100 psi may be placed to existing subgrade elevation. The

120-day settlement period (as referenced below) is replaced by the time required to reach late-age strength;

- e. New base and surface courses at least equivalent to the material of the existing roadway, as determined by the Engineer;
 - f. When excavation of an existing Township street is necessary, it shall be done in accordance with requirements of the Township; i.e., the Street Excavation and Occupancy Permit.
3. In all other areas (including but not limited to proposed streets) the backfill shall consist of:
- a. A proper bedding of granular material properly formed to fully support the entire length of pipe;
 - b. Clean clay-like material or PENNDOT No. 2A stone for initial backfill of the sides and for 12 inches above the pipe. For PVC pipe, only PENNDOT No. 2A shall be used to 12 inches above the pipe, which envelope shall be maintained throughout the construction period and shall not extend into subbase materials for roadways;
 - c. Approved material free from organic matter, large or frozen lumps or stones over ten inches in their largest dimensions. Stones which are used in backfilling shall be so distributed through the mass that all interstices are filled with fine material.

The material shall be moistened or dried, if necessary, to obtain the required compaction. Backfill material shall be reviewed by the Engineer. The use of slag, lightweight aggregate, or crushed concrete in any form for bedding or backfill is prohibited. Special care shall be taken in placing the backfill. Particular care shall be used to obtain thorough compaction under the haunches and along the sides to the top of the pipe.

All backfill shall be placed in loose layers not exceeding six inches in depth under and around the pipe, and not exceeding eight inch lifts over the pipe. Successive layers shall be added and thoroughly compacted by mechanical and pneumatic tampers until the trench is completely filled to the elevation as directed. Backfilling shall be done in such a manner as to avoid injurious top or side pressures on the pipe.

Underground warning tape shall be installed a minimum of two feet above any pipe in the backfill of any mainline or lateral trench. Tape shall be alkali resistant, 4 mils polyethylene, 4 inches minimum width, continuously printed with name or symbol of utility buried below, color coded as follows:

Red: Electric.

Yellow: Gas, oil, and dangerous materials.

Orange: Telephone, cable TV, and other communications.

Blue: Water systems.

Green: Sewerage systems.

Where plastic pipe water or sewer pipe is used the tape shall be appropriately colored and able to conduct a signal generated by a locating device.

Backfill shall be compacted to a density of not less than 95% of maximum density for cohesive and 100% for non-cohesive material. The maximum density is the maximum dry weight density in pounds per cubic foot as determined by the Standard Proctor Density (AASHTO T 99 - Method C).

All backfilled trenches shall be allowed to settle for at least 120 days before the permanent base course or pavement may be constructed. Where less than 120 days of settlement time is anticipated and permitted by the Engineer, all trench backfill shall be PENNDOT No. 2A stone, compacted and when required by the Geotechnical Engineer/Township, capped with eight inches of clay at subgrade elevation, wherever permanent base course and pavement is to be constructed. In such cases, the delay time until paving is permitted is to be determined by the Engineer/Township.

LEVELING COURSE: A leveling course of precast concrete adjustment units shall be provided at all manholes and inlets to set each casting at final grade. Brick is to be used for slope adjustments only, and the inside and outside surfaces of the masonry leveling course shall be neatly plastered with mortar to a minimum thickness on one-half inch.

LEAKAGE TEST FOR GRAVITY SEWERS: The Contractor shall clean debris of whatever nature from the pipes and shall repair all apparent leaks, after which the loss of water from the sewer or the infiltration of water into the sewer in each test section shall not exceed 100 gallons per inch of inside pipe diameter per mile of sewer per 24 hours for vitrified clay pipe and 50 gallons per inch of inside pipe diameter per mile of sewer per 24 hours for polyvinyl chloride (PVC) and ductile iron pipe, as determined by the following leakage tests, to be conducted by, and at the expense of, the Contractor.

Each pipe section between manholes, or longer sections if permitted by the Engineer/Township, shall be tested by either method 1 or 2:

1. Each section shall be tested by a low pressure air test; or
2. Each section shall be tested by an Exfiltration Test.

The Section to be tested shall be filled with water under a head maintained at four feet above the top of the pipe at the highest point or four feet above the prevailing ground water level, whichever is higher, for a period of 30 minutes, after which period the leakage test shall be conducted, under the same head of water, for an additional 30 minutes. The test shall be repeated until satisfactory.

The Contractor is cautioned that the loosening of plugs in branch fittings and laterals will not be grounds for waiving the leakage test. In such instances the trench shall be excavated and the plugs replaced, after which the leakage test will be repeated.

Polyvinyl Chloride Pipe shall be tested in accordance with the following procedure:

- a. Clean the pipe to be tested;
- b. Plug all pipe outlets with suitably braced plugs;
- c. Add air slowly to the test section of the pipe until the internal air pressure is 4.0 pounds per square inch gauge (psig);
- d. After the pressure decreases to 3.5 psig, the time required for the pressure to drop one-half psig from 3.5 psig to 3.0 psig shall be measured. The sewer line will have passed the test if the measured time is greater than the minimum pressure holding time recommended by the Uni-Bell Plastic Pipe Association in the "Recommended Practice for Low Pressure Air Testing of Installed Sewer Pipe" for the respective diameter of pipe.

SPECIFICATION-MINIMUM HOLDING TIME REQUIRED FOR A 0.5 PSIG PRESSURE
DROP
FOR SIZE AND LENGTH OF PIPE INDICATED FOR Q = 0.0015 CFS

Pipe Dia. (in.)	Min. Time (min: sec.)	for Min. Time (ft.)	for Longer Length (sec.)	100 ft.	150 ft.	200 ft.	250 ft.	300 ft.	350 ft.
4	1:53	597	.190L	1:53	1:53	1:53	1:53	1:53	1:53
6	2:50	398	.427L	2:50	2:50	2:50	2:50	2:50	2:50
8	3:47	298	.760L	3:47	3:47	3:47	3:47	3:48	4:26
10	4:43	239	1.187L	4:43	4:43	4:43	4:57	5:56	6:55
12	5:40	199	1.709L	5:40	5:40	5:42	7:08	8:33	9:58
15	7:05	159	2.671L	7:05	7:05	8:54	11:08	13:21	15:35

Ductile iron pipe used in a gravity system shall be pressure tested in accordance with the same procedure as outlined for polyvinyl chloride pipe.

The gauge used for measurements in the above tests shall be graduated in increments no greater than 0.25 psig.

For any of the above procedures, if the prevailing groundwater level is above the top of the pipe to be tested, the required test pressure will be increased by an amount equal to the groundwater pressure exerted on the pipe;

Under certain circumstances where there is high ground water, the Engineer/Township may require an Infiltration Test for some or all sections of the sewers in the contract. This test shall meet the leakage test requirements previously cited, and shall be used only where directed by the Engineer/Township. The Infiltration Test shall consist of segregating that portion of the line to be tested and measuring the amount of infiltration by a method approved by the Engineer/Township, such as with a V-notch weir or a timed overflow.

LEAKAGE TEST FOR MANHOLES: Each manhole shall be tested by a vacuum test or an exfiltration test as outlined below:

VACUUM TEST: All pipes entering the manhole to be tested shall be plugged and the vacuum testing ring shall be installed on the manhole frame so that all joints, including the joint between the manhole frame and the leveling courses are tested. A vacuum equivalent to a minimum of 10 inches of mercury shall be drawn on the manhole and all test valves shall be closed. The manhole will have passed the vacuum test if the vacuum loss is no more than the equivalent of one inch of mercury within 60 seconds for a 48-inch diameter manhole, within 75 seconds for 60-inch diameter manhole or within 90 seconds for a 72-inch diameter manhole; or

EXFILTRATION TEST: All pipes entering the manhole to be tested shall be plugged and the manhole shall be filled with water to within three inches of the proposed top elevation of the manhole casting. The test shall be placed on the manhole for a period of 30 minutes after which the drop in water level shall be measured. The manhole will have passed the exfiltration test if the drop in water level does not exceed 1/4 inch.

Any manhole that is adjusted, damaged or in any way altered after passing the leakage test shall be retested and/or repaired to the satisfaction of the Engineer/Township.

CAUTION FOR PRESSURE TESTING. The following caution is applicable to all pressure testing on the project.

CAUTION. When piping systems are pressure tested, it is extremely important and essential that all plugs including test plugs and all pipe joints are installed and restrained in such a way that blowouts are prevented. It must be realized that sudden expulsion of a poorly installed plug or section of pipe or of a test plug which is partially deflated before the pipe pressure is released can be very dangerous. For this reason it is recommended that every plug and pipe joint be positively braced or otherwise restrained during pressure testing and that no one be allowed in the vicinity of an exposed plug or pipe so long as pressure is maintained in the line.

DEFLECTION TEST: Deflection testing shall be performed on all portions of the main line PVC sewer. Laterals will not be subjected to this test but shall have been constructed before this test is conducted. This test shall be performed in sections between manholes not less than 30 days or not more than 12 months following backfill of the trench.

Deflection testing shall be performed in accordance with the procedure outlined below and any section of the PVC sewer system not meeting the minimum requirements for deflection shall be excavated, repaired, and retested to the Engineer's/Township's satisfaction.

The maximum allowable deflection (reduction in vertical inside diameter) for all installed PVC sewer pipe, meeting the SDR 35 and minimum wall thickness requirements shall not exceed five percent of the original internal diameter of the pipe.

Deflection testing shall be performed with a "go, no-go" mandrel which is sized to such dimensions that it will not "go" when encountering deflection greater than permissible. The test mandrel shall have an outside diameter equal to 95% of the base inside diameter of the pipe being tested and shall be supplied at the Contractor's expense. All tests shall be performed without mechanical pulling devices.

VIDEO INSPECTION: The Township may video inspect or direct the Developer to video inspect at its expense, the installed pipe so as to verify alignment, joint seals, etc. This inspection will be performed prior to acceptance. Any defects discovered thereby are to be corrected at the Contractor's expense.

NOTIFICATION: No connections shall be made to existing Township systems without a valid Pennsylvania Department of Environmental Protection sewer extension permit and without prior approval and three working days advance notice to the Township to allow for scheduling of Township observation personnel. Connections to the Township sanitary sewerage system require a "Confined Space Entry Permit".

SINKHOLES: It is required that the Developer maintain all areas in a well-drained condition during the construction period so as to avoid pooling or ponding of water. If a sinkhole should develop during construction, the Developer shall immediately repair the sinkhole at its expense alone and in accordance with the following:

Upon detection of a sinkhole, the Developer or its Contractor shall notify the Township, contact its own geotechnical engineer who shall propose a repair solution and have that procedure reviewed by the Geotechnical Engineer. The Developer's geotechnical engineer and the Geotechnical Engineer shall monitor the repair in accordance with the reviewed procedure and upon completion of the repair and before any construction activity resumes in the area, the Developer's geotechnical engineer shall send a written report to the Township and to the Geotechnical Engineer that the sinkhole has been repaired in accordance with the reviewed procedure and that construction activities may continue.

SOUTH WHITEHALL TOWNSHIP

TECHNICAL SPECIFICATIONS

MISCELLANEOUS IMPROVEMENTS

CONDITION OF COMMON OPEN SPACES. All common open spaces to be dedicated to the Township shall be improved, if necessary, by the developer prior to acceptance of dedication by the Township, so that all of the following conditions are satisfied:

Topsoil. All common open spaces to be dedicated to the Township shall include a minimum of four (4) inches or as otherwise designated on the Plans of good quality topsoil conforming to the requirements of PENNDOT Specifications, Publication 408 Section 802 unless otherwise approved by the Board of Commissioners.

Lawn Areas. Unless wooded, all common open spaces shall be in lawn prior to dedication, and shall be improved in accordance with the following requirements:

Materials:

Seed Mixture.

<u>Seed</u>	<u>% by weight</u>
Kentucky Bluegrass	25.00%
Perennial Ryegrass	40.00%
Tall Fescue	25.00%
Annual Ryegrass	9.00%
Other Crop Seed	0.20%
Inert Matter	0.70%
Weed Seed	0.10%

All seed shall be delivered in the original packages, unopened, which shall bear a guaranteed analysis (Blue Tag Certified) by the vendor and shall be approved by the Township.

Fertilizers.

	<u>Nitrogen</u>	<u>Phosphorus</u>	<u>Potash</u>
Starter Fertilizer for Lawns	18	24	12

Fertilizer shall be a composite and shall bear manufacturer's guaranteed statement of analysis and shall have at least 25% by weight of the nitrogen content of the fertilizer derived from organic material. Fertilizer distribution may be hopper or drill type.

Ground Limestone. Shall be raw, ground agricultural limestone containing more than 90% calcium carbonates, 50% to pass 100 mesh sieve, 90% to pass 20 mesh sieve.

Mulch. Shall be clean oat straw free from mature seed bearing stalks or roots of prohibited or noxious weeds as defined by the Pennsylvania Seed Act 1947 or wood cellulose fiber processed to contain no growth or germination-inhibiting factors and dyed an appropriate color to facilitate visual metering of the application of the materials.

Tools and Equipment. Shall be hand tools, machinery and equipment normal to the trade. If a roller is used, it shall weigh not more than 100 pounds per foot of width.

Preparation. The site shall be graded as necessary to bring the finish grade to a true, smooth slope for areas which are to be seeded.

- Apply Type II Fertilizer at the rate of four (4) pounds of Nitrogen per 1,000 square feet.
- Apply ground limestone at the rate required by a soil analysis.
- Materials listed above shall be uniformly applied and thoroughly incorporated into the soil by rototilling or other approved method to a minimum depth of four (4) inches. The entire surface shall then be regraded and rolled.
- Any surface irregularities shall be corrected in order to prevent pocket or low area formation which will allow water to stand.
- York rake and clean the surface of all stones larger than one and one-half (1½) inches in diameter or any other substances which will interfere with turf development or subsequent mowing operations.

Seeding. The developer shall, at its own expense, seed or sod all areas inside the lands to be dedicated to the Township, and all areas outside the lands to be dedicated to the Township which have been disturbed by the work performed on lands to be deeded to the Township. Seeding shall be done in two separate operations. The second seeding shall be done immediately after the first and at right angles to the first seeding and lightly raked into the soil. Mulch seeded areas with straw at the rate of two (2) tons per acre. Take precautions to stabilize the mulch and to keep the area undisturbed until the grass is established. Apply wood cellulose as recommended by the manufacturer. Those areas around storm drainage structures or in steep drainage swales shall have sod installed with an approved sod and as directed to eliminate erosion.

Seeding Methods. Hydro-seeding with approved hydraulic seeding equipment may be used to sow seed, fertilizer, lime and wood cellulose fiber mulch in one operation.

Prepare the area then apply seed, limestone, fertilizer and wood cellulose fiber as indicated previously.

Repairs. Repair by filling with topsoil, tamping, re-fertilizing and reseeding areas where damage resulting from erosion, gullies, washouts or other causes is evident before acceptance of the area.

Maintenance. Maintain lawns by weeding, watering, mowing, and replanting as necessary until the third cutting, and longer if necessary to establish a uniform stand of specified grass determined acceptable by the Township. Make the first cutting when grass has reached the height of three (3) inches, cut to two-and-a-half (2½) inches. Scattered bare spots, smaller than one square foot, will be allowed up to one percent (1%) of the lawn areas. If seeded areas are not up to specified standards, the developer's responsibility for maintenance shall be extended until new grass is established. Reseeding shall conform in all respects to these specifications.

Fencing. Fence, as shown on Standard Construction Detail SWT-D-8, shall be installed around the perimeter of the common open space and/or community recreational facilities to be dedicated and/or the accesses thereto, in the discretion of the Township, unless waived by the Township for good cause shown.

SHADE TREES.

Species of Trees Permitted. Trees within street rights-of-way or tree easements shall be deciduous hardwood types of varieties (including hybrids thereof) indicated within the South Whitehall Township Shade Tree Policy, as established by the Board of commissioners from time to time, or other species approved by the shade Tree Commission.

Tree Specifications:

Trees shall be of nursery-stock quality, grown under the same climatic conditions as at the location of the development.

All planting shall be in conformance with industry-accepted nursery practice, and to the standards established by the Landscape and Shade Tree Commission.

Trees permitted shall be of symmetric growth, free of insect pests and disease.

The trunk diameter (caliper) measured at a height of six (6) inches above ground level shall be a minimum of 2 – 2½ inches. Trees shall have a single, straight stem for a minimum of four (4)-feet above ground level to the first lateral branches.

Depending on the particular species to be planted, the Landscape and Shade Tree Commission may modify the size requirements of trees.

Section C STANDARD CONSTRUCTION DETAILS

SOUTH WHITEHALL TOWNSHIP

AND

SOUTH WHITEHALL TOWNSHIP AUTHORITY

LEHIGH COUNTY, PENNSYLVANIA

STANDARD CONSTRUCTION DETAILS

MARCH 2017

PREPARED BY

THE PIDCOCK COMPANY

CIVIL ENGINEERING AND LAND PLANNING ARCHITECTURE LAND SURVEYING

OXFORD DRIVE AT FISH HATCHERY ROAD
ALLENTOWN, PENNSYLVANIA

SOUTH WHITEHALL TOWNSHIP

AND

SOUTH WHITEHALL TOWNSHIP AUTHORITY

LEHIGH COUNTY, PENNSYLVANIA

INDEX OF DETAILS

SWT NO.	TITLE	PLAN DATE OR LAST REVISION	SWT NO.	TITLE	PLAN DATE OR LAST REVISION
SWT-D-1	STANDARD PRECAST CONCRETE PIPE MANHOLE	MARCH 2017	SWT-S-1	TYPICAL SERVICE CONNECTION DEEP SEWER	MARCH 2017
SWT-D-2	SHALLOW PRECAST CONCRETE PIPE MANHOLE	MARCH 2017	SWT-S-2	TYPICAL SANITARY SERVICE CONNECTION	MARCH 2017
SWT-D-3	PRECAST CONCRETE, TYPE M INLET	MARCH 2017	SWT-S-3	PRECAST CONCRETE PIPE DROP MANHOLE	MARCH 2017
SWT-D-4	PRECAST CONCRETE, TYPE C INLET	MARCH 2017	SWT-S-4	STANDARD PRECAST CONCRETE MANHOLE	MARCH 2017
SWT-D-5	MANHOLE TO INLET CONVERSION	MARCH 2017	SWT-S-5	HAMILTON KENT INC. LIFESPAN 30" DIA. ASSEMBLY WITH COMPOSITE COVER	MARCH 2017
SWT-D-6	MODIFIED INLET	MARCH 2017			
SWT-D-7	REINFORCED CONCRETE LOW FLOW CHANNEL -- DETAIL DELETED	MARCH 2017			
SWT-D-8	DETENTION BASIN AND OPEN-SPACE FENCE	MARCH 2017	SWT-W-1	FIRE HYDRANT	MARCH 2017
			SWT-W-2	HORIZONTAL THRUST BLOCKS	MARCH 2017
			SWT-W-3	VERTICAL THRUST BLOCKS	MARCH 2017
SWT-G-1	STANDARD TRENCH	MARCH 2017	SWT-W-4	WATERLINE BLOW-OFF	MARCH 2017
			SWT-W-5	SERVICE CONNECTION	MARCH 2017
			SWT-W-6	VALVE AND VALVE BOX	MARCH 2017
SWT-R-1	TYPICAL ROADWAY CROSS SECTIONS	MARCH 2017	SWT-W-7	WATER METER/DOUBLE CHECK DETECTOR ASSEMBLY AND PIT	MARCH 2017
SWT-R-2	NON-STATE HIGHWAY PAVEMENT RESTORATION	MARCH 2017	SWT-W-8	CAMPUS WATER METER AND PIT	MARCH 2017
SWT-R-3	RESIDENTIAL SIDEWALK AND DRIVEWAY APRON	MARCH 2017	SWT-W-9	HIGH-VOLUME FLUSHING APPARATUS	MARCH 2017
SWT-R-4	NON-RESIDENTIAL SIDEWALK AND DRIVEWAY APRON	MARCH 2017	SWT-W-10	3/4" - 2" WATER METER ASSEMBLY	MARCH 2017
SWT-R-5	CONCRETE CURB	MARCH 2017	SWT-W-11	SAMPLING STATION	MARCH 2017
SWT-R-6	SIDEWALK AND CURB RAMP -- DETAIL DELETED	MARCH 2017			
SWT-R-7	BELGIAN BLOCK GRANITE CURB	MARCH 2017			
SWT-R-8	STANDARD CONCRETE MONUMENT	MARCH 2017			
SWT-REC-1	RECREATIONAL TRAIL				

NOTE:

THESE STANDARD CONSTRUCTION DETAILS TOGETHER WITH THE GENERAL PROVISIONS AND TECHNICAL SPECIFICATIONS CONSTITUTE THE STANDARD CONSTRUCTION DOCUMENTS FOR PUBLIC INTEREST IMPROVEMENTS INSTALLED AS PART OF SUBDIVISIONS/LAND DEVELOPMENTS WITHIN SOUTH WHITEHALL TOWNSHIP.

Drawing name: S:\Municipalities\Municipal Construction Documents\South Whitehall Township\SWT-WORKING DOCUMENTS\SWT-COVER-INDEX.dwg Printed: Mar 22, 2017 - 4:02pm

Drawing name: S:\Municipalities\Municipal Standard Construction Documents\South Whitehall Township\Working Documents\SWT-D-01.dwg Printed: Mar 22, 2017 4:02pm

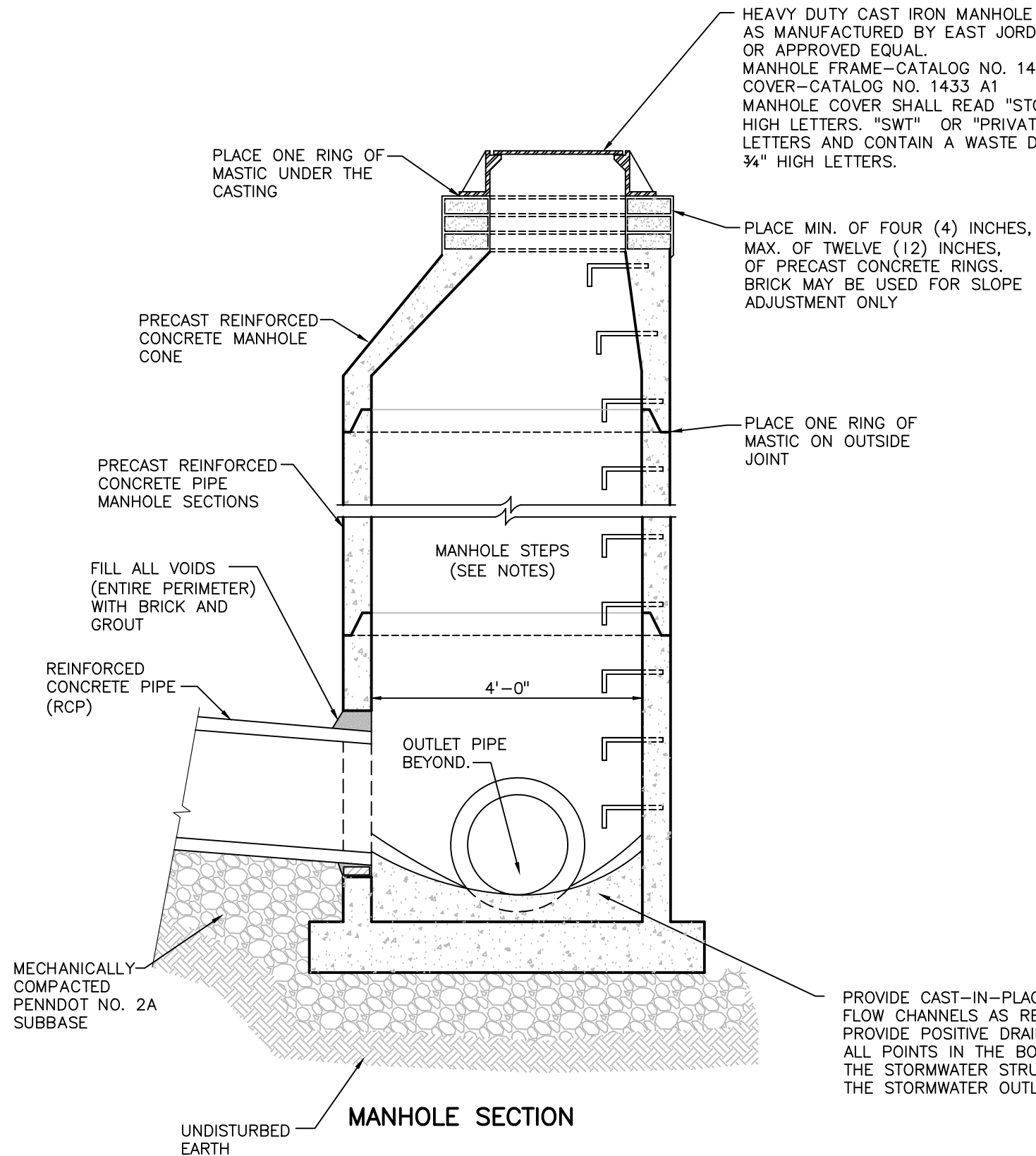

HEAVY DUTY CAST IRON MANHOLE FRAME AND COVER AS MANUFACTURED BY EAST JORDAN IRON WORKS, INC. OR APPROVED EQUAL.
 MANHOLE FRAME—CATALOG NO. 1433 Z2
 COVER—CATALOG NO. 1433 A1
 MANHOLE COVER SHALL READ "STORM" CAST IN 1½" HIGH LETTERS. "SWT" OR "PRIVATE" CAST IN 1½" HIGH LETTERS AND CONTAIN A WASTE DUMPING WARNING IN ¾" HIGH LETTERS.

PLACE ONE RING OF MASTIC UNDER THE CASTING

PLACE MIN. OF FOUR (4) INCHES, MAX. OF TWELVE (12) INCHES, OF PRECAST CONCRETE RINGS. BRICK MAY BE USED FOR SLOPE ADJUSTMENT ONLY

PRECAST REINFORCED CONCRETE MANHOLE CONE

PLACE ONE RING OF MASTIC ON OUTSIDE JOINT

PRECAST REINFORCED CONCRETE PIPE MANHOLE SECTIONS

MANHOLE STEPS (SEE NOTES)

FILL ALL VOIDS (ENTIRE PERIMETER) WITH BRICK AND GROUT

4'-0"

REINFORCED CONCRETE PIPE (RCP)

OUTLET PIPE BEYOND.

MECHANICALLY COMPACTED PENNDOT NO. 2A SUBBASE

PROVIDE CAST-IN-PLACE CONCRETE FLOW CHANNELS AS REQUIRED TO PROVIDE POSITIVE DRAINAGE FROM ALL POINTS IN THE BOTTOM OF THE STORMWATER STRUCTURE TO THE STORMWATER OUTLET PIPE

UNDISTURBED EARTH

MANHOLE SECTION

NOTES:

1. A 12" CAST-IN-PLACE, REINFORCED BASE MAY BE USED FOR A "DOGHOUSE" TYPE MANHOLE.
2. STEP DIMENSIONS AND CONFIGURATION SHALL BE IN ACCORDANCE WITH PENNDOT STANDARDS FOR ROADWAY CONSTRUCTION, CURRENT EDITION (PDT PUB #72M), RC-39M.
3. THE MANUFACTURER OF THE MANHOLES SHALL BE INCLUDED ON THE PENNDOT LIST OF APPROVED MANUFACTURERS OF PRECAST CONCRETE PRODUCTS (BULLETIN 15).
4. REFER TO PDT PUB #72M, RC-39M FOR ADDITIONAL REQUIREMENTS.
5. WHERE POSSIBLE, STEPS SHALL BE ORIENTED SUCH THAT ENTRY/EXIT WILL FACE THE GENERAL DIRECTION OF ONCOMING TRAFFIC.
6. MANHOLE FRAME AND COVER SHALL BE PLACED OUT OF VEHICULAR WHEEL PATH AS MUCH AS PRACTICAL.

STANDARD PRECAST CONCRETE PIPE MANHOLE
 (SHOWN WITH PRECAST BASE)
 NO SCALE

REVISIONS	SOUTH WHITEHALL TOWNSHIP STANDARD CONSTRUCTION DETAILS LEHIGH COUNTY, PENNSYLVANIA	
	STORM DRAINAGE STANDARD PRECAST CONCRETE PIPE MANHOLE	
	THE PIDCOCK COMPANY CIVIL ENGINEERING AND LAND PLANNING ARCHITECTURE LAND SURVEYING OXFORD DRIVE AT FISH HATCHERY ROAD ALLENTOWN, PENNSYLVANIA	
	DATE: MARCH 2017 CHKD BY: RJK SCALE: NO SCALE	SWT-D-1

Drawing name: S:\Municipalities\Municipal Standard Construction Documents\South Whitehall Township\Working Documents\SWT-D-02.dwg Printed: Mar 22, 2017 4:02pm

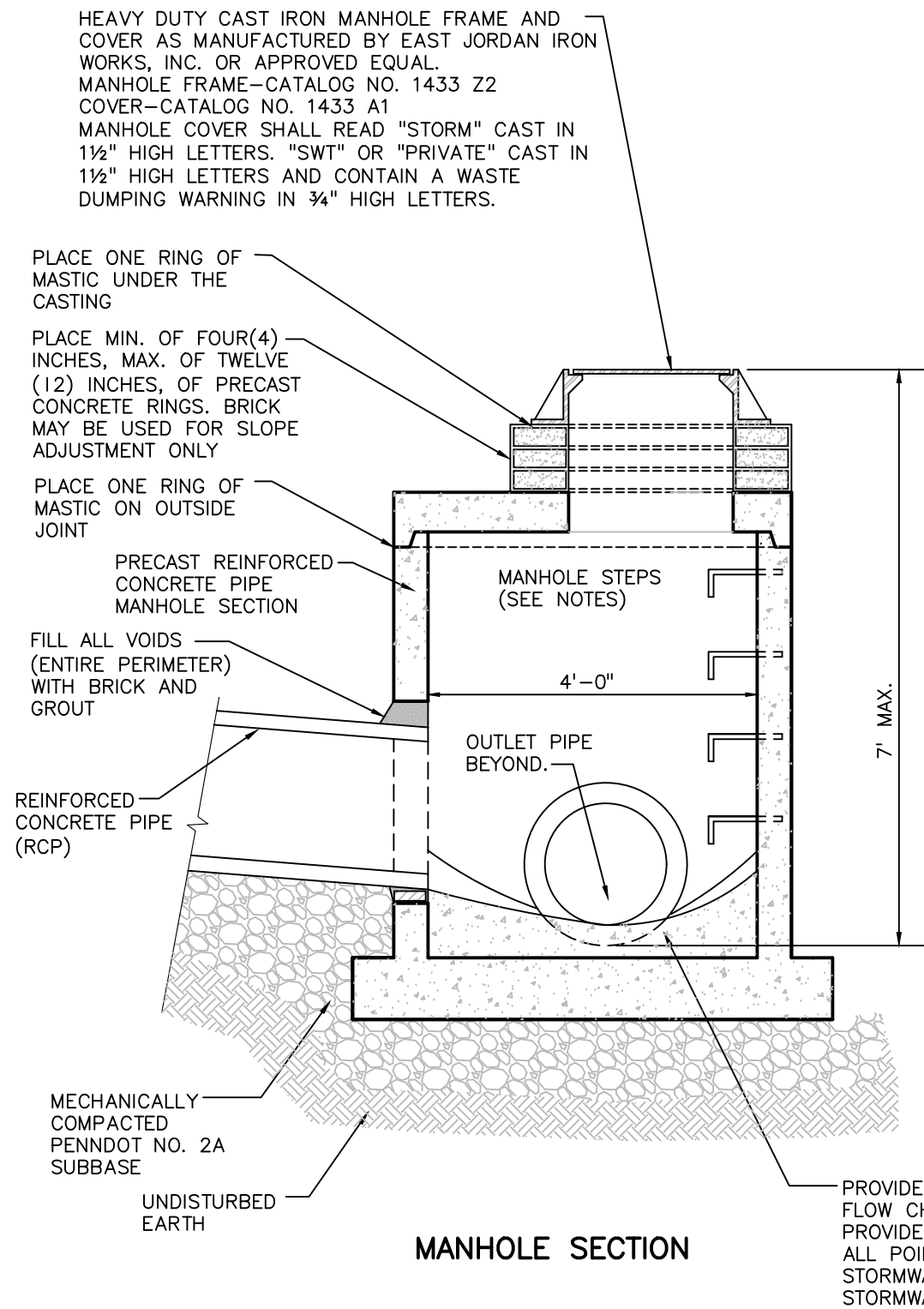

MANHOLE SECTION

SHALLOW PRECAST CONCRETE PIPE MANHOLE
 (SHOWN WITH PRECAST BASE)
 NO SCALE

NOTES:

1. A 12" CAST-IN-PLACE, REINFORCED BASE MAY BE USED FOR A "DOGHOUSE" TYPE MANHOLE.
2. STEP DIMENSIONS AND CONFIGURATION SHALL BE IN ACCORDANCE WITH PENNDOT STANDARDS FOR ROADWAY CONSTRUCTION, CURRENT EDITION (PDT PUB #72M), RC-39M.
3. THE MANUFACTURER OF THE MANHOLES SHALL BE INCLUDED ON THE PENNDOT LIST OF APPROVED MANUFACTURERS OF PRECAST CONCRETE PRODUCTS (BULLETIN 15).
4. REFER TO PDT PUB #72M, RC-39M FOR ADDITIONAL REQUIREMENTS.
5. WHERE POSSIBLE, STEPS SHALL BE ORIENTED SUCH THAT ENTRY/EXIT WILL FACE THE GENERAL DIRECTION OF ONCOMING TRAFFIC.
6. MANHOLE FRAME AND COVER SHALL BE PLACED OUT OF VEHICULAR WHEEL PATH AS MUCH AS PRACTICAL.

REVISIONS	SOUTH WHITEHALL TOWNSHIP STANDARD CONSTRUCTION DETAILS LEHIGH COUNTY, PENNSYLVANIA	
	STORM DRAINAGE SHALLOW PRECAST CONCRETE PIPE MANHOLE	
	THE PIDCOCK COMPANY CIVIL ENGINEERING AND LAND PLANNING ARCHITECTURE LAND SURVEYING OXFORD DRIVE AT FISH HATCHERY ROAD ALLENTOWN, PENNSYLVANIA	
	DATE: MARCH 2017 CHKD BY: RJG SCALE: NO SCALE	SWT-D-2

Drawing name: S:\Municipalities\Municipal Standard Construction Documents\South Whitehall Township\Working Documents\SWT-D-03.dwg Printed: Mar 22, 2017 4:02pm

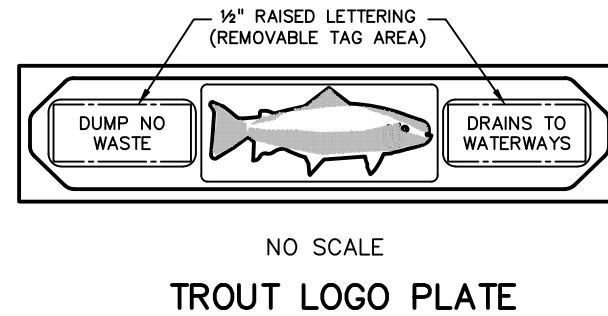
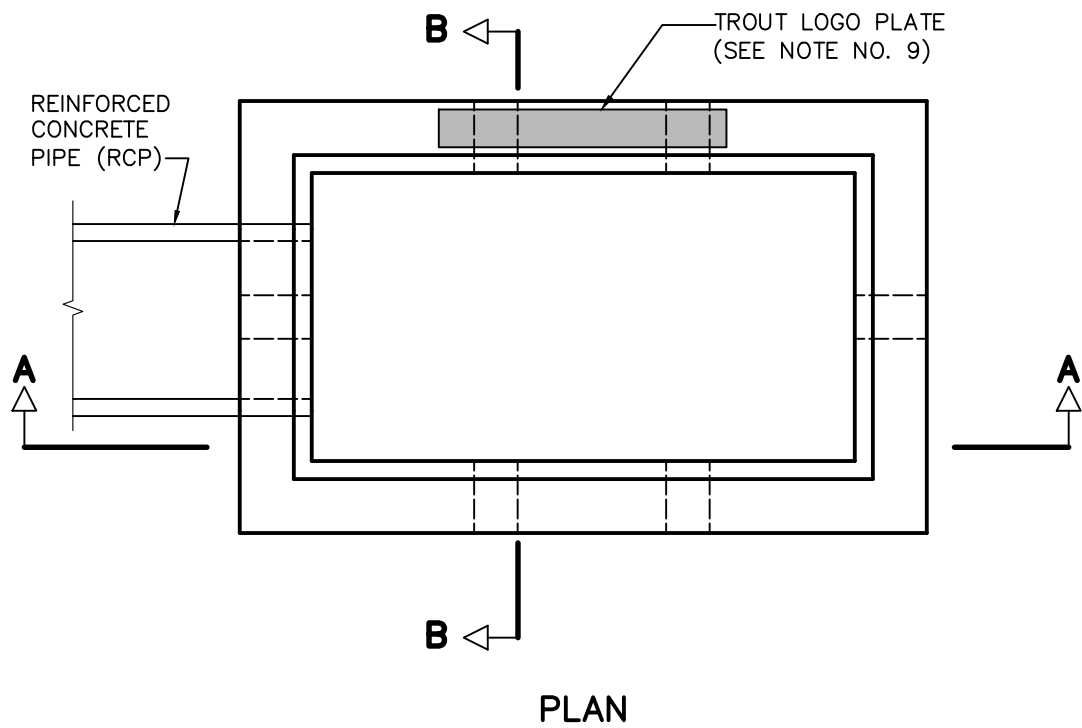

NOTES:

1. CONCRETE INLET AND TOP UNITS SHALL BE AS DETAILED IN PENNDOT STANDARDS FOR ROADWAY CONSTRUCTION, CURRENT EDITION (PDT PUB #72M) RC-45M, "INLETS, CONCRETE TOP UNITS CAST-IN-PLACE AND PRECAST".
2. PROVIDE A MINIMUM OF 4 INCHES AND MAXIMUM OF 8 INCHES VERTICALLY OF PRECAST CONCRETE COLLARS WITH THROUGH-WALL OPENINGS ADJACENT TO SUBGRADE TO SERVE AS WEEP HOLES.
3. ALL EXPOSED EDGES SHALL BE CHAMFERED 1"x1".
4. STEPS SHALL BE PROVIDED WHENEVER STRUCTURE EXCEEDS 4 FEET IN DEPTH.
5. STEP DIMENSIONS AND CONFIGURATION SHALL BE IN ACCORDANCE WITH PENNDOT STANDARDS FOR ROADWAY CONSTRUCTION, CURRENT EDITION (PDT PUB #72M), RC-39M.
6. PROVIDE STRUCTURAL STEEL GRATE - BICYCLE SAFE, AS DETAILED IN PENNDOT STANDARDS FOR ROADWAY CONSTRUCTION, CURRENT EDITION (PDT PUB #72M) RC-45M, "INLET GRATES".
7. THE BACKFILL AROUND THE WEEPHOLES SHALL NOT CONTAIN SCREENINGS; i.e., PLACE PENNDOT NO. 3 OR LARGER STONES AS REQUIRED BY ENGINEER, WITHOUT SCREENINGS TO ALLOW WATER TO ENTER WEEPHOLES. PLACE GEOTEXTILE FABRIC AROUND BACKFILL TO PREVENT MIGRATION OF SURROUNDING MATERIAL INTO VOIDS OF BACKFILL.
8. THE MANUFACTURER OF THE INLETS SHALL BE INCLUDED ON THE PENNDOT LIST OF APPROVED MANUFACTURERS OF PRECAST CONCRETE PRODUCTS (BULLETIN 15).
9. TOP UNITS MUST CONTAIN THE 24-INCH BY 3-INCH TROUT LOGO PLATE AND TAGS DISPLAYING A DUMPING WARNING AS MANUFACTURED BY EAST JORDAN IRON WORKS INC. (CATALOG NO. 7003PL1) TO BE READ FROM ROADWAY SIDE OF INLET.
10. REFER TO CURRENT EDITION, (PDT PUB #72M), RC-46M FOR ADDITIONAL INLET BOX REQUIREMENTS.

PLAN

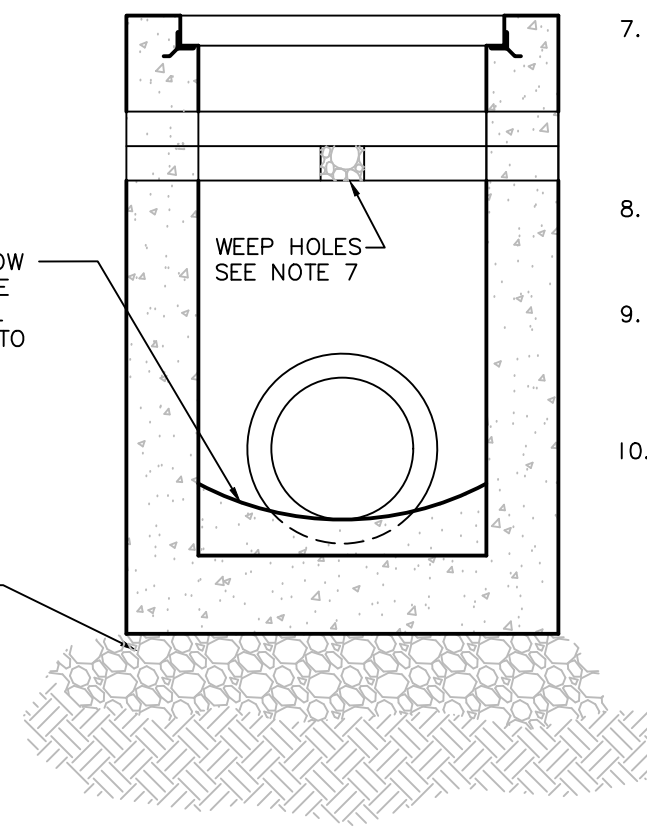
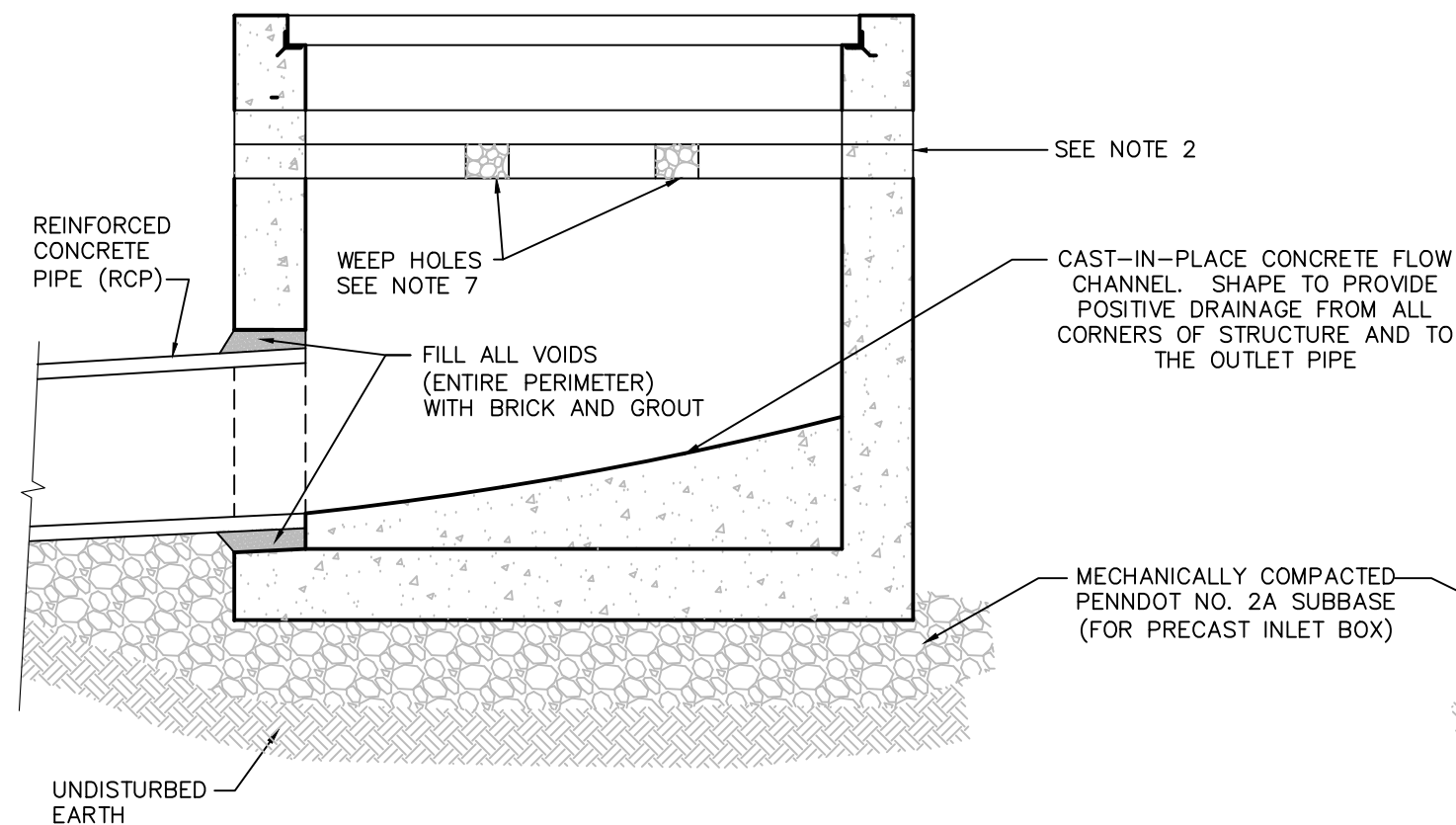

SECTION A-A

SECTION B-B

TYPE M INLET
NO SCALE

REVISIONS	SOUTH WHITEHALL TOWNSHIP STANDARD CONSTRUCTION DETAILS LEHIGH COUNTY, PENNSYLVANIA	
	STORM DRAINAGE PRECAST CONCRETE TYPE M INLET	
	THE PIDCOCK COMPANY <small>CIVIL ENGINEERING AND LAND PLANNING ARCHITECTURE LAND SURVEYING</small>	
	<small>DATE: MARCH 2017</small>	<small>CHKD BY: RJG</small>
	<small>SCALE: NO SCALE</small>	SWT-D-3

Drawing name: S:\Municipalities\Municipal Standard Construction Documents\South Whitehall Township\SWT-WORKING DOCUMENTS\SWT-D-04.dwg Printed: Mar 22, 2017 4:02pm

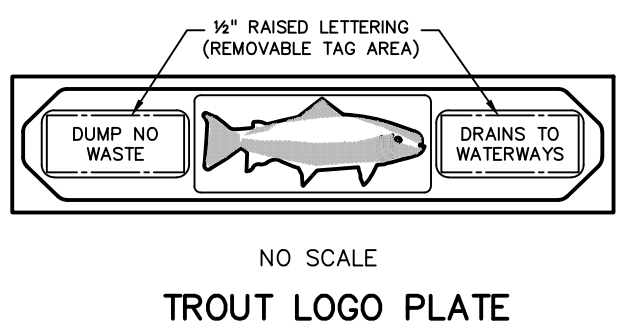
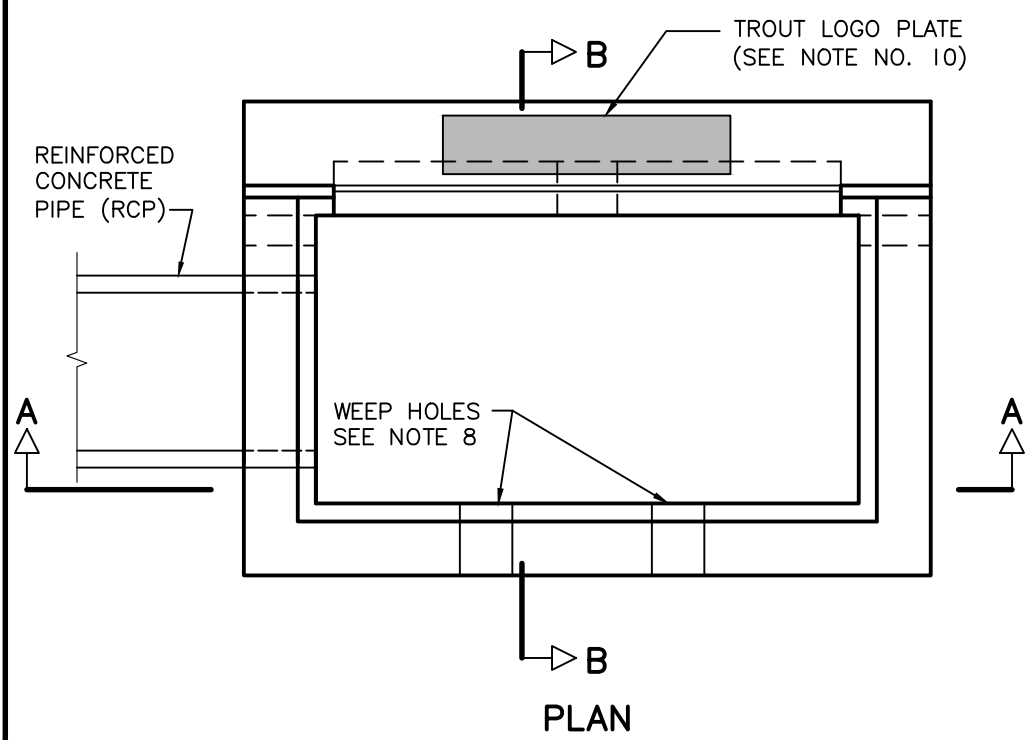

NOTES:

1. CONCRETE INLET AND TOP UNITS SHALL BE AS DETAILED IN PENNDOT STANDARDS FOR ROADWAY CONSTRUCTION, CURRENT EDITION (PDT PUB #72M) RC-45M, "INLETS, CONCRETE TOP UNITS CAST-IN-PLACE AND PRECAST".
2. PROVIDE A MINIMUM OF 4 INCHES AND MAXIMUM OF 8 INCHES VERTICALLY OF PRECAST CONCRETE COLLARS WITH THROUGH-WALL OPENINGS ADJACENT TO SUBGRADE TO SERVE AS WEEP HOLES.
3. ALL EXPOSED EDGES SHALL BE CHAMFERED 1"x1".
4. STEPS SHALL BE PROVIDED WHENEVER STRUCTURE EXCEEDS 4 FEET IN DEPTH.
5. STEP DIMENSIONS AND CONFIGURATION SHALL BE IN ACCORDANCE WITH PENNDOT STANDARDS FOR ROADWAY CONSTRUCTION, CURRENT EDITION (PDT PUB #72M), RC-39M.
6. THE CENTERLINE OF AN INLET SHALL BE NO CLOSER THAN 8 FEET TO THE EDGE OF A DRIVEWAY.
7. PROVIDE STRUCTURAL STEEL GRATE - BICYCLE SAFE, AS DETAILED IN PENNDOT STANDARDS FOR ROADWAY CONSTRUCTION, CURRENT EDITION (PDT PUB #72M), RC-45M, "INLET GRATES".
8. THE BACKFILL AROUND THE WEEPHOLES SHALL NOT CONTAIN SCREENINGS; i.e., PLACE PENNDOT NO. 3 OR LARGER STONES AS REQUIRED BY ENGINEER, WITHOUT SCREENINGS TO ALLOW WATER TO ENTER WEEPHOLES. PLACE GEOTEXTILE FABRIC AROUND BACKFILL TO PREVENT MIGRATION OF SURROUNDING MATERIAL INTO VOIDS OF BACKFILL.
9. THE MANUFACTURER OF THE INLETS SHALL BE INCLUDED ON THE PENNDOT LIST OF APPROVED MANUFACTURERS OF PRECAST CONCRETE PRODUCTS (BULLETIN 15).
10. TOP UNITS MUST CONTAIN THE 24-INCH BY 5-INCH TROUT LOGO PLATE AND TAGS DISPLAYING A DUMPING WARNING AS MANUFACTURED BY EAST JORDAN IRON WORKS INC. (CATALOG NO. 7001PL1) TO BE READ FROM ROADWAY SIDE OF INLET.
11. REFER TO PDT PUB #72M, RC-46M FOR ADDITIONAL REQUIREMENTS.

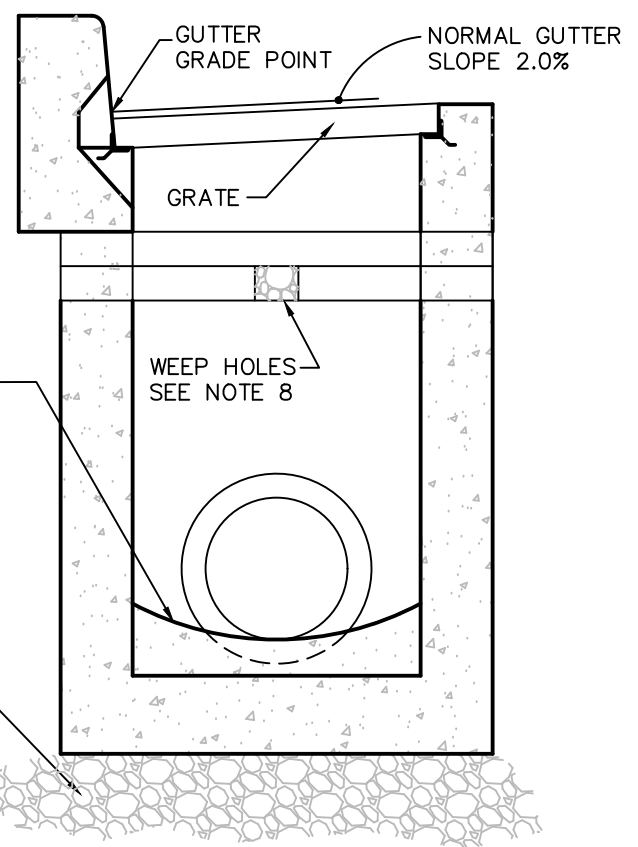
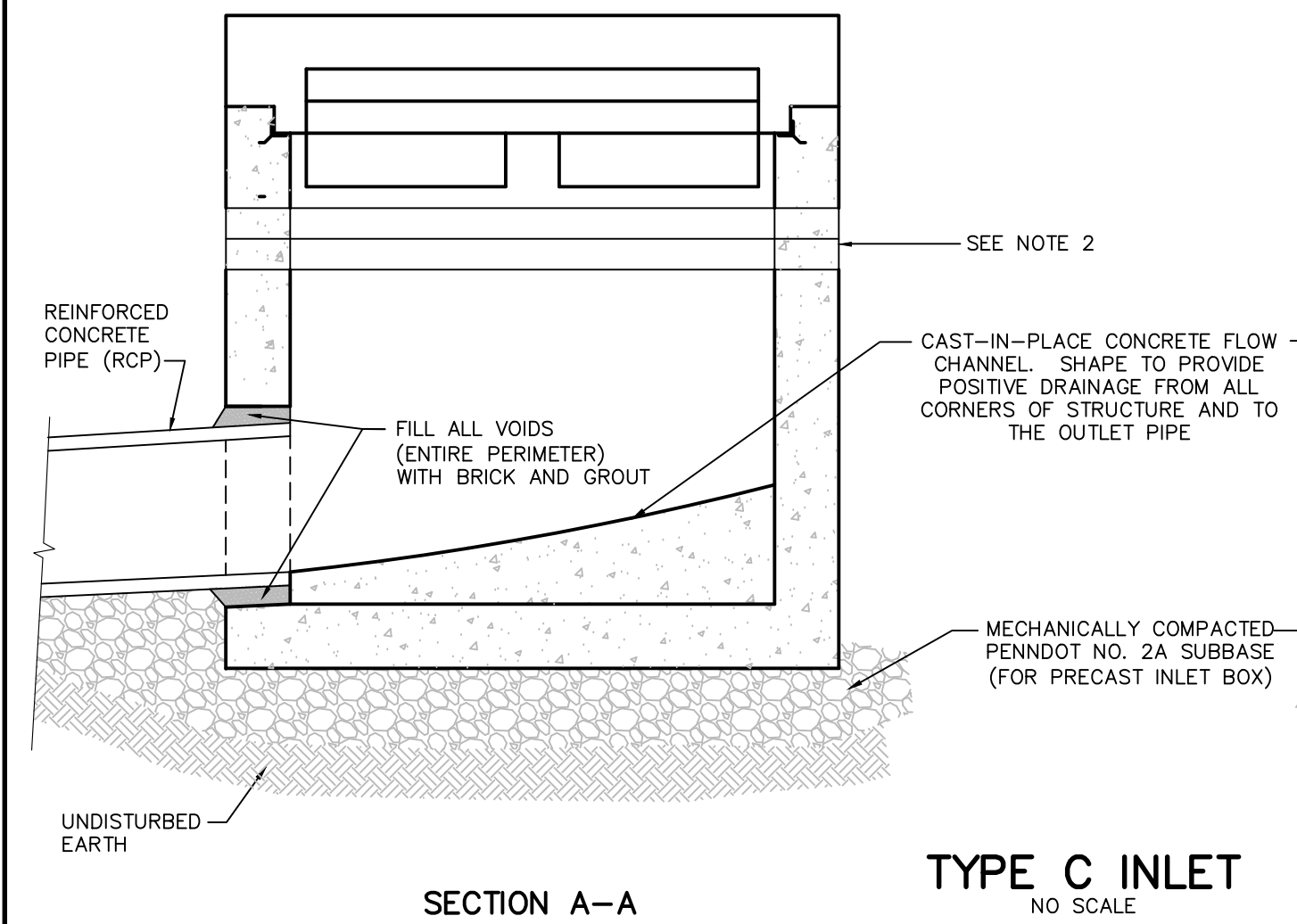

REVISIONS	SOUTH WHITEHALL TOWNSHIP	
	STANDARD CONSTRUCTION DETAILS	
	LEHIGH COUNTY, PENNSYLVANIA	
	STORM DRAINAGE	
PRECAST CONCRETE TYPE C INLET		
THE PIDCOCK COMPANY		DATE: MARCH 2017
CIVIL ENGINEERING AND LAND PLANNING ARCHITECTURE LAND SURVEYING		CHKD BY: RJG
OXFORD DRIVE AT FISH HATCHERY ROAD ALLENTOWN, PENNSYLVANIA		SCALE: NO SCALE
		SWT-D-4

Drawing name: S:\Municipalities\Municipal Standard Construction Documents\South Whitehall Township\WORKING DOCUMENTS\SWT-D-05.dwg Printed: Mar 22, 2017 4:02pm

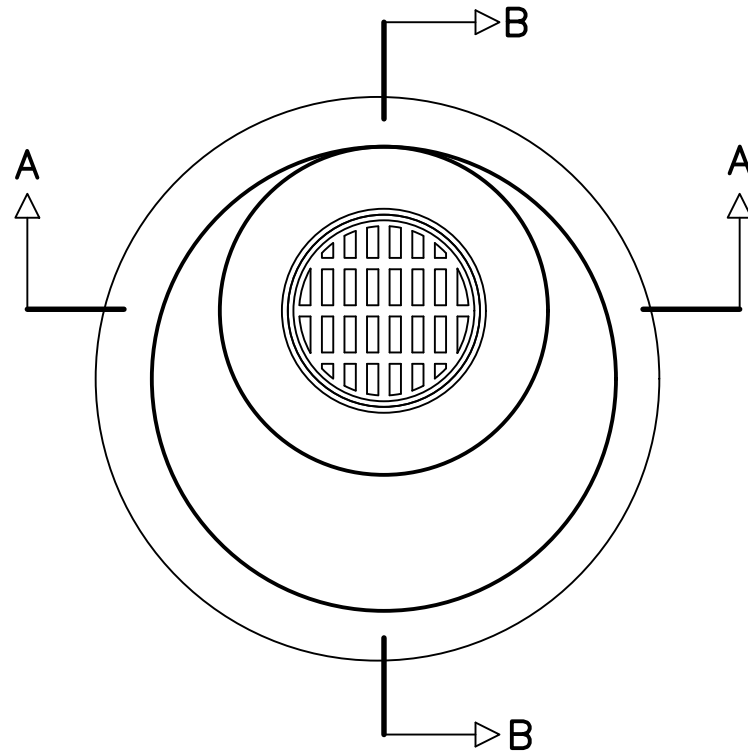

PLAN

NOTE:

1. REFER TO PDT PUB #72M, RC-46M FOR ADDITIONAL REQUIREMENTS.

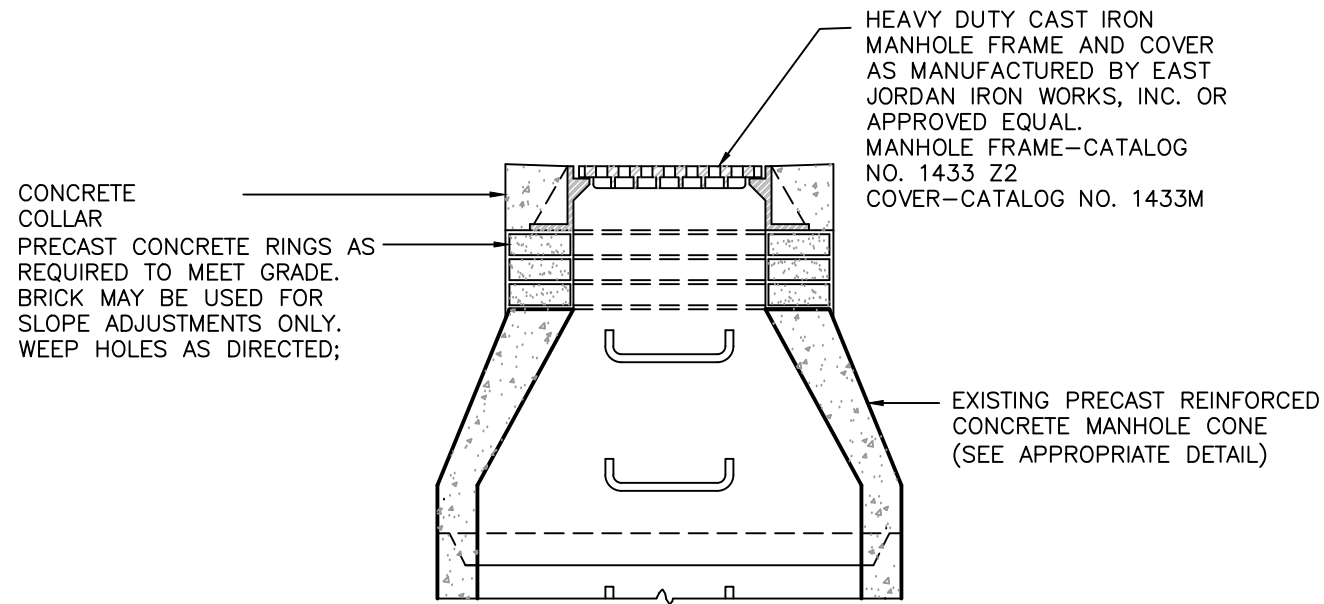

SECTION A-A

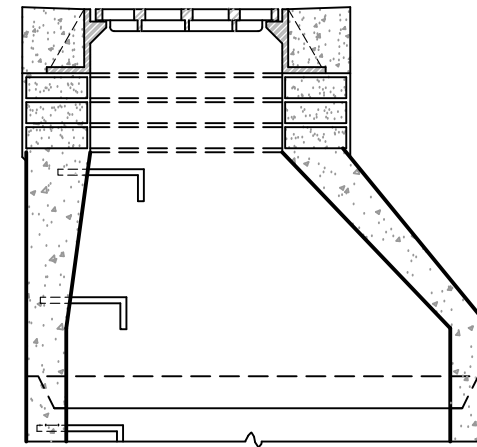

SECTION B-B

MANHOLE TO INLET CONVERSION
NO SCALE

REVISIONS	SOUTH WHITEHALL TOWNSHIP STANDARD CONSTRUCTION DETAILS LEHIGH COUNTY, PENNSYLVANIA	
	STORM DRAINAGE MANHOLE TO INLET CONVERSION	
	THE PIDCOCK COMPANY CIVIL ENGINEERING AND LAND PLANNING ARCHITECTURE LAND SURVEYING OXFORD DRIVE AT FISH HATCHERY ROAD ALLENTOWN, PENNSYLVANIA	
	DATE: MARCH 2017	CHKD BY: RJG
	SCALE: NO SCALE	SCALE: NO SCALE
	SWT-D-5	

Drawing name: S:\Municipalities\Municipal Standard Construction Documents\South Whitehall Township\Working Documents\SWT-D-06.dwg Printed: Mar 22, 2017 - 4:02pm

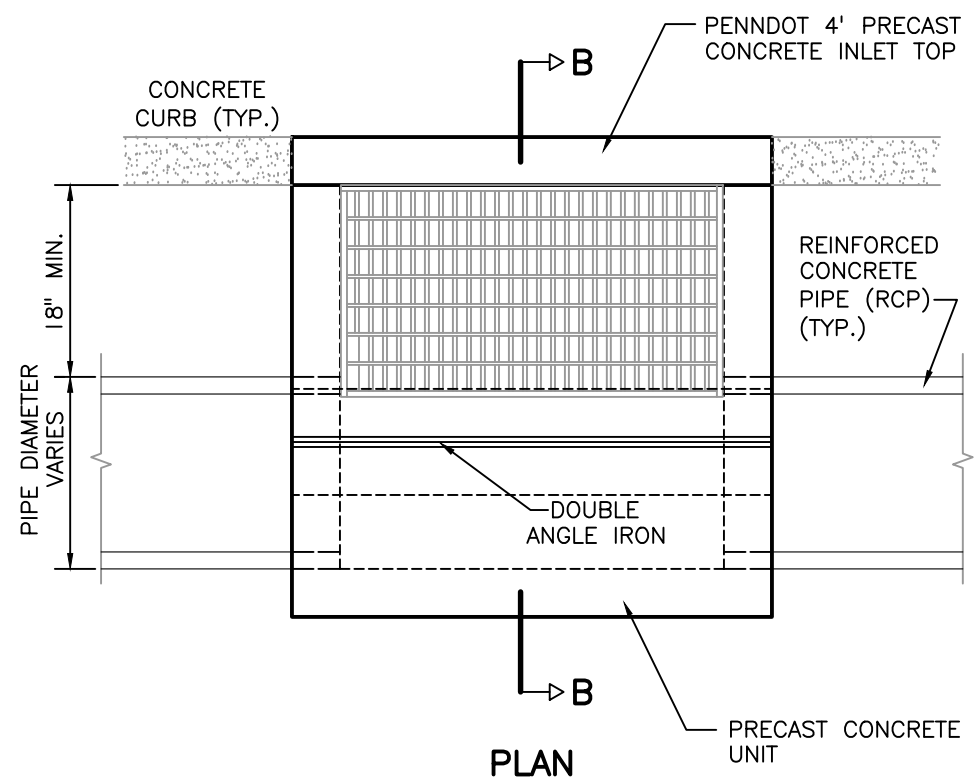
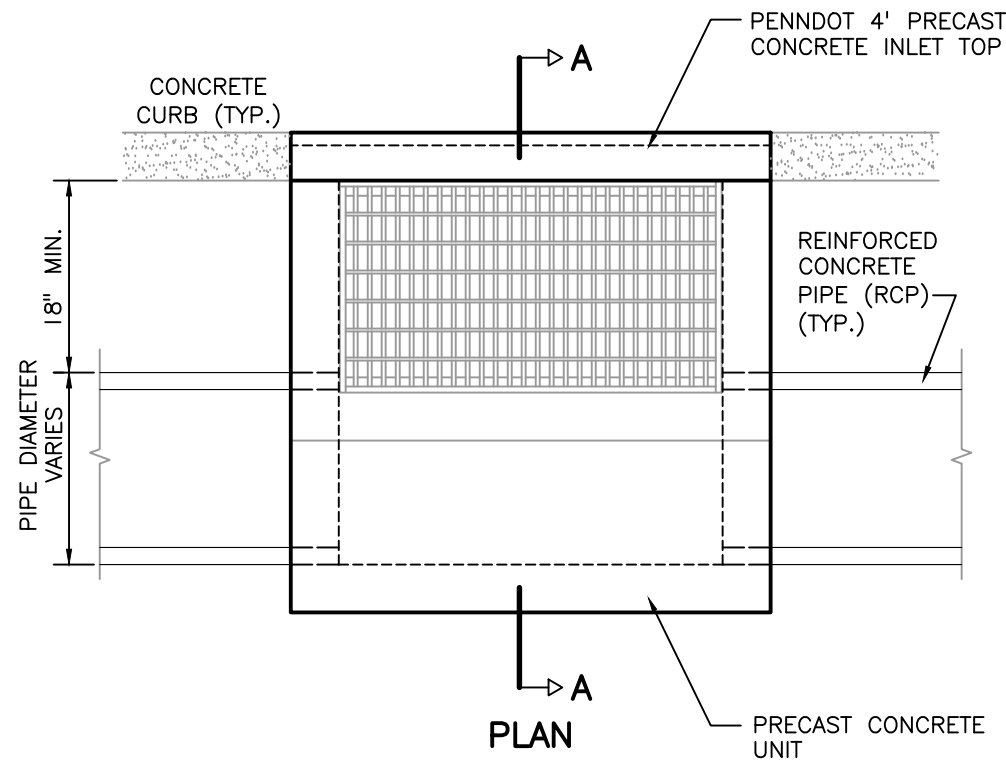

NOTES:

1. TYPE 'C' AND TYPE 'M' TOP UNITS MUST CONTAIN THE TROUT LOGO PLATE AND TAGS DISPLAYING A DUMPING WARNING. SEE DETAILS SWT-D-3 AND SWT-D-4.
2. THE MANUFACTURER OF THE INLETS SHALL BE INCLUDED ON THE PENNDOT LIST OF APPROVED MANUFACTURERS OF PRECAST CONCRETE PRODUCTS (BULLETIN 15).
3. REFER TO PDT PUB #72M, RC-46M FOR ADDITIONAL REQUIREMENTS.
4. SEE DETAILS SWT-D-3 AND SWT-D-4 FOR ADDITIONAL NOTES.

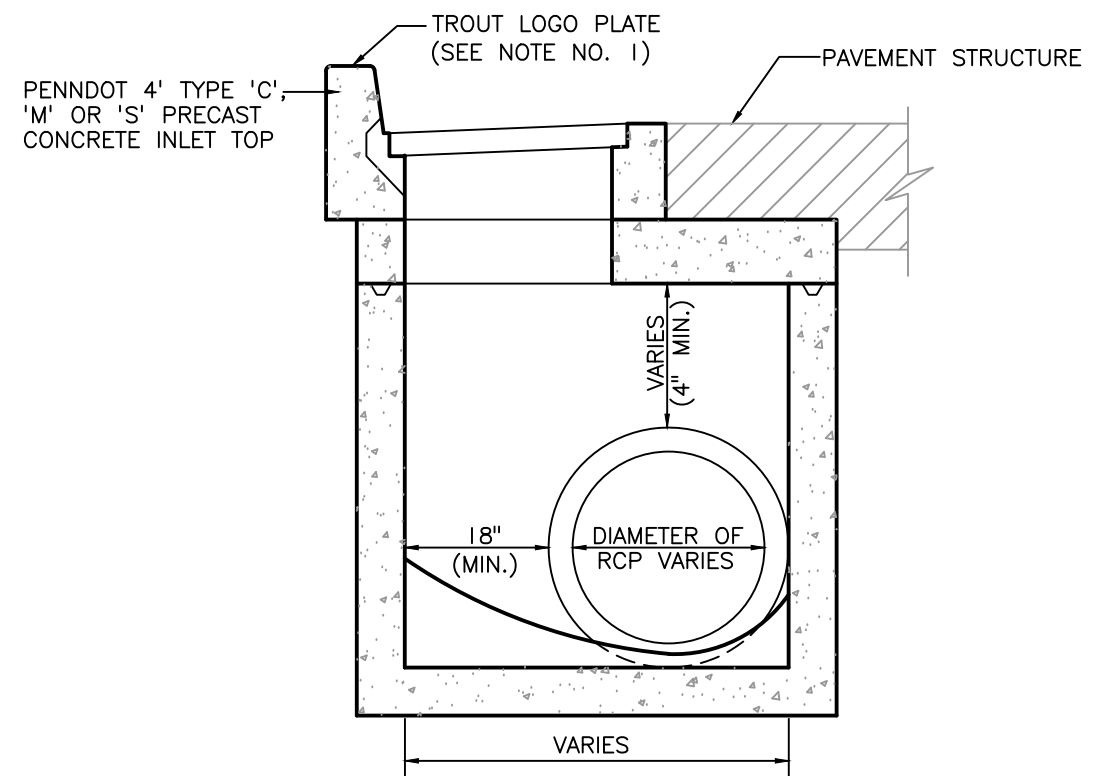

**SECTION A-A
MODIFIED INLET**
NO SCALE

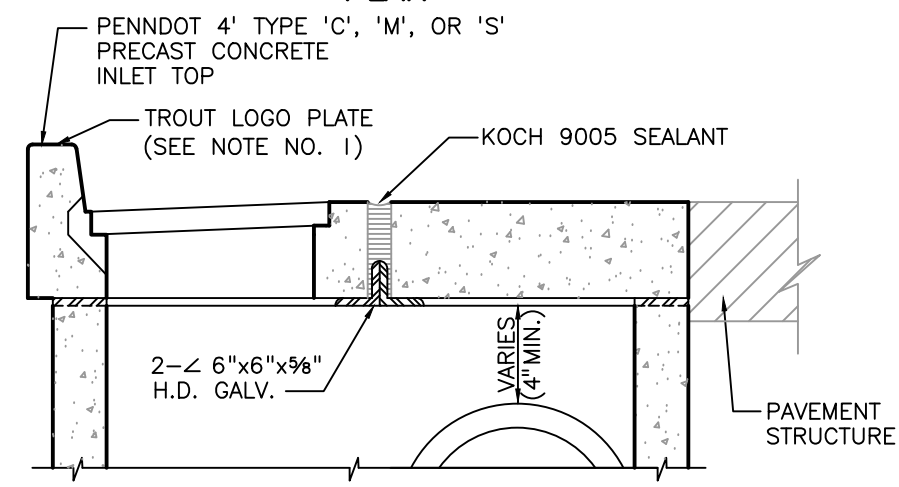

SECTION B-B
**ALTERNATIVE STEEL
SUPPORT TO RECEIVE
PENNDOT TYPE 'C', 'M', OR 'S' INLET**
NO SCALE

REVISIONS	SOUTH WHITEHALL TOWNSHIP STANDARD CONSTRUCTION DETAILS LEHIGH COUNTY, PENNSYLVANIA	
	STORM DRAINAGE MODIFIED INLET	
	THE PIDCOCK COMPANY <small>CIVIL ENGINEERING AND LAND PLANNING ARCHITECTURE LAND SURVEYING</small>	
	<small>DATE: MARCH 2017</small>	<small>CHKD BY: RJK</small>
<small>OXFORD DRIVE AT FISH HATCHERY ROAD ALLENTOWN, PENNSYLVANIA</small>		SWT-D-6

Drawing name: S:\Municipalities\Municipal Standard Construction Documents\South Whitehall Township\SWT-Working Documents\SWT-D-07.dwg Printed: Mar 22, 2017 - 4:02pm

DETAIL DELETED

REVISIONS	SOUTH WHITEHALL TOWNSHIP STANDARD CONSTRUCTION DETAILS LEHIGH COUNTY, PENNSYLVANIA	
	STORM DRAINAGE REINFORCED CONCRETE LOW FLOW CHANNEL	
	THE PIDCOCK COMPANY CIVIL ENGINEERING AND LAND PLANNING ARCHITECTURE LAND SURVEYING OXFORD DRIVE AT FISH HATCHERY ROAD ALLENTOWN, PENNSYLVANIA	
	DATE: MARCH 2017 CHKD BY: RJK SCALE: NO SCALE	SWT-D-7

Drawing name: S:\Municipalities\Municipal Standard Construction Documents\South Whitehall Township\SWT-WORKING DOCUMENTS\SWT-D-08.dwg Printed: Mar 22, 2017 4:02pm

NOTES:

1. THE FENCE FABRIC FOR TANGENT SECTION AND GATES SHALL BE 6-GAUGE THICKNESS (9 GAUGE CORE) PVC COATED WIRE, 2-INCH MESH IN BROWN COLOR AS REVIEWED BY THE TOWNSHIP. ALTERNATE FABRIC SHALL BE 2-INCH MESH, #9 GAUGE WIRE WITH A MINIMUM OF 1.2 OUNCES OF ZINC PER SQUARE FOOT (REQUIRES PRIOR REVIEW AND APPROVAL BY TOWNSHIP).
2. 1 5/8" O.D. MIDDLE RAIL AND 3/8" DIA. TRUSS ROD ADJACENT TO BOTH SIDES OF CORNER AND END POSTS ONLY ON FENCE LINE.
3. TOP AND BOTTOM SELVAGES AT TANGENT SECTION AND GATES SHALL BE KNUCKLED.
4. AT THE TANGENT SECTION, ALTERNATE POST SETTING MAY BE PERMITTED BY THE TOWNSHIP. SEE THE SPECIFICATIONS. ALTERNATE POST SETTING NOT PERMITTED AT GATE POSTS, END POSTS OR CORNER POSTS.
5. PROVIDE A LOCKABLE (PADLOCK THROUGH A LATCH) ASSEMBLY (NO CHAINING) ON ALL GATES. ALL LOCKS TO BE KEYED ALIKE.
6. ALL MATERIALS NOT IDENTIFIED TO BE PVC-COATED SHALL BE HOT DIPPED GALVANIZED.

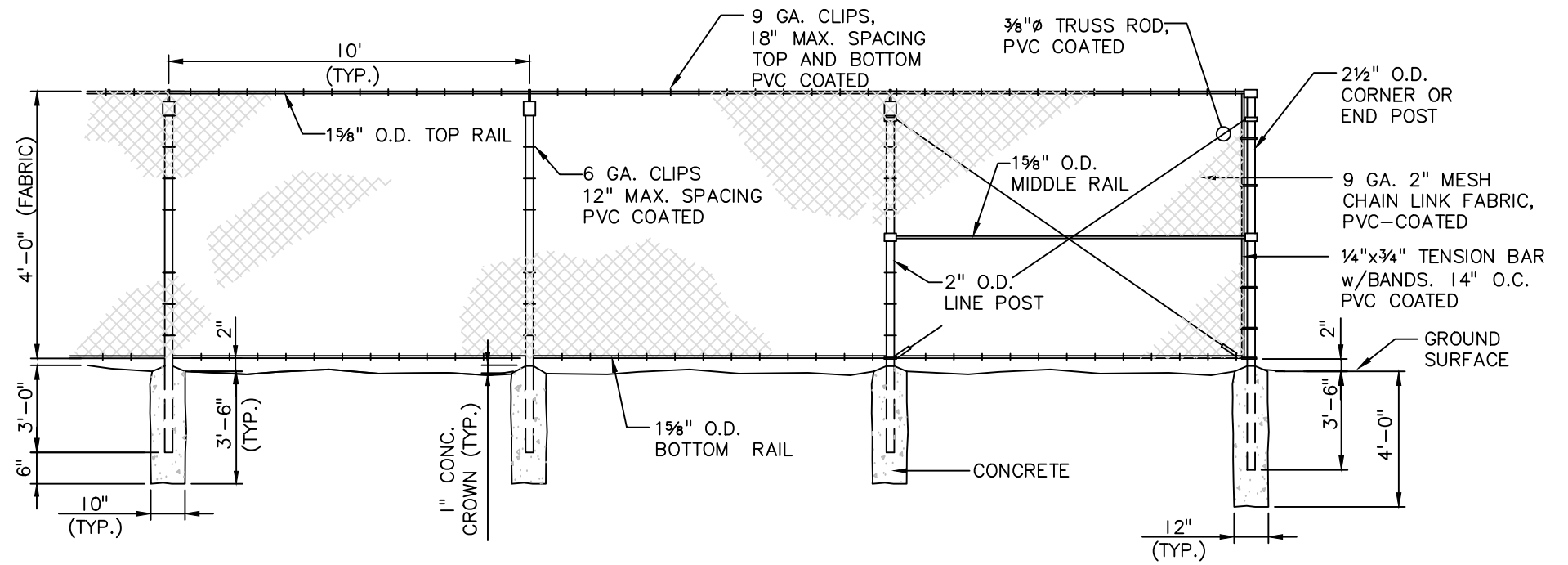

TANGENT SECTION

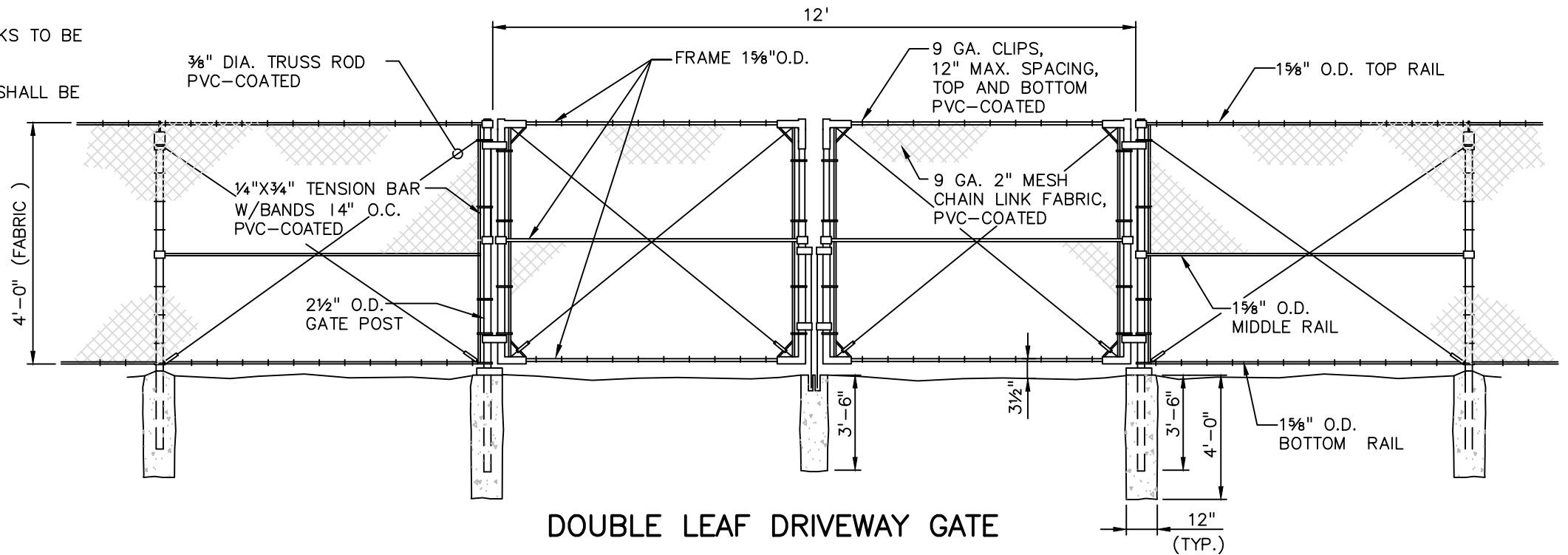

DOUBLE LEAF DRIVEWAY GATE

DETENTION BASIN AND OPEN-SPACE FENCE
NO SCALE

REVISIONS 	SOUTH WHITEHALL TOWNSHIP STANDARD CONSTRUCTION DETAILS LEHIGH COUNTY, PENNSYLVANIA	
	STORM DRAINAGE DETENTION BASIN AND OPEN-SPACE FENCE	
	THE PIDCOCK COMPANY CIVIL ENGINEERING AND LAND PLANNING ARCHITECTURE LAND SURVEYING <small>OXFORD DRIVE AT FISH HATCHERY ROAD ALLENTOWN, PENNSYLVANIA</small>	
	DATE: MARCH 2017 CHKD BY: RJG SCALE: NO SCALE	SWT-D-8

Drawing name: S:\Municipalities\Municipal Standard Construction Documents\South Whitehall Township\WORKING DOCUMENTS\SWT-G-01.dwg Printed: Mar 22, 2017 4:02pm

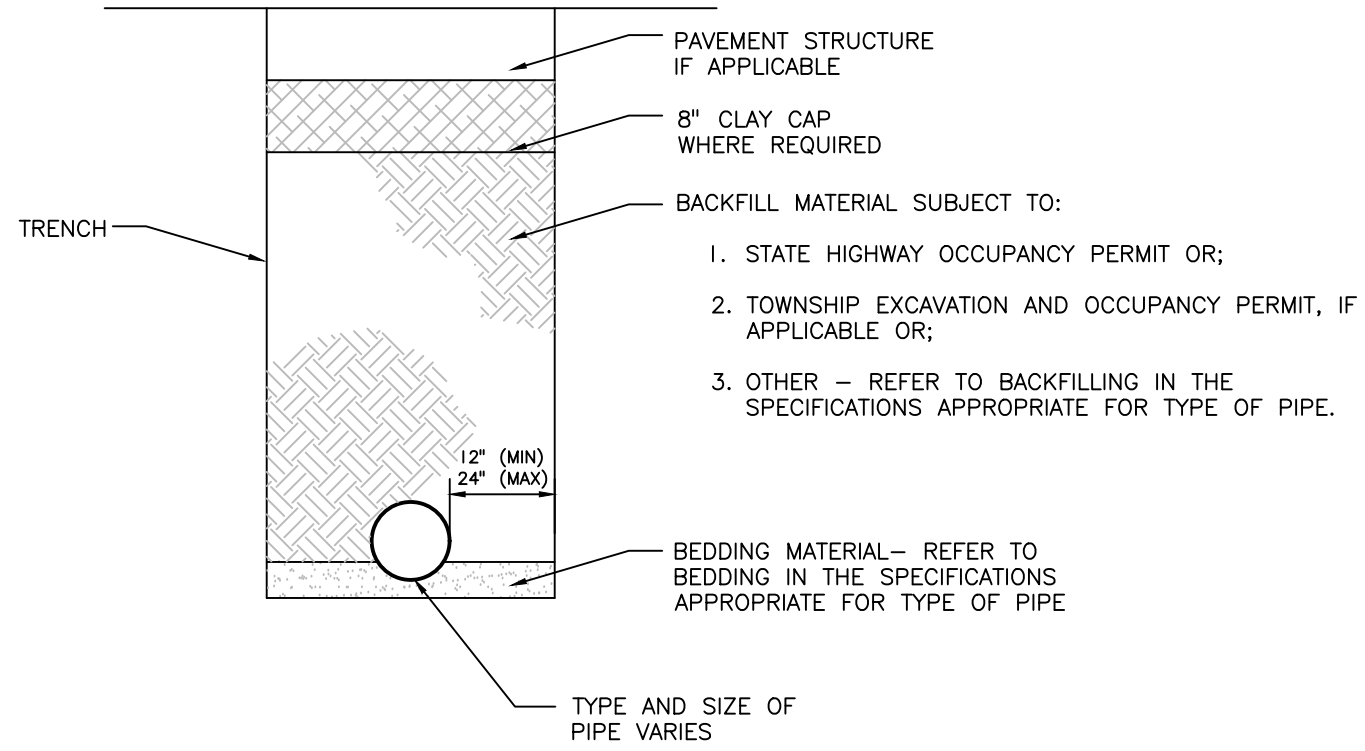

STANDARD TRENCH

NO SCALE

REVISIONS	SOUTH WHITEHALL TOWNSHIP STANDARD CONSTRUCTION DETAILS LEHIGH COUNTY, PENNSYLVANIA	
	GENERAL CONSTRUCTION STANDARD TRENCH	
	THE PIDCOCK COMPANY <small>CIVIL ENGINEERING AND LAND PLANNING ARCHITECTURE LAND SURVEYING</small> <small>OXFORD DRIVE AT FISH HATCHERY ROAD ALLENTOWN, PENNSYLVANIA</small>	
	DATE: MARCH 2017	CHKD BY: RJK
	SCALE: NO SCALE	SCALE: NO SCALE
	SWT-G-1	

Drawing name: S:\Municipalities\Municipal Standard Construction Documents\South Whitehall Township\Working Documents\SWT-R-01.dwg Printed: Mar 22, 2017 4:02pm

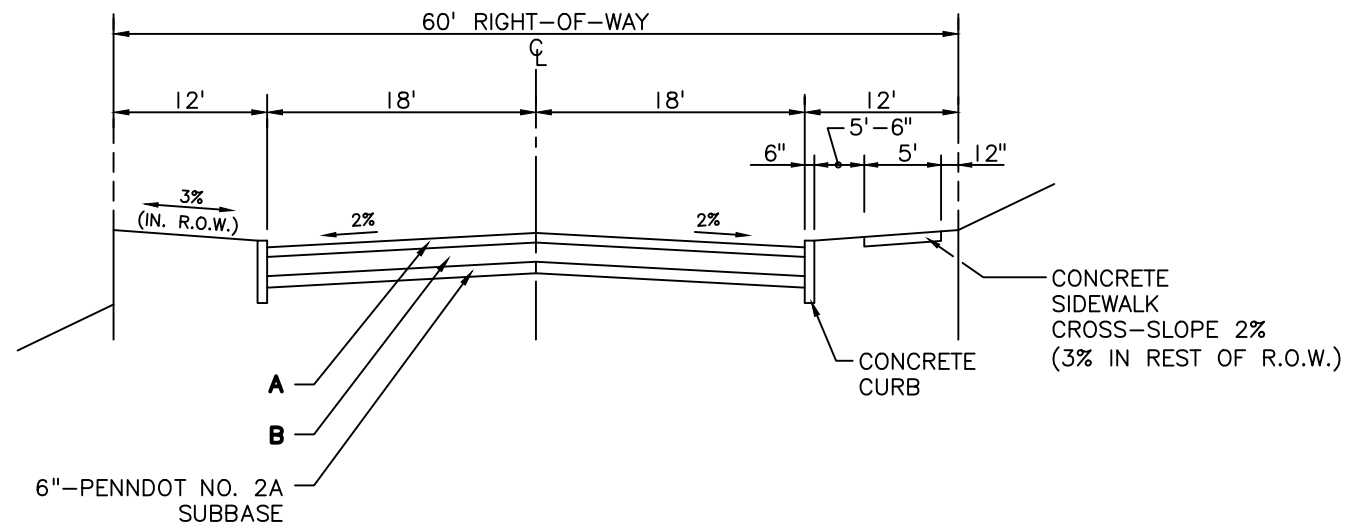

**TYPICAL CROSS SECTION
(LOCAL STREETS)**
NO SCALE

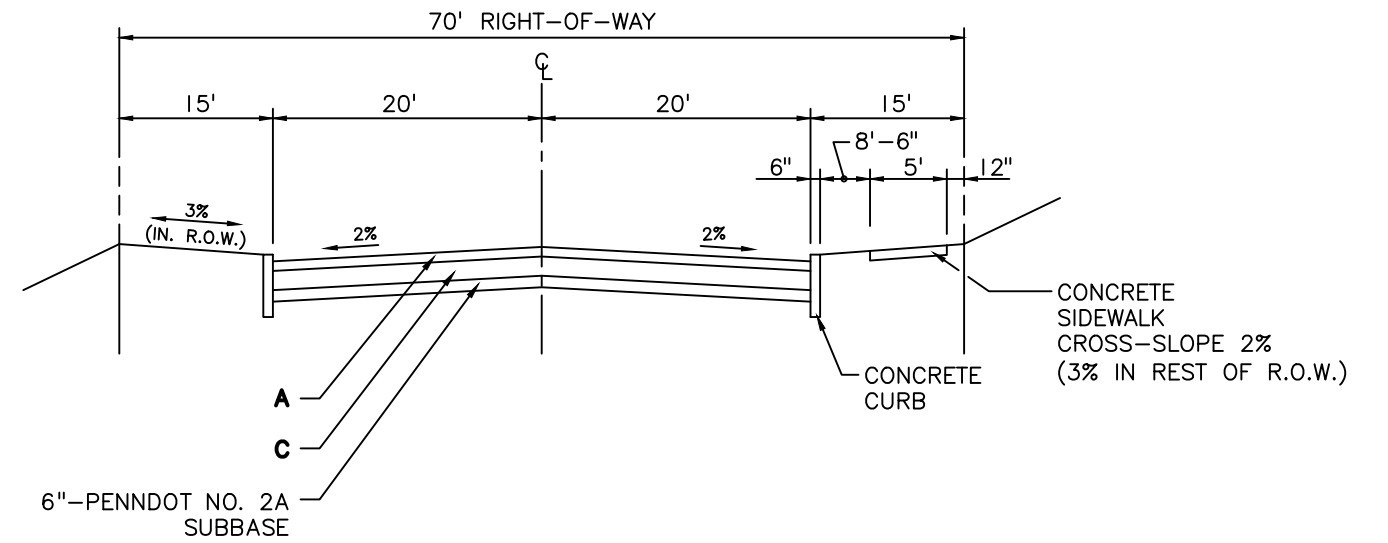

**TYPICAL CROSS SECTION
(COLLECTOR STREETS)**
NO SCALE

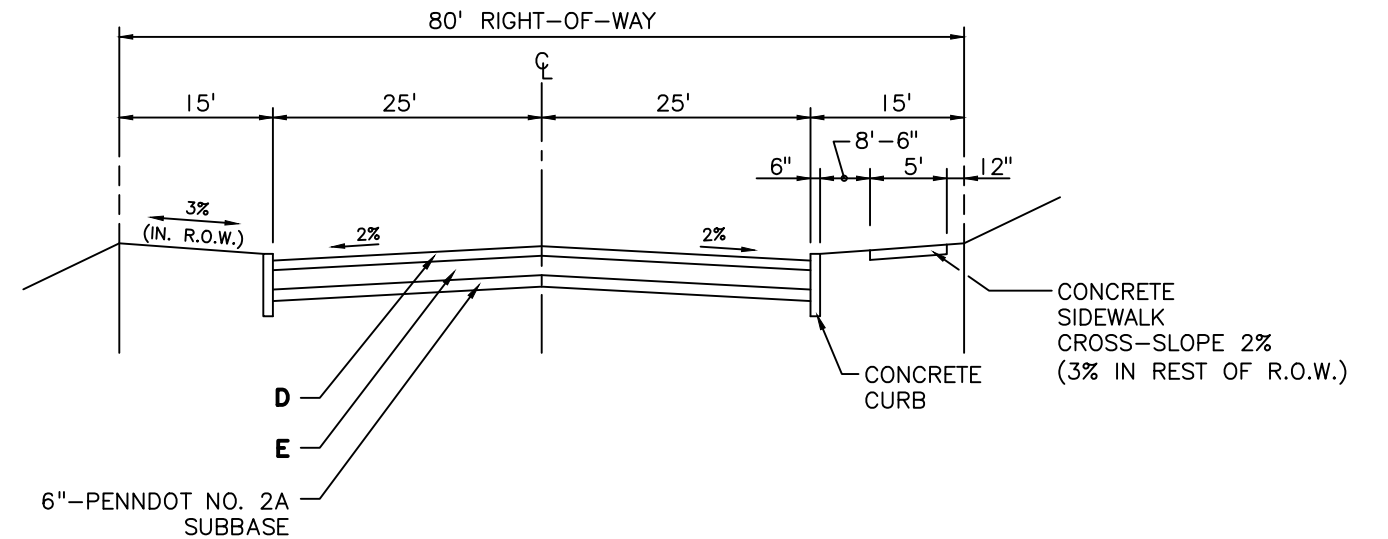

**TYPICAL CROSS SECTION
(ARTERIAL STREETS)**
NO SCALE

PAVEMENT MATERIALS:

- A-** 1½" SUPERPAVE ASPHALT 9.5mm, PG 64-22, 0.0 TO 0.3 MILLION ESAL, SRL-L, HMA WEARING COURSE.
- B-** 4" SUPERPAVE ASPHALT, 25.0mm, PG 64-22, 0.0 TO 0.3 MILLION ESAL, HMA BASE COURSE.
- C-** 4½" SUPERPAVE ASPHALT AS DEFINED IN **B**.
- D-** 1½" SUPERPAVE ASPHALT 9.5mm, PG 64-22, 0.3 TO 3.0 MILLION ESAL, SRL-M, HMA WEARING COURSE
- E-** 5½" SUPERPAVE ASPHALT, 25mm, PG 64-22, 0.3 TO 3.0 MILLION ESAL, HMA BASE COURSE.

NOTES:

1. PROVIDE MATERIALS AND CONSTRUCTION MEETING THE REQUIREMENTS OF PENNDOT SPECIFICATIONS, PUBLICATION 408, CURRENT EDITION, SECTIONS 203, 204, 205, 206, 210, 350, 309, 409, 630 AND 676.
2. SEAL CURB IN ACCORDANCE WITH CONCRETE CURB DETAILS SWT-R-5.
3. THE FOLLOWING ABBREVIATIONS APPEAR ON THIS SHEET:
 - a. ESAL - EQUIVALENT SINGLE AXLE LOAD
 - b. SRL - SKID RESISTANCE LEVEL
 - c. HMA- HOT MIXED ASPHALT
 - d. PG- PERFORMANCE GRADE

REVISIONS	SOUTH WHITEHALL TOWNSHIP	
	STANDARD CONSTRUCTION DETAILS	
	LEHIGH COUNTY, PENNSYLVANIA	
	ROADWAY CONSTRUCTION	
TYPICAL ROADWAY CROSS SECTIONS		
THE PIDCOCK COMPANY		DATE: MARCH 2017
CIVIL ENGINEERING AND LAND PLANNING ARCHITECTURE LAND SURVEYING		CHKD BY: RJG
OXFORD DRIVE AT FISH HATCHERY ROAD ALLENTOWN, PENNSYLVANIA		SCALE: NO SCALE
		SWT-R-1

Drawing name: S:\Municipalities\Municipal Standard Construction Documents\South Whitehall Township\SWT-WORKING DOCUMENTS\SWT-R-02.dwg Printed: Mar 22, 2017 4:02pm

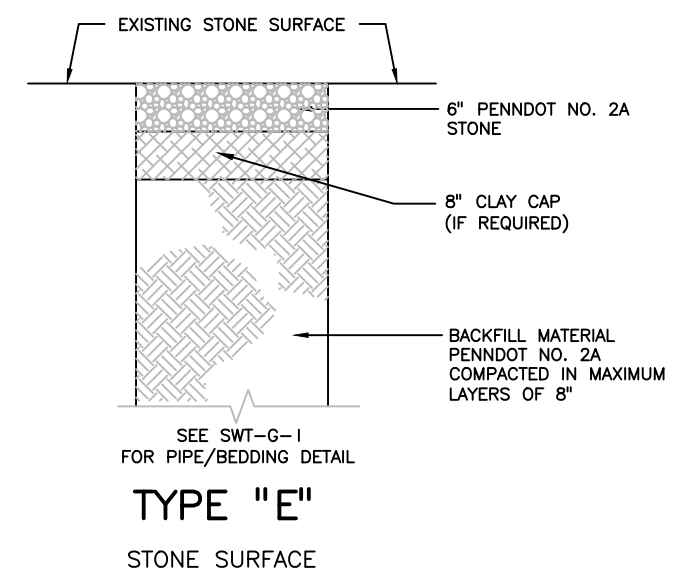
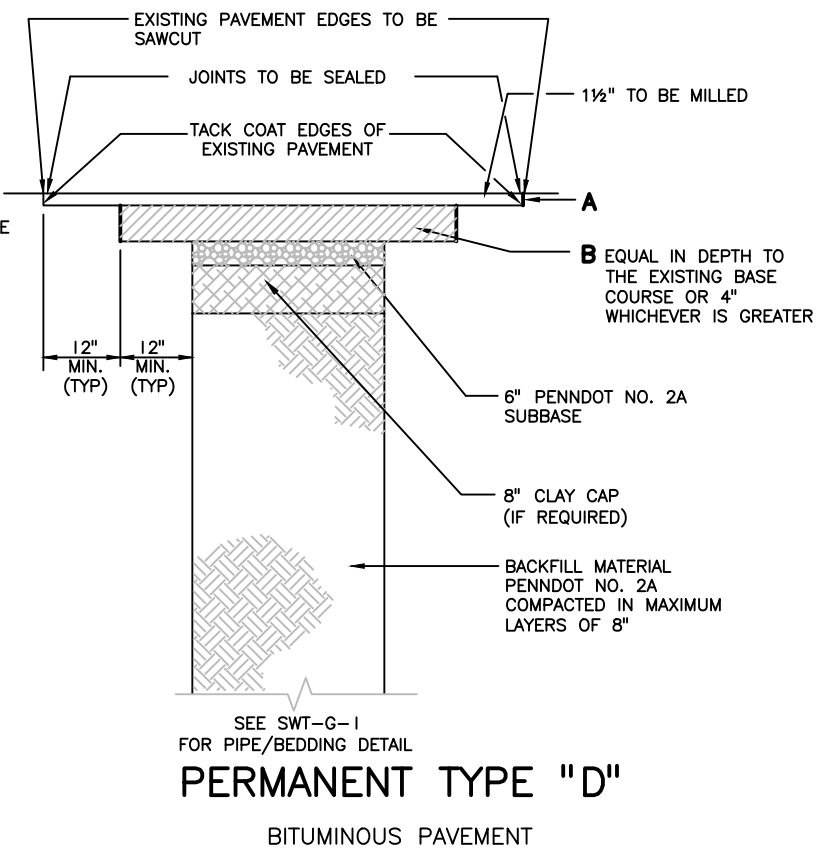
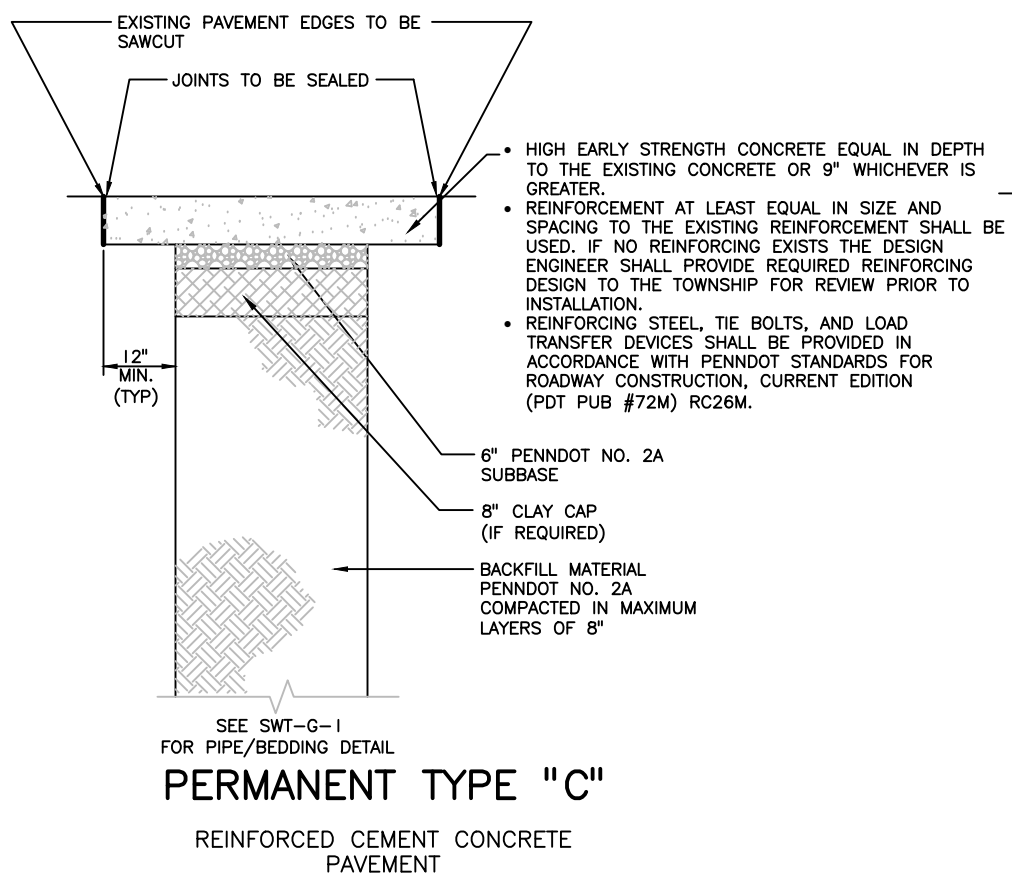

NOTES:

- PROVIDE MATERIALS AND CONSTRUCTION MEETING THE REQUIREMENTS OF PENNDOT SPECIFICATIONS, PUBLICATION 408, CURRENT EDITION, SECTIONS 203, 204, 205, 206, 210, 350, 309 AND 409.
 - PERMANENT BITUMINOUS PAVING TYPE IN TRENCH SHALL MATCH EXISTING TYPE OF PAVING IN THE ROAD.
 - WARNING TAPE SHALL BE PLACED AT A MINIMUM OF 2' ABOVE ANY MAINLINE PIPE OR LATERAL.
- A-** 1 1/2" SUPERPAVE ASPHALT 9.5mm, PG 64-22, 0.0 TO 0.3 MILLION ESAL, SRL-L, HMA WEARING COURSE.
- B-** 4" SUPERPAVE ASPHALT, 25.0mm, PG 64-22, 0.0 TO 0.3 MILLION ESAL, HMA BASE COURSE.
- C-** 5 1/2" SUPERPAVE ASPHALT AS DEFINED IN **B**.

NOTES

- SEAL CURB IN ACCORDANCE WITH CONCRETE CURB DETAILS SWT-R-5
- THE FOLLOWING ABBREVIATIONS APPEAR ON THIS SHEET:
 - a. ESAL - EQUIVALENT SINGLE AXLE LOAD
 - b. SRL - SKID RESISTANCE LEVEL
 - c. HMA - HOT MIXED ASPHALT
 - d. PG - PERFORMANCE GRADE

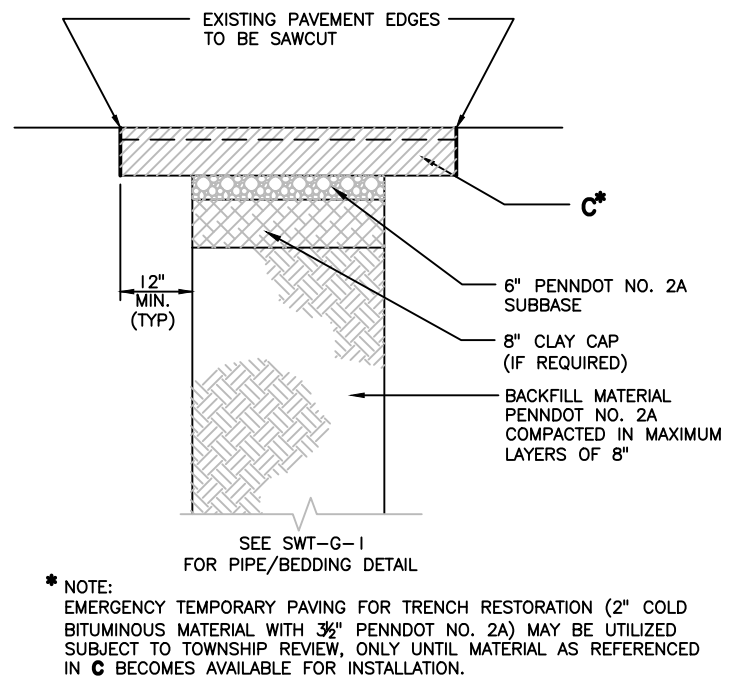
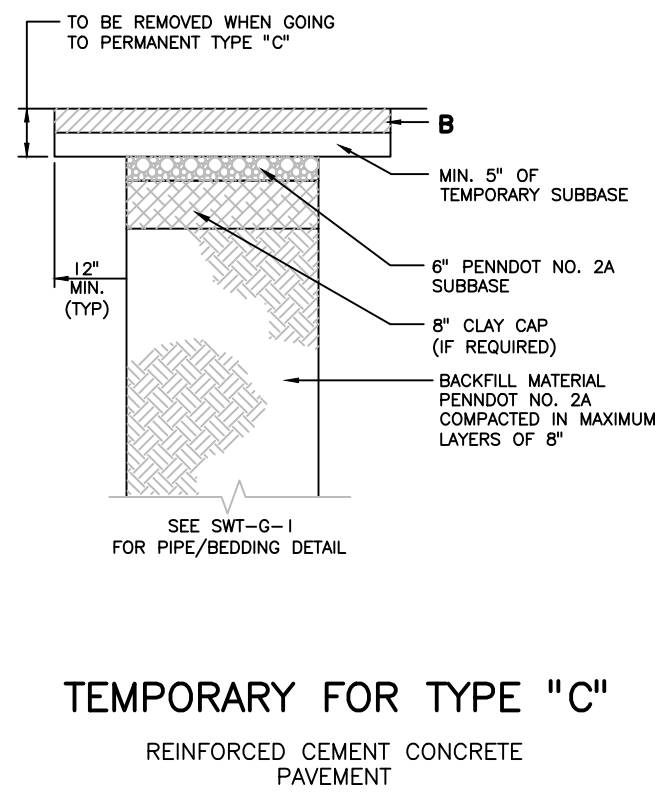

* NOTE:
EMERGENCY TEMPORARY PAVING FOR TRENCH RESTORATION (2" COLD BITUMINOUS MATERIAL WITH 3/2" PENNDOT NO. 2A) MAY BE UTILIZED SUBJECT TO TOWNSHIP REVIEW, ONLY UNTIL MATERIAL AS REFERENCED IN **C** BECOMES AVAILABLE FOR INSTALLATION.

NON-STATE HIGHWAY PAVEMENT RESTORATION

NO SCALE

REVISIONS	SOUTH WHITEHALL TOWNSHIP STANDARD CONSTRUCTION DETAILS LEHIGH COUNTY, PENNSYLVANIA
	ROADWAY CONSTRUCTION NON-STATE HIGHWAY PAVEMENT RESTORATION
	THE PIDCOCK COMPANY CIVIL ENGINEERING AND LAND PLANNING ARCHITECTURE LAND SURVEYING
	DATE: MARCH 2017 CHKD BY: RJG SCALE: NO SCALE
	SWT-R-2

Drawing name: S:\Municipalities\Municipal Standard Construction Documents\South Whitehall Township\Working Documents\SWT-R-03.dwg Printed: Mar 22, 2017 4:02pm

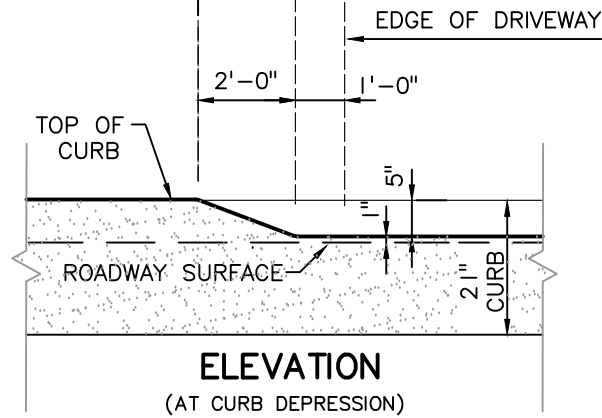
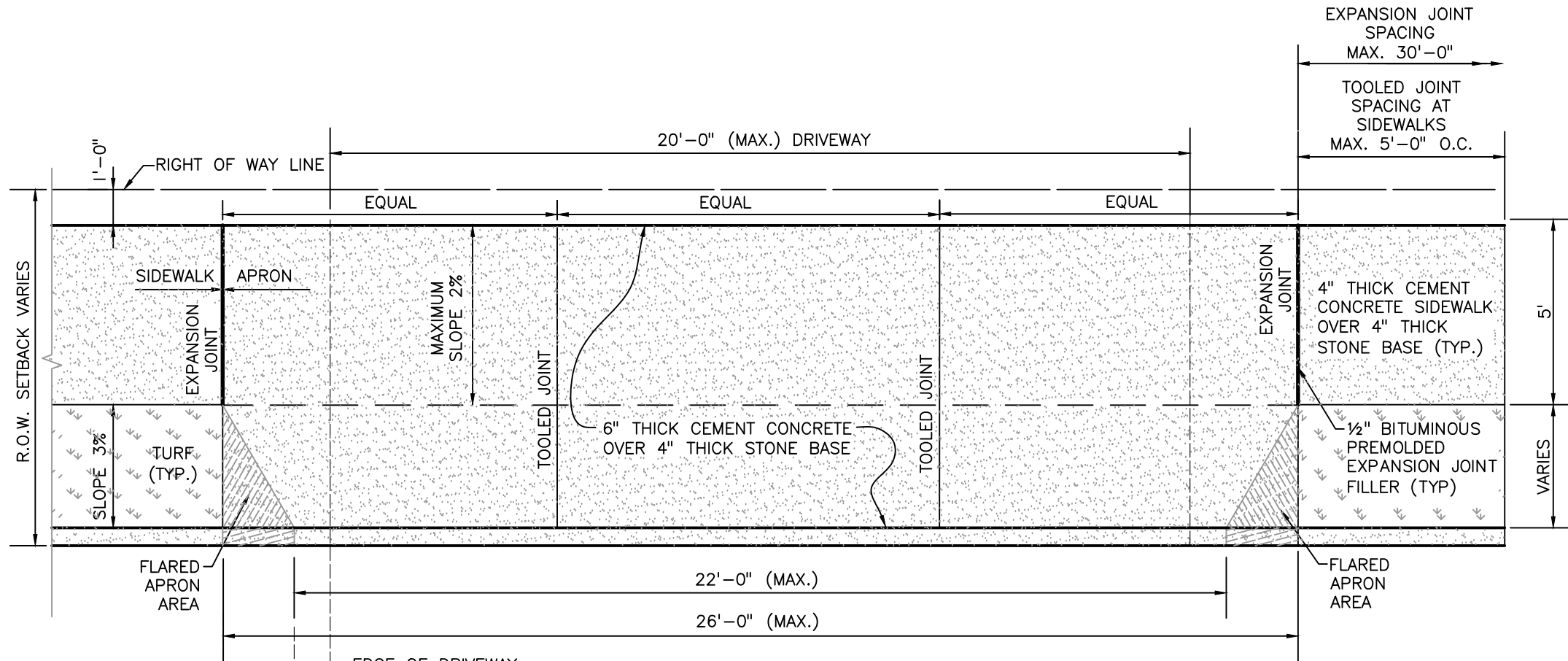

**RESIDENTIAL
SIDEWALK AND DRIVEWAY APRON PLAN**
NO SCALE

NOTES:

1. BASE SHALL BE PENNDOT NO. 2A MECHANICALLY COMPACTED ON A PREPARED SUBGRADE.
2. CONCRETE DRIVEWAY APRONS SHALL BE INSTALLED WHERE CONCRETE CURB DEPRESSIONS HAVE BEEN INSTALLED.
3. THE EDGE OF A DRIVEWAY SHALL BE NO CLOSER THAN 8 FEET FROM THE CENTERLINE OF AN INLET.

REVISIONS	SOUTH WHITEHALL TOWNSHIP STANDARD CONSTRUCTION DETAILS LEHIGH COUNTY, PENNSYLVANIA	
	ROADWAY CONSTRUCTION RESIDENTIAL SIDEWALK AND DRIVEWAY APRON	
	THE PIDCOCK COMPANY CIVIL ENGINEERING AND LAND PLANNING ARCHITECTURE LAND SURVEYING OXFORD DRIVE AT FISH HATCHERY ROAD ALLENTOWN, PENNSYLVANIA	
	DATE: MARCH 2017	CHKD BY: RJG
	SCALE: NO SCALE	SCALE: NO SCALE
	SWT-R-3	

Drawing name: S:\Municipalities\Municipal Standard Construction Documents\South Whitehall Township\Working Documents\SWT-R-04.dwg Printed: Mar 22, 2017 4:02pm

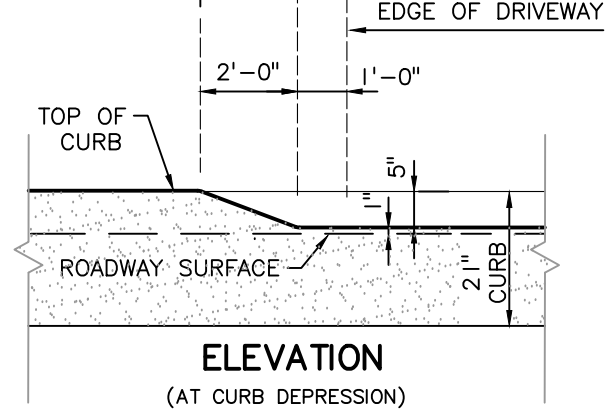
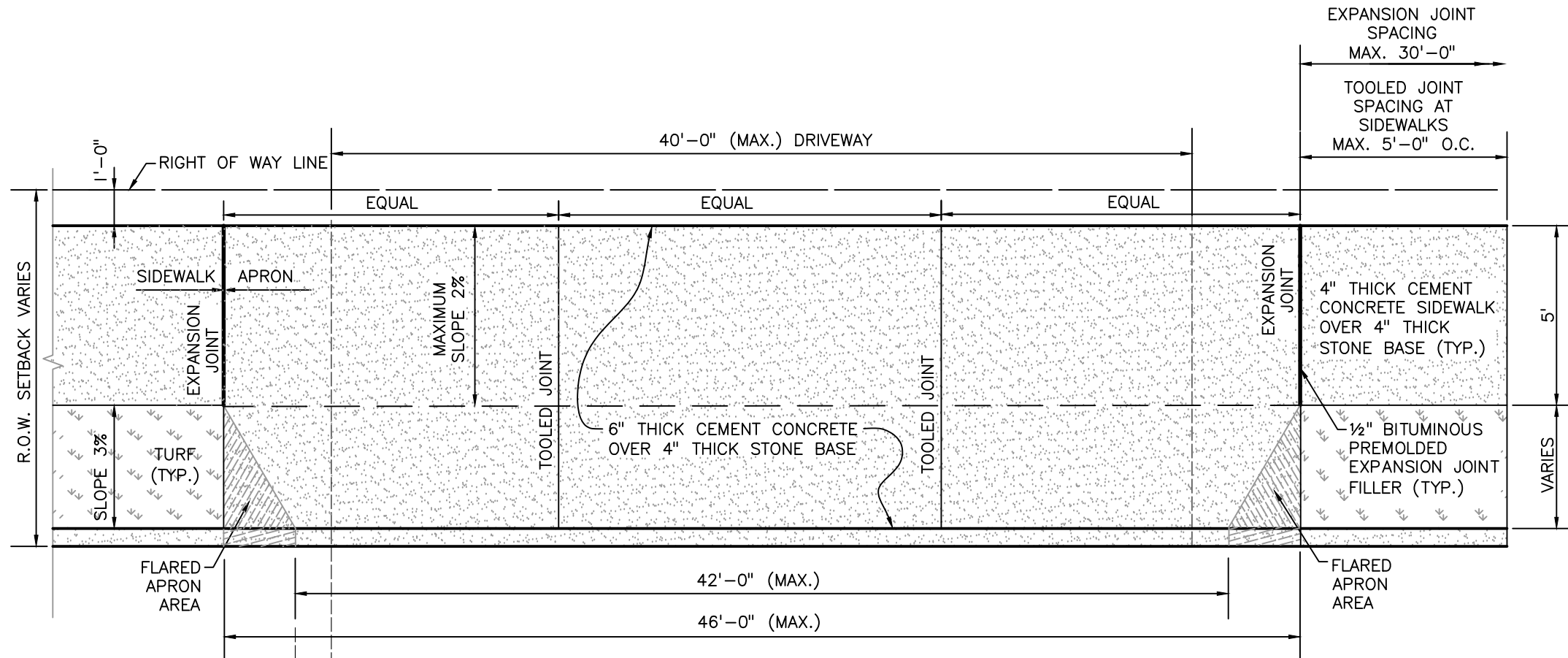

**NON-RESIDENTIAL
SIDEWALK AND DRIVEWAY APRON PLAN**
NO SCALE

NOTES:

1. BASE SHALL BE PENNDOT NO. 2A MECHANICALLY COMPACTED ON A PREPARED SUBGRADE.
2. CONCRETE DRIVEWAY APRONS SHALL BE INSTALLED WHERE CONCRETE CURB DEPRESSIONS HAVE BEEN INSTALLED.
3. NON-RESIDENTIAL DRIVEWAY APRON SHALL BE REINFORCED WITH A MINIMUM 6x6-W2.9xW2.9 WELDED WIRE FABRIC. TERMINATE REINFORCING AT EXPANSION JOINTS. REINFORCING SHALL BE AS SPECIFIED BY DESIGN ENGINEER BASED ON SPECIFIC USE/LOADING REQUIREMENTS.
4. PROVIDE DRIVEWAY APRONS AT ACCESS POINTS TO UTILITY EASEMENTS AT LOCATIONS AS DIRECTED BY SOUTH WHITEHALL TOWNSHIP.
5. THE EDGE OF A DRIVEWAY SHALL BE NO CLOSER THAN 8 FEET FROM THE CENTERLINE OF AN INLET.

REVISIONS	SOUTH WHITEHALL TOWNSHIP STANDARD CONSTRUCTION DETAILS LEHIGH COUNTY, PENNSYLVANIA	
	ROADWAY CONSTRUCTION NON-RESIDENTIAL SIDEWALK AND DRIVEWAY APRON	
	THE PIDCOCK COMPANY <small>CIVIL ENGINEERING AND LAND PLANNING ARCHITECTURE LAND SURVEYING</small>	
	<small>DATE: MARCH 2017</small>	<small>CHKD BY: RJG</small>
	<small>SCALE: NO SCALE</small>	SWT-R-4

Drawing name: S:\Municipalities\Municipal Standard Construction Documents\South Whitehall Township\Working Documents\SWT-R-05.dwg Printed: Mar 22, 2017 4:03pm

SEAL CURB IN A NEAT AND UNIFORM MANNER WITH KOCH 9005 RUBBERIZED BITUMINOUS SEALER

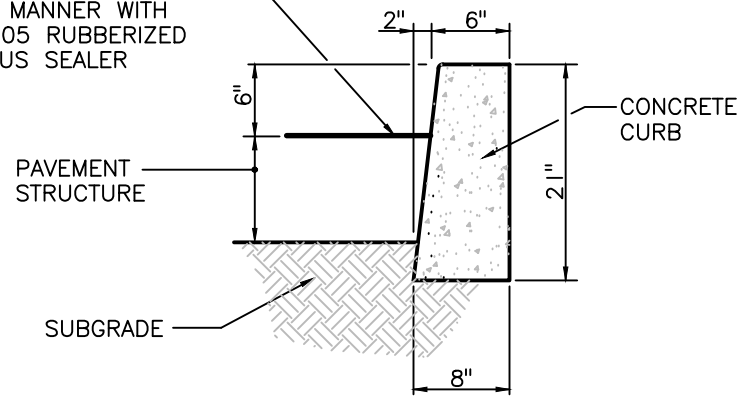

TYPICAL CURB
NO SCALE

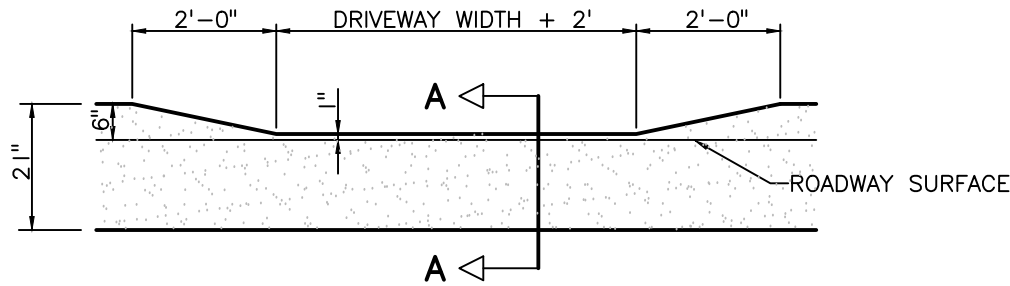

SECTION A-A
DEPRESSED CURB
NO SCALE

CONCRETE CURB
NO SCALE

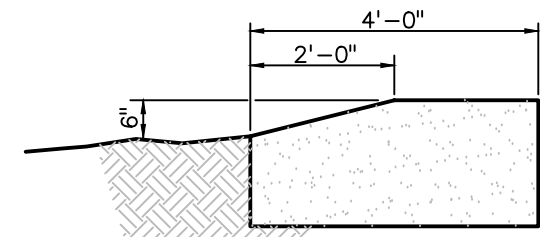

TAPERED END
NO SCALE

NOTES:

1. EXISTING CURB REMOVAL SHALL BE IN COMPLETE SECTIONS (JOINT TO JOINT), NOT PARTIAL SECTIONS.
2. PROVIDE MATERIALS AND CONSTRUCTION MEETING THE REQUIREMENTS OF PENNDOT SPECIFICATIONS, PUBLICATION 408, CURRENT EDITION, SECTION 630.
3. SPACE CONTRACTION JOINTS IN UNIFORM LENGTHS OR SECTIONS, 10'-0" MAX. TO 4'-0" MIN.
4. PLACE 1/2 INCH BITUMINOUS PREMOLDED EXPANSION JOINT FILLER MATERIAL AT STRUCTURES AND AT THE END OF THE WORK DAY. CUT MATERIAL TO CONFORM TO AREA ADJACENT TO CURB OR TO CONFORM TO CROSS SECTIONAL AREA OF CURB.
5. EXPANSION JOINTS SHALL BE SPACED AS REQUIRED BY THE TOWNSHIP - TYPICALLY 30' O. C.

REVISIONS	SOUTH WHITEHALL TOWNSHIP STANDARD CONSTRUCTION DETAILS LEHIGH COUNTY, PENNSYLVANIA	
	ROADWAY CONSTRUCTION CONCRETE CURB	
	THE PIDCOCK COMPANY <small>CIVIL ENGINEERING AND LAND PLANNING ARCHITECTURE LAND SURVEYING</small>	
	<small>DATE: MARCH 2017</small>	<small>CHKD BY: RJG</small>
<small>OXFORD DRIVE AT FISH HATCHERY ROAD ALLENTOWN, PENNSYLVANIA</small>		SWT-R-5

Drawing name: S:\Municipalities\Municipal Standard Construction Documents\South Whitehall Township\SWT-Working Documents\SWT-R-06.dwg Printed: Mar 22, 2017 - 4:03pm

DETAIL DELETED

REVISIONS	SOUTH WHITEHALL TOWNSHIP STANDARD CONSTRUCTION DETAILS LEHIGH COUNTY, PENNSYLVANIA	
	ROADWAY CONSTRUCTION SIDEWALK AND CURB RAMP	
	THE PIDCOCK COMPANY CIVIL ENGINEERING AND LAND PLANNING ARCHITECTURE LAND SURVEYING OXFORD DRIVE AT FISH HATCHERY ROAD ALLENTOWN, PENNSYLVANIA	
	DATE: MARCH 2017 CHKD BY: RJG SCALE: NO SCALE	SWT-R-6

Drawing name: S:\Municipalities\Municipal Standard Construction Documents\South Whitehall Township\Working Documents\SWT-R-07.dwg Printed: Mar 22, 2017 4:03pm

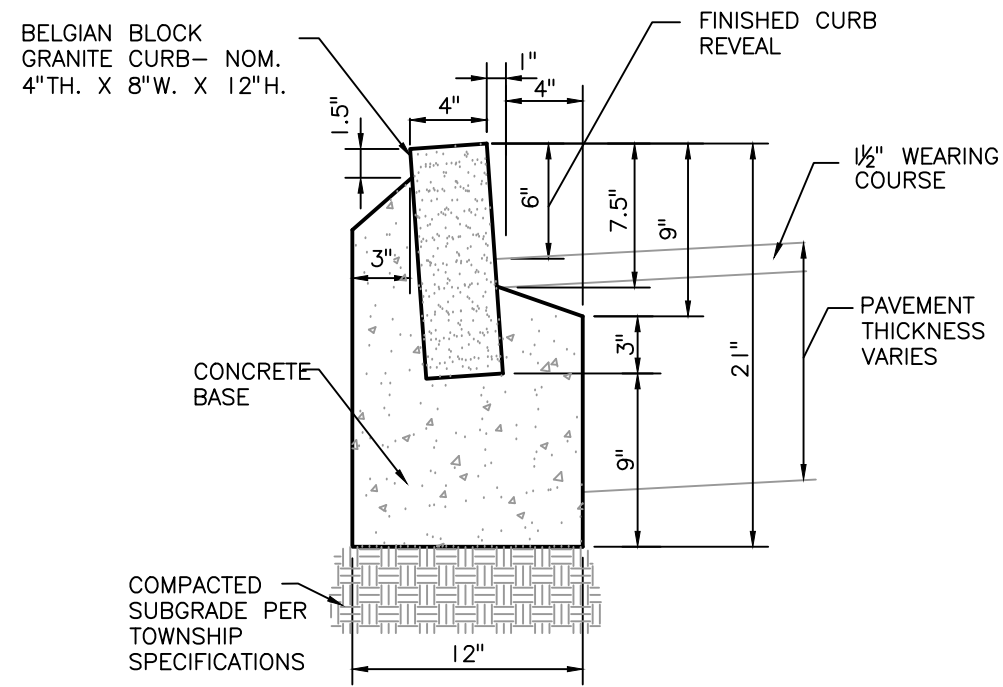

**TYPICAL
BELGIAN BLOCK
GRANITE CURB**

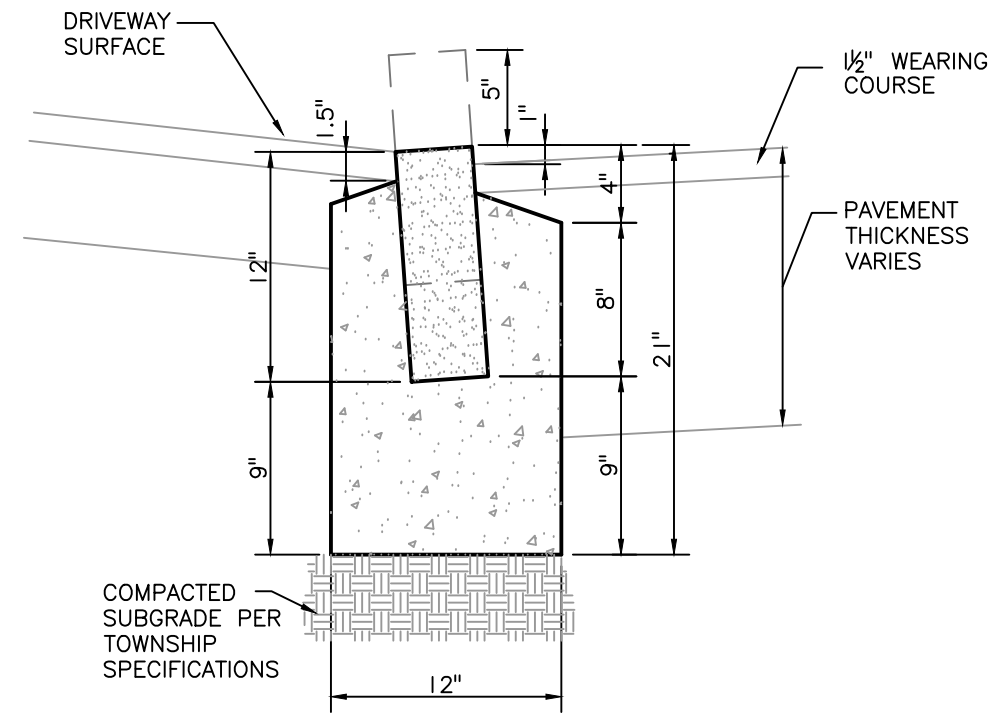

**TYPICAL
BELGIAN BLOCK
GRANITE CURB AT
DRIVEWAY APRON**

NOTES:

1. 1:1 CEMENT-SAND MORTAR JOINTS SHALL NOT BE MORE THAN 3/8" WIDE.
2. TRANSVERSE JOINTS 1/2" WIDE SHALL BE INSTALLED IN THE CURB A MAXIMUM OF 60' APART, AND ON BOTH SIDES AT ALL INLETS, AND SHALL BE FILLED WITH PREFORMED BITUMINOUS-IMPREGNATED FIBER JOINT FILLER RECESSED 1/4" IN FROM FRONT FACE AND TOP OF CURB.

BELGIAN BLOCK GRANITE CURB

NO SCALE

REVISIONS	SOUTH WHITEHALL TOWNSHIP STANDARD CONSTRUCTION DETAILS LEHIGH COUNTY, PENNSYLVANIA	
	ROADWAY CONSTRUCTION BELGIAN BLOCK GRANITE CURB	
	THE PIDCOCK COMPANY CIVIL ENGINEERING AND LAND PLANNING ARCHITECTURE LAND SURVEYING OXFORD DRIVE AT FISH HATCHERY ROAD ALLENTOWN, PENNSYLVANIA	
	DATE: MARCH 2017	CHKD BY: RJG SCALE: NO SCALE
		SWT-R-7

Drawing name: S:\Municipalities\Municipal Construction Documents\South Whitehall Township\Working Documents\SWT-R-08.dwg Printed: Mar 22, 2017 4:03pm

NOTES:

1. LOCATION. PERMANENT REFERENCE MONUMENTS SHALL BE LOCATED AT EACH STREET INTERSECTION, AT THE BEGINNING AND ENDING OF ALL STREET CURVES, AND AT EXTERIOR CORNERS OF THE SUBDIVISION DESIGNATED BY THE TOWNSHIP ENGINEER.
2. THE DEVELOPER MAY INSTALL MONUMENTS ON ONLY ONE SIDE OF THE STREET PROVIDED THAT ENOUGH MONUMENTS ARE SET TO PERMIT A SURVEYOR TO STAKE OUT ACCURATELY ANY BUILDING LOT ON THE FINAL PLAN.
3. TYPE. REFERENCE MONUMENTS SHALL BE CONSTRUCTED OF STEEL REINFORCED PORTLAND CEMENT TO THE DIMENSIONS SHOWN ON THIS DRAWING, OR AS REVIEWED IN ADVANCE IN WRITING BY THE TOWNSHIP ENGINEER.
4. PLACEMENT. REFERENCED MONUMENTS SHALL BE PLACED SO THAT THE TOP OF THE MONUMENT IS FLUSH WITH FINISH GRADE.

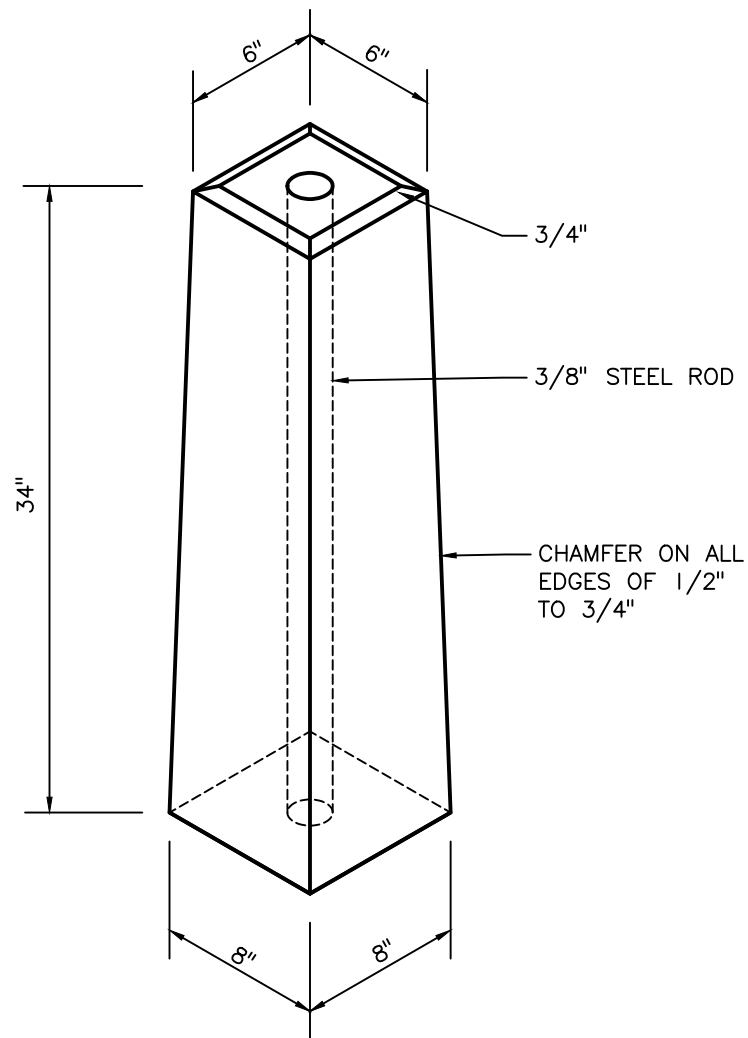

STANDARD CONCRETE MONUMENT
NO SCALE

REVISIONS	SOUTH WHITEHALL TOWNSHIP STANDARD CONSTRUCTION DETAILS LEHIGH COUNTY, PENNSYLVANIA	
	ROADWAY CONSTRUCTION STANDARD CONCRETE MONUMENT	
	THE PIDCOCK COMPANY <small>CIVIL ENGINEERING AND LAND PLANNING ARCHITECTURE LAND SURVEYING</small> <small>OXFORD DRIVE AT FISH HATCHERY ROAD ALLENTOWN, PENNSYLVANIA</small>	
	DATE: MARCH 2017 CHKD BY: RJK SCALE: NO SCALE	SWT-R-8

Drawing name: S:\Municipalities\Municipal Standard Construction Documents\South Whitehall Township\Working Documents\SWT-REC-01.dwg Printed: Mar 22, 2017 - 4:03pm

NOTES:

1. TRAIL MAY BE REQUIRED TO BE ILLUMINATED TO TOWNSHIP STANDARDS.
2. TRAIL SHALL HAVE A CROSS SLOPE OF TWO (2) PERCENT AND A MAXIMUM LONGITUDINAL SLOPE OF FIVE (5) PERCENT.
3. A TURFED AREA SHALL BE MAINTAINED 3 FEET ON EACH SIDE OF THE 10-FOOT WIDE TRAIL.
4. GUIDE RAIL OR OTHER SUITABLE PROTECTIVE BARRIER SHALL BE INSTALLED AT THE EDGE OF RIGHT-OF-WAY AS DETERMINED BY THE TOWNSHIP.

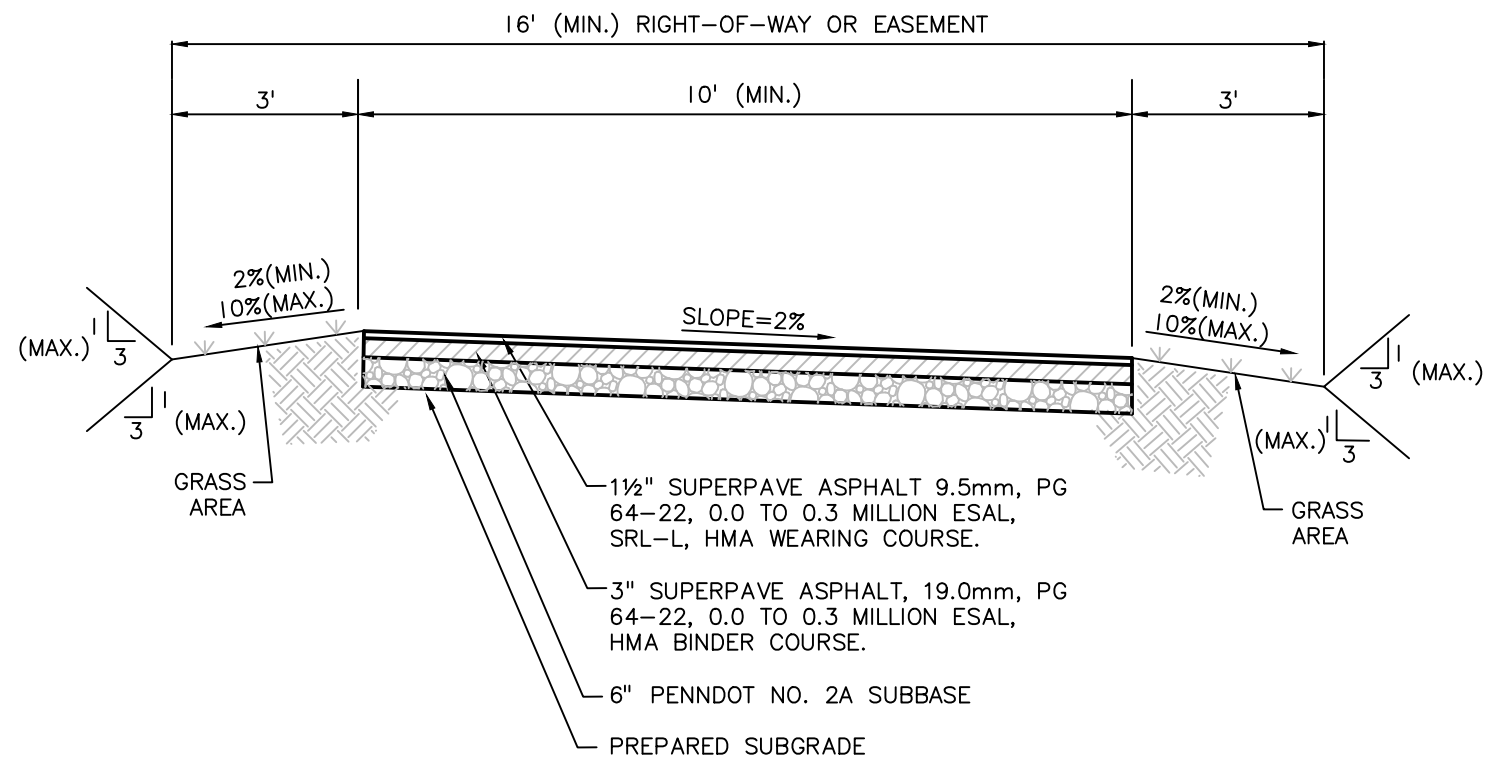

TRAIL CROSS SECTION
NO SCALE

REVISIONS	SOUTH WHITEHALL TOWNSHIP STANDARD CONSTRUCTION DETAILS LEHIGH COUNTY, PENNSYLVANIA
	RECREATIONAL FACILITIES RECREATIONAL TRAIL
	THE PIDCOCK COMPANY CIVIL ENGINEERING AND LAND PLANNING ARCHITECTURE LAND SURVEYING OXFORD DRIVE AT FISH HATCHERY ROAD ALLENTOWN, PENNSYLVANIA
	DATE: MARCH 2017 CHKD BY: RJK SCALE: NO SCALE SWT-REC-1

Drawing name: S:\Municipalities\Municipal Standard Construction Documents\South Whitehall Township\Working Documents\SWT-S-01.dwg Printed: Mar 22, 2017 4:03pm

CAUTION:

WHEN PIPING SYSTEMS ARE PRESSURE TESTED, IT IS EXTREMELY IMPORTANT AND ESSENTIAL THAT ALL PLUGS INCLUDING TEST PLUGS AND ALL PIPE JOINTS ARE INSTALLED AND RESTRAINED IN SUCH A WAY THAT BLOWOUTS ARE PREVENTED. IT MUST BE REALIZED THAT SUDDEN EXPULSION OF A POORLY INSTALLED PLUG OR SECTION OF PIPE OR OF A TEST PLUG WHICH IS PARTIALLY DEFLATED BEFORE THE PIPE PRESSURE IS RELEASED CAN BE VERY DANGEROUS. FOR THIS REASON IT IS RECOMMENDED THAT EVERY PLUG AND PIPE JOINT BE POSITIVELY BRACED OR OTHERWISE RESTRAINED DURING PRESSURE TESTING AND THAT NO ONE BE ALLOWED IN A MANHOLE ADJOINING A LINE BEING TESTED OR IN THE VICINITY OF AN EXPOSED PLUG OR PIPE SO LONG AS PRESSURE IS MAINTAINED IN THE LINE.

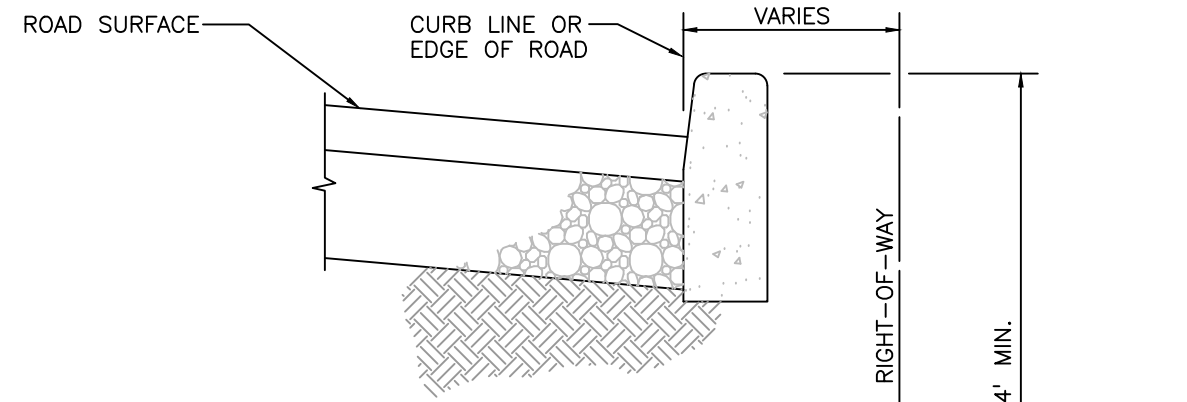

NOTE:

WARNING TAPE SHALL BE PLACED AT A MINIMUM 2 FT. ABOVE ANY MAINLINE PIPE OR LATERAL.

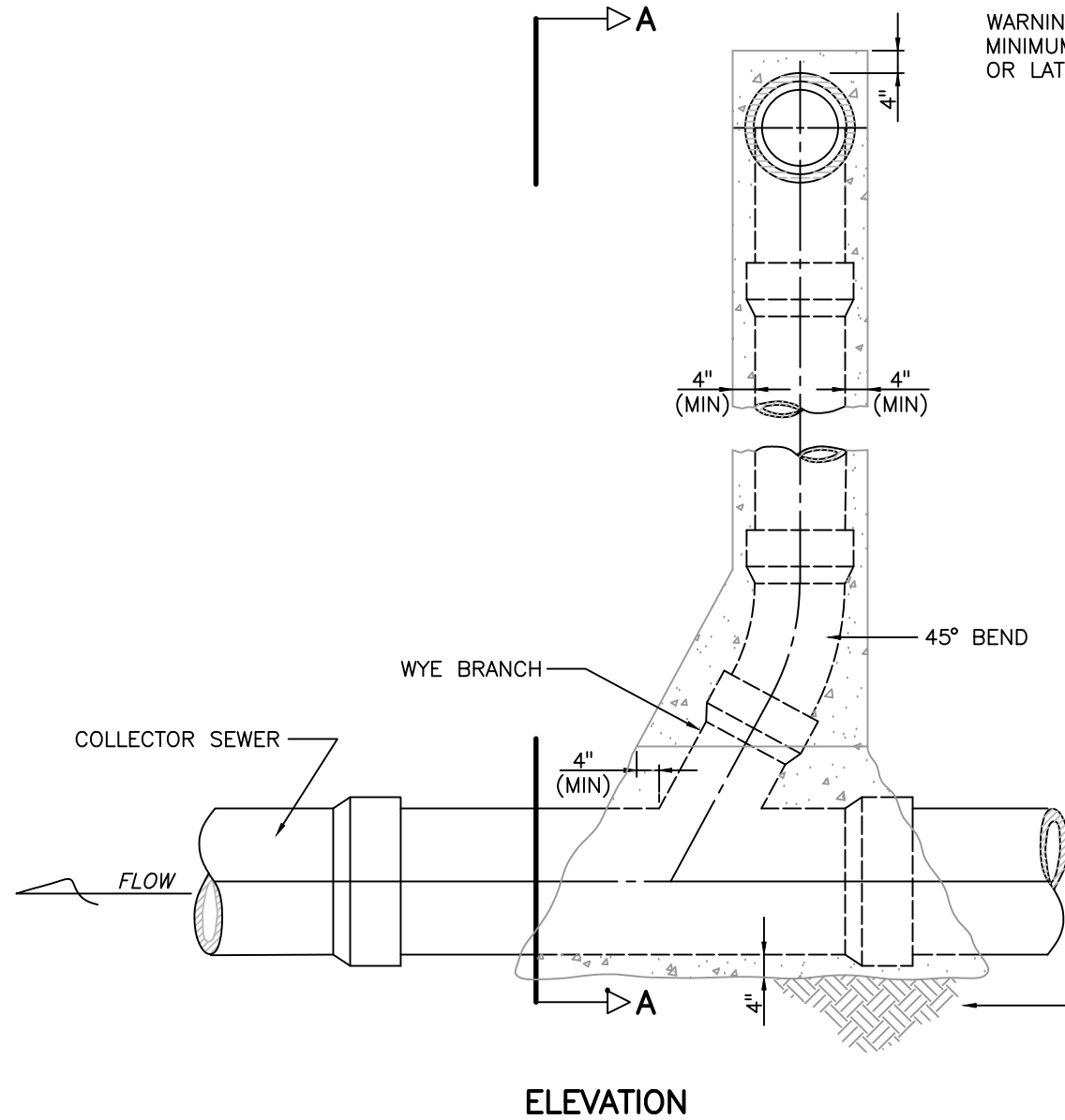

ELEVATION

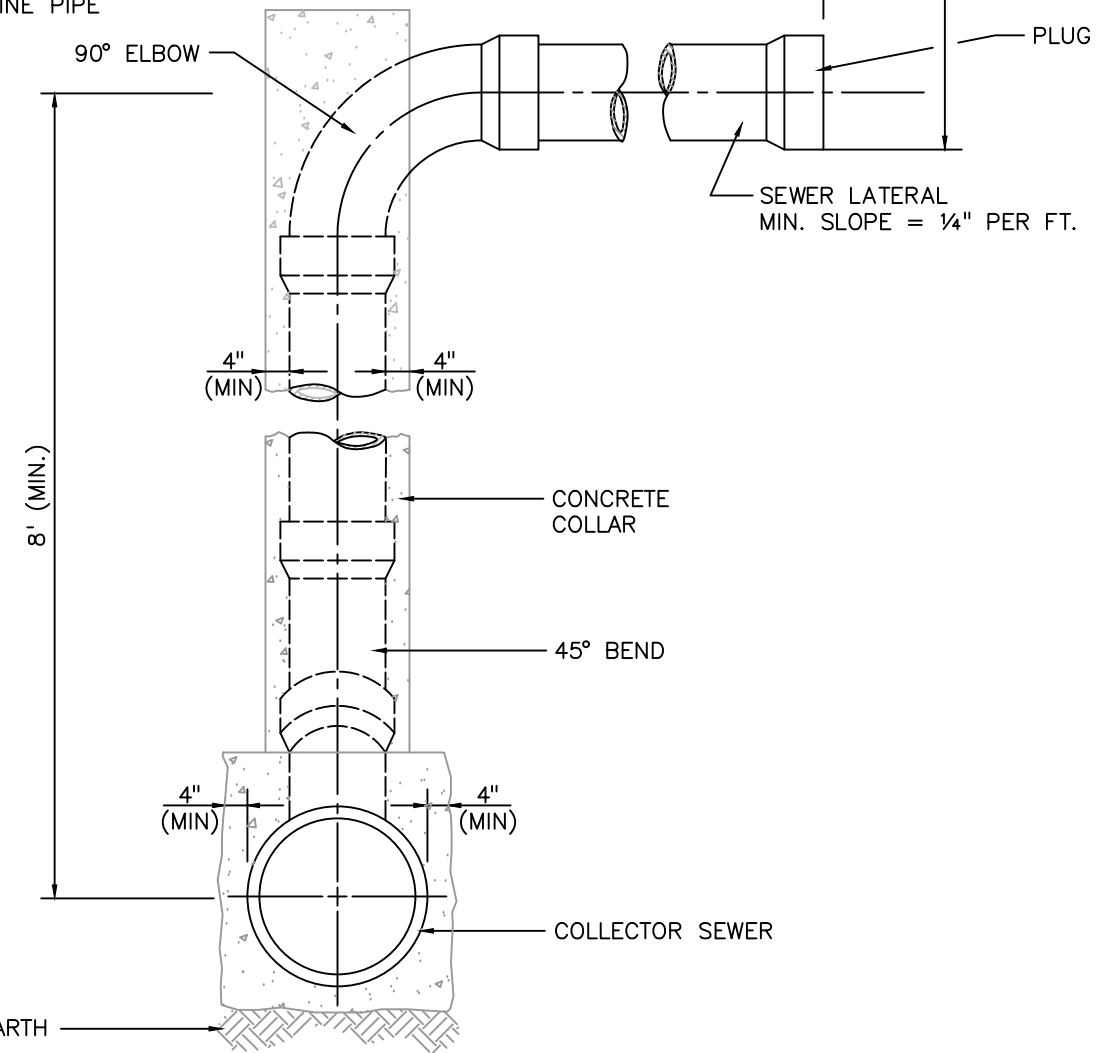

SECTION A-A

**TYPICAL SERVICE CONNECTION
DEEP SEWER**

NO SCALE

REVISIONS	SOUTH WHITEHALL TOWNSHIP AUTHORITY STANDARD CONSTRUCTION DETAILS LEHIGH COUNTY, PENNSYLVANIA	
	SANITARY SEWER TYPICAL SERVICE CONNECTION DEEP SEWER	
	THE PIDCOCK COMPANY CIVIL ENGINEERING AND LAND PLANNING ARCHITECTURE LAND SURVEYING	
	DATE: MARCH 2017	CHKD BY: SRH
	SCALE: NO SCALE	SWT-S-1

Drawing name: S:\Municipalities\Municipal Standard Construction Documents\South Whitehall Township\Working Documents\SWT-S-02.dwg Printed: Mar 22, 2017 4:03pm

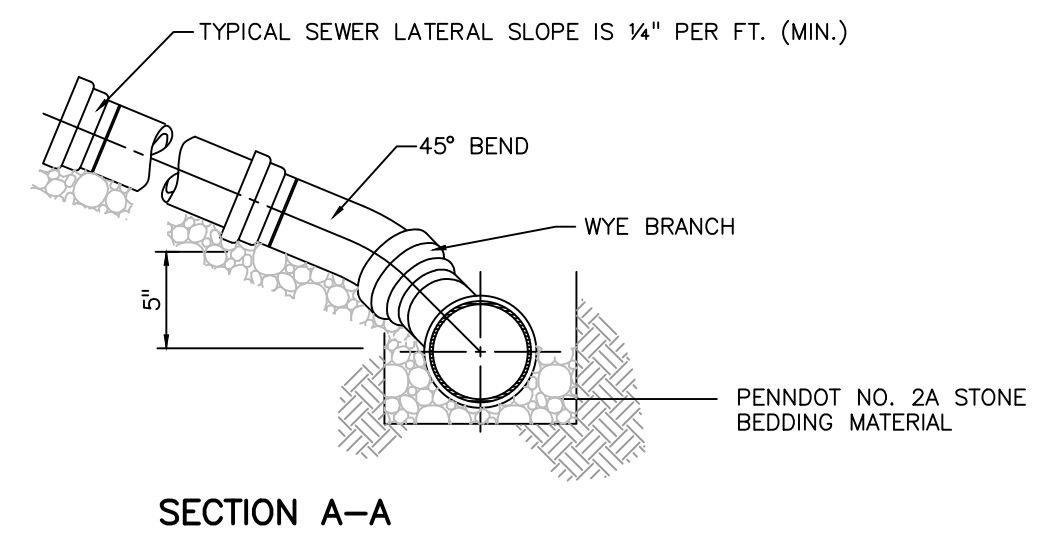
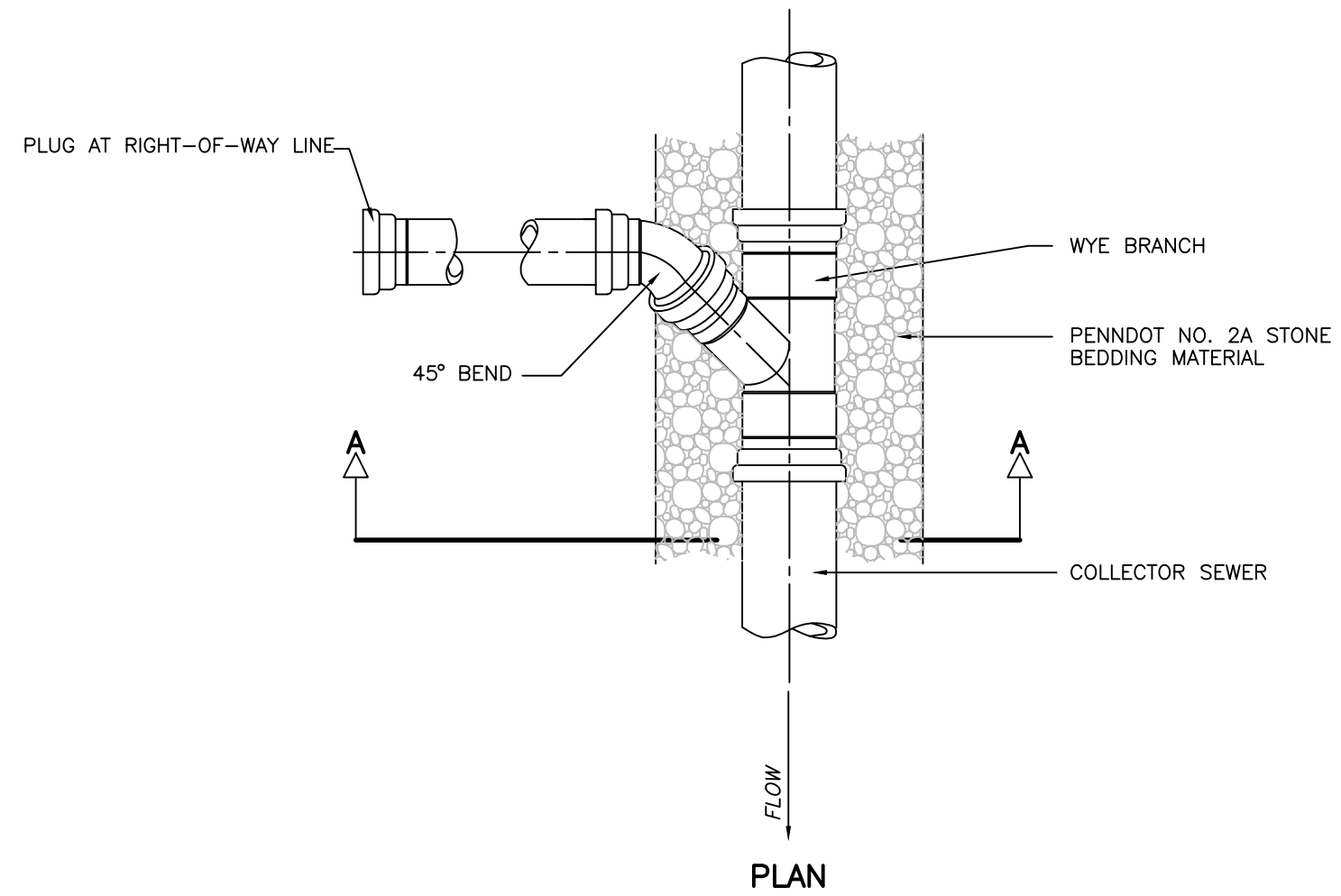

NOTES:

1. NORMAL INSTALLATION OF SANITARY SEWER SERVICE LATERAL SHALL BE A MINIMUM OF 8 FEET BELOW THE TOP OF CURB OR OUTSIDE EDGE OF SHOULDER.
2. WARNING TAPE SHALL BE PLACED AT A MINIMUM OF 2 FT. ABOVE ANY MAINLINE PIPE OR LATERAL.

CAUTION:

WHEN PIPING SYSTEMS ARE PRESSURE TESTED, IT IS EXTREMELY IMPORTANT AND ESSENTIAL THAT ALL PLUGS INCLUDING TEST PLUGS AND ALL PIPE JOINTS ARE INSTALLED AND RESTRAINED IN SUCH A WAY THAT BLOWOUTS ARE PREVENTED. IT MUST BE REALIZED THAT SUDDEN EXPULSION OF A POORLY INSTALLED PLUG OR SECTION OF PIPE OR OF A TEST PLUG WHICH IS PARTIALLY DEFLATED BEFORE THE PIPE PRESSURE IS RELEASED CAN BE VERY DANGEROUS. FOR THIS REASON IT IS RECOMMENDED THAT EVERY PLUG AND PIPE JOINT BE POSITIVELY BRACED OR OTHERWISE RESTRAINED DURING PRESSURE TESTING AND THAT NO ONE BE ALLOWED IN A MANHOLE ADJOINING A LINE BEING TESTED OR IN THE VICINITY OF AN EXPOSED PLUG OR PIPE SO LONG AS PRESSURE IS MAINTAINED IN THE LINE.

TYPICAL SANITARY SERVICE CONNECTION

NO SCALE

REVISIONS	SOUTH WHITEHALL TOWNSHIP AUTHORITY STANDARD CONSTRUCTION DETAILS LEHIGH COUNTY, PENNSYLVANIA	
	SANITARY SEWER TYPICAL SANITARY SERVICE CONNECTION	
	THE PIDCOCK COMPANY <small>CIVIL ENGINEERING AND LAND PLANNING ARCHITECTURE LAND SURVEYING</small>	
	<small>DATE: MARCH 2017</small>	<small>CHKD BY: SRH</small>
<small>OXFORD DRIVE AT FISH HATCHERY ROAD ALLENTOWN, PENNSYLVANIA</small>		<small>SCALE: NO SCALE</small>
		SWT-S-2

Drawing name: S:\Municipalities\Municipal Standard Construction Documents\South Whitehall Township\SWT-S-03.dwg Printed: Mar 22, 2017 4:03pm

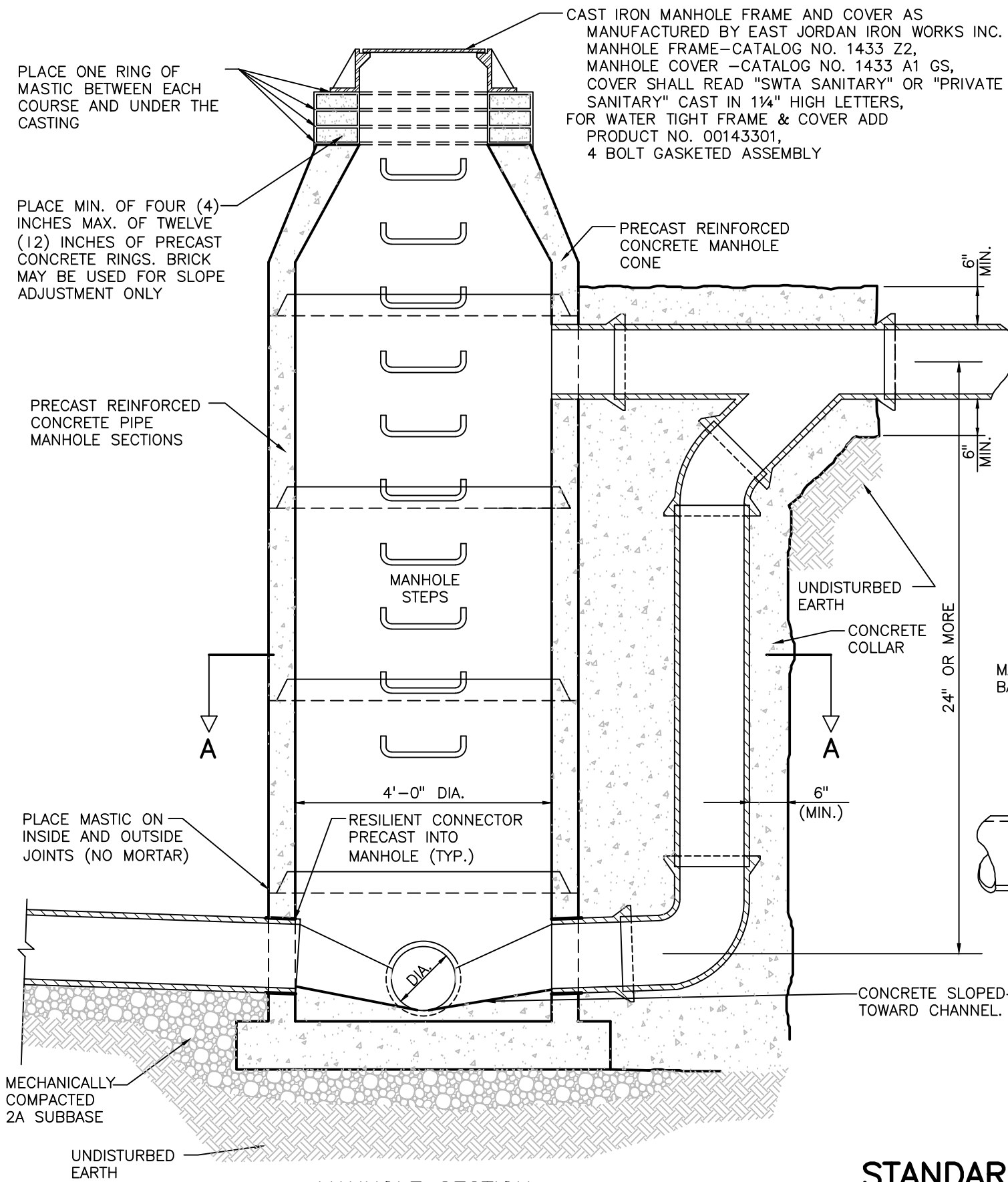

CAUTION:

WHEN PIPING SYSTEMS ARE PRESSURE TESTED, IT IS EXTREMELY IMPORTANT AND ESSENTIAL THAT ALL PLUGS INCLUDING TEST PLUGS AND ALL PIPE JOINTS ARE INSTALLED AND RESTRAINED IN SUCH A WAY THAT BLOWOUTS ARE PREVENTED. IT MUST BE REALIZED THAT SUDDEN EXPULSION OF A POORLY INSTALLED PLUG OR SECTION OF PIPE OR OF A TEST PLUG WHICH IS PARTIALLY DEFLATED BEFORE THE PIPE PRESSURE IS RELEASED CAN BE VERY DANGEROUS. FOR THIS REASON IT IS RECOMMENDED THAT EVERY PLUG AND PIPE JOINT BE POSITIVELY BRACED OR OTHERWISE RESTRAINED DURING PRESSURE TESTING AND THAT NO ONE BE ALLOWED IN A MANHOLE ADJOINING A LINE BEING TESTED OR IN THE VICINITY OF AN EXPOSED PLUG OR PIPE SO LONG AS PRESSURE IS MAINTAINED IN THE LINE.

NOTES:

1. A 12" CAST-IN-PLACE, REINFORCED BASE MAY BE USED FOR A "DOGHOUSE" TYPE MANHOLE.
2. PROVIDE FLEXIBLE GASKET IN MACHINED GROOVE IN LID.
3. PAINT ENTIRE OUTER SURFACE OF MANHOLE WITH ONE (1) COAT OF AN APPROVED BITUMASTIC MATERIAL.
4. THE INTERIOR SHALL BE COATED WITH FLEX-SEAL UTILITY SEALANT AS MANUFACTURED BY SEALING SYSTEMS, INC., TO COVER THE CASTING JOINT TO CONCRETE AND ANY PLASTERED AREA, FOLLOWING THE MANUFACTURER'S SPECIFICATIONS.
5. STEP DIMENSIONS AND CONFIGURATION SHALL BE IN ACCORDANCE WITH PENNDOT STANDARDS FOR ROADWAY CONSTRUCTION, CURRENT EDITION (PDT PUB #72M), RC-39M.
6. THE MANUFACTURER OF THE MANHOLES SHALL BE INCLUDED ON THE PENNDOT LIST OF APPROVED MANUFACTURERS OF PRECAST CONCRETE PRODUCTS (BULLETIN 15).
7. REFER TO PDT PUB #72M, RC-39M FOR ADDITIONAL REQUIREMENTS.

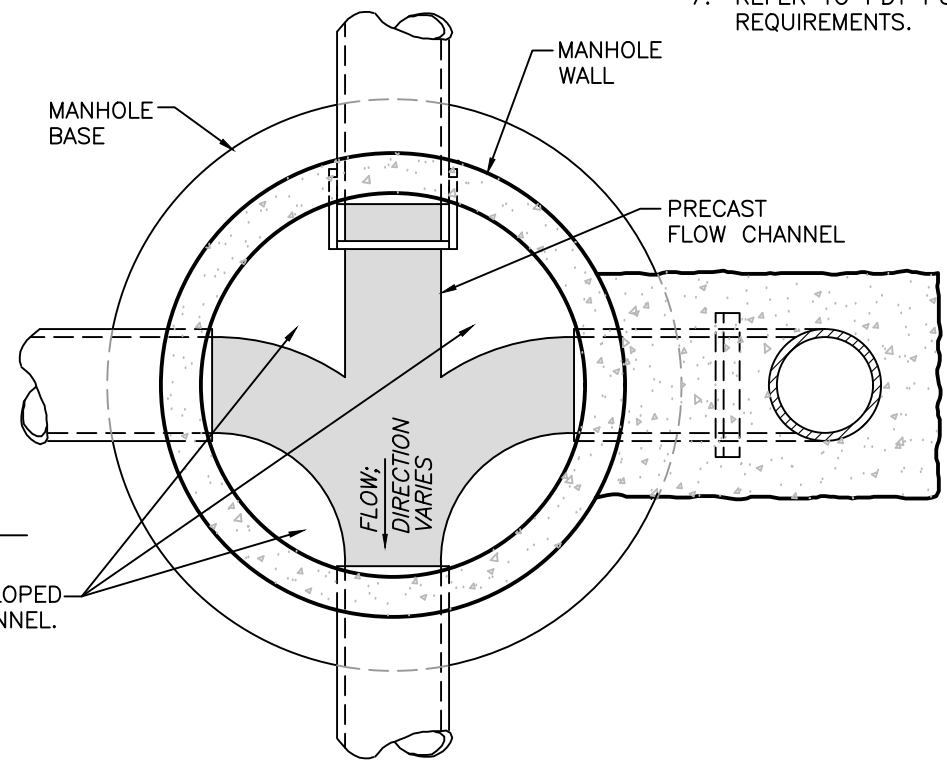

**STANDARD SANITARY
PRECAST CONCRETE PIPE
DROP MANHOLE**
NO SCALE

REVISIONS MARCH 31, 2016	SOUTH WHITEHALL TOWNSHIP AUTHORITY STANDARD CONSTRUCTION DETAILS LEHIGH COUNTY, PENNSYLVANIA	
	SANITARY SEWER PRECAST CONCRETE PIPE DROP MANHOLE	
THE PIDCOCK COMPANY <small>CIVIL ENGINEERING AND LAND PLANNING ARCHITECTURE LAND SURVEYING</small>		DATE: MARCH 2017 CHKD BY: SRH SCALE: NO SCALE
<small>OXFORD DRIVE AT FISH HATCHERY ROAD ALLENTOWN, PENNSYLVANIA</small>		SWT-S-3

Drawing name: S:\Municipalities\Municipal Standard Construction Documents\South Whitehall Township\SWT-WORKING DOCUMENTS\SWT-S-04.dwg Printed: Mar 22, 2017 4:03pm

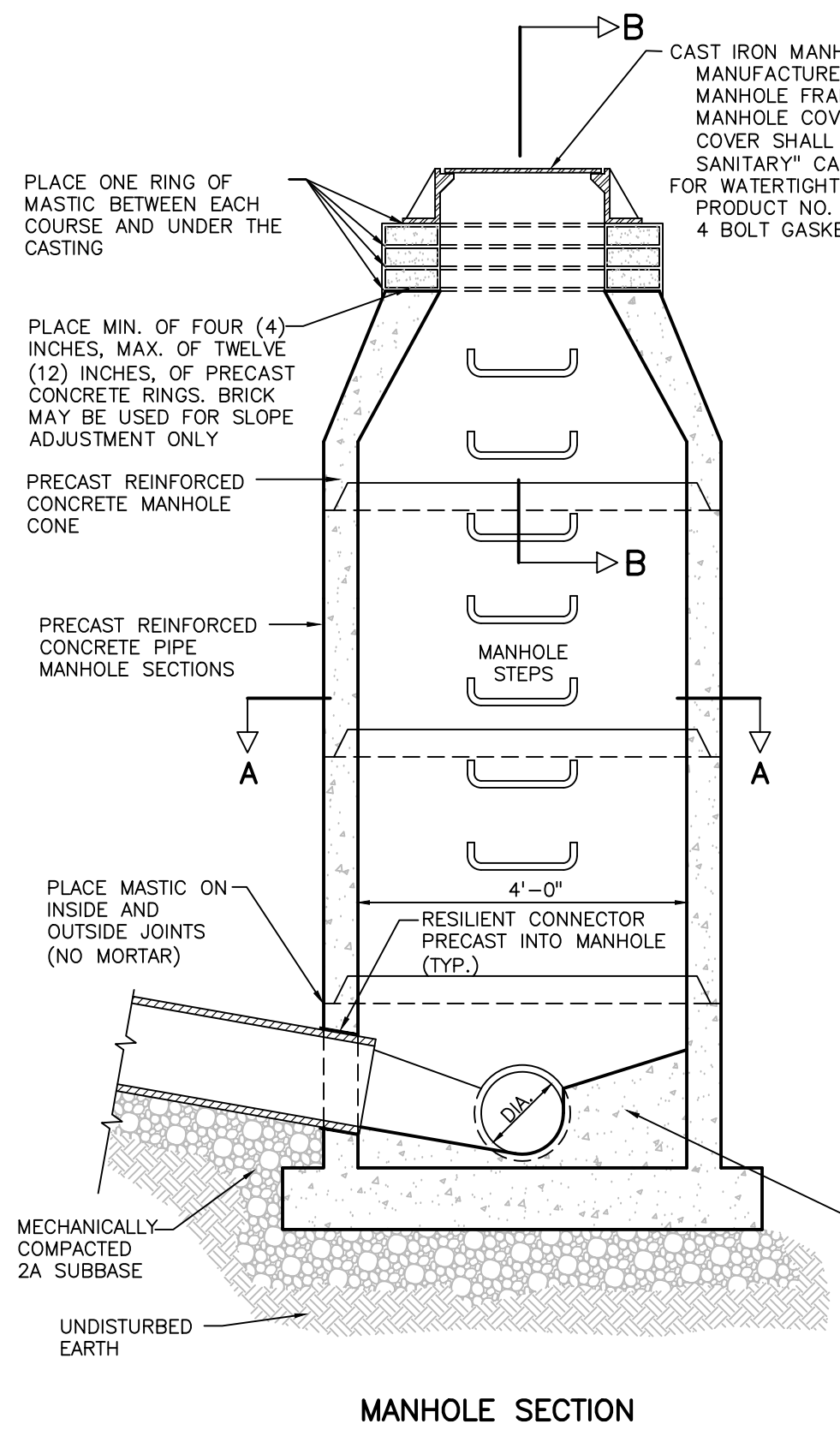

CAST IRON MANHOLE FRAME AND COVER AS MANUFACTURED BY EAST JORDAN IRON WORKS INC. MANHOLE FRAME-CATALOG NO. 1433 Z2, MANHOLE COVER -CATALOG NO. 1433 A1 GS, COVER SHALL READ "SWTA SANITARY" OR "PRIVATE SANITARY" CAST IN 1/4" HIGH LETTERS, FOR WATERTIGHT FRAME & COVER ADD PRODUCT NO. 00143301, 4 BOLT GASKETED ASSEMBLY

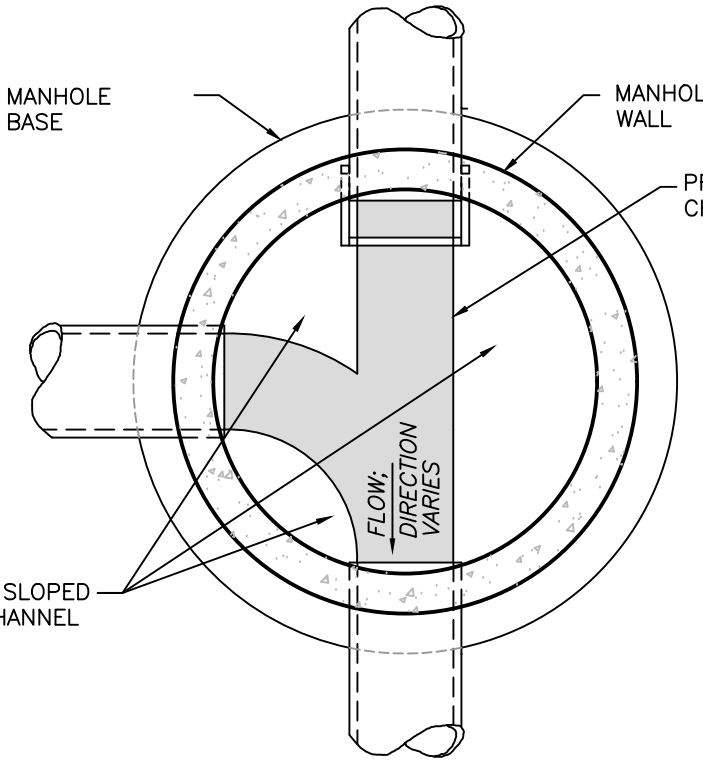
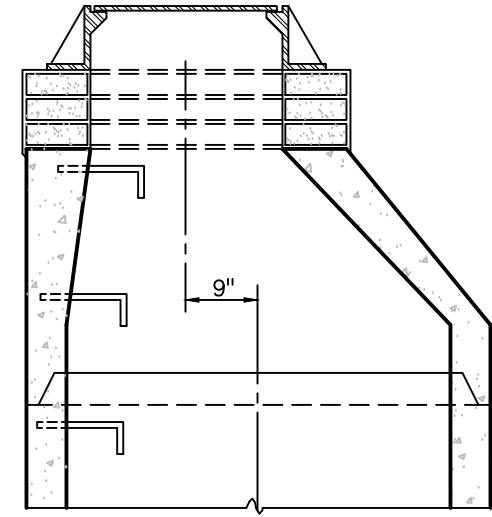

NOTES:

1. A 12" CAST-IN-PLACE, REINFORCED BASE MAY BE USED FOR A "DOGHOUSE" TYPE MANHOLE.
2. PROVIDE FLEXIBLE GASKET IN MACHINED GROOVE IN LID.
3. PAINT ENTIRE OUTER SURFACE OF MANHOLE WITH ONE (1) COAT OF AN APPROVED BITUMASTIC MATERIAL.
4. THE INTERIOR SHALL BE COATED WITH FLEX-SEAL UTILITY SEALANT AS MANUFACTURED BY SEALING SYSTEMS, INC., TO COVER THE CASTING JOINT TO CONCRETE AND ANY PLASTERED AREA, FOLLOWING THE MANUFACTURER'S SPECIFICATIONS.
5. STEP DIMENSIONS AND CONFIGURATION SHALL BE IN ACCORDANCE WITH PENNDOT STANDARDS FOR ROADWAY CONSTRUCTION, CURRENT EDITION (PDT PUB #72M), RC-39M.
6. THE MANUFACTURER OF THE MANHOLES SHALL BE INCLUDED ON THE PENNDOT LIST OF APPROVED MANUFACTURERS OF PRECAST CONCRETE PRODUCTS (BULLETIN 15).
7. REFER TO PDT PUB #72M, RC-39M FOR ADDITIONAL REQUIREMENTS.

CAUTION:

WHEN PIPING SYSTEMS ARE PRESSURE TESTED, IT IS EXTREMELY IMPORTANT AND ESSENTIAL THAT ALL PLUGS INCLUDING TEST PLUGS AND ALL PIPE JOINTS ARE INSTALLED AND RESTRAINED IN SUCH A WAY THAT BLOWOUTS ARE PREVENTED. IT MUST BE REALIZED THAT SUDDEN EXPULSION OF A POORLY INSTALLED PLUG OR SECTION OF PIPE OR OF A TEST PLUG WHICH IS PARTIALLY DEFLATED BEFORE THE PIPE PRESSURE IS RELEASED CAN BE VERY DANGEROUS. FOR THIS REASON IT IS RECOMMENDED THAT EVERY PLUG AND PIPE JOINT BE POSITIVELY BRACED OR OTHERWISE RESTRAINED DURING PRESSURE TESTING AND THAT NO ONE BE ALLOWED IN A MANHOLE ADJOINING A LINE BEING TESTED OR IN THE VICINITY OF AN EXPOSED PLUG OR PIPE SO LONG AS PRESSURE IS MAINTAINED IN THE LINE.

STANDARD SANITARY PRECAST CONCRETE PIPE MANHOLE
NO SCALE

REVISIONS	SOUTH WHITEHALL TOWNSHIP AUTHORITY STANDARD CONSTRUCTION DETAILS LEHIGH COUNTY, PENNSYLVANIA	
	SANITARY SEWER STANDARD PRECAST CONCRETE PIPE MANHOLE	
	THE PIDCOCK COMPANY <small>CIVIL ENGINEERING AND LAND PLANNING ARCHITECTURE LAND SURVEYING</small>	
	<small>DATE: MARCH 2017</small>	<small>CHKD BY: SRH</small>
	<small>SCALE: NO SCALE</small>	
	<small>OXFORD DRIVE AT FISH HATCHERY ROAD ALLENTOWN, PENNSYLVANIA</small>	
	SWT-S-4	

Drawing name: S:\Municipalities\MUNICIPAL STANDARD CONSTRUCTION DOCUMENTS\SOUTH WHITEHALL TOWNSHIP\SWT-WORKING DOCUMENTS\SWT-S-05.dwg Printed: Mar 22, 2017 - 4:03pm

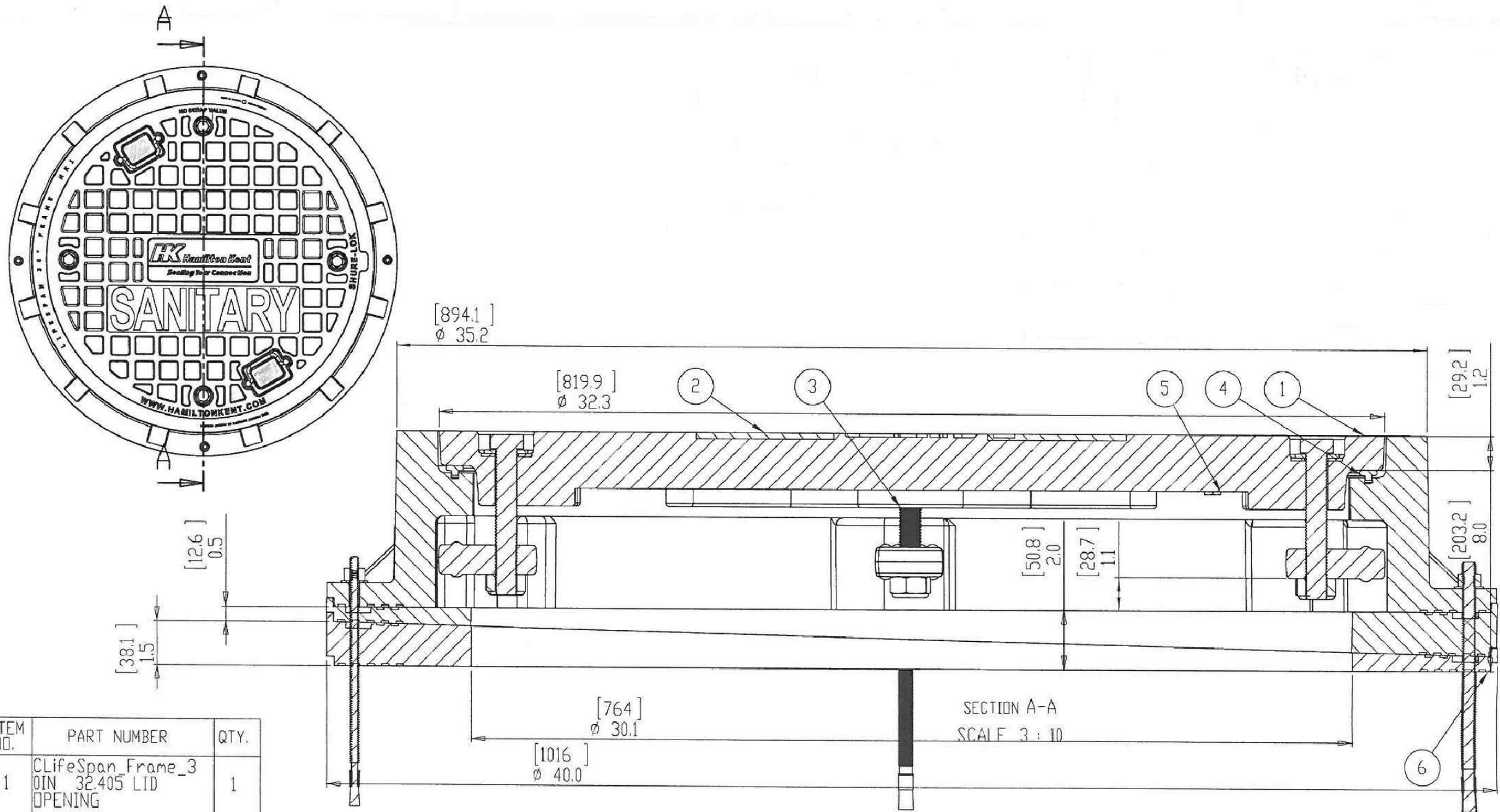

ITEM NO.	PART NUMBER	QTY.
1	ClifeSpan Frame_3 30IN 32.405 LTD OPENING	1
2	C30 PLATE	1
3	LUG ASSY.	4
4	GASKET 30 MUSHROOM STYLE	1
5	CHANDLE ASS-1VER 2	2
6	Clifespan angled grade ring30id	2
7	1-2 X 7 ANCHOR BOLT	4

NOTE: FOR INSTALLATION ON MANHOLES IN AREAS PRONE TO FLOODING IF REQUIRED BY THE TOWNSHIP

**HAMILTON KENT INC.
LIFESPAN 30" DIA. ASSEMBLY WITH
COMPOSITE COVER**

NO SCALE

REVISIONS	SOUTH WHITEHALL TOWNSHIP AUTHORITY STANDARD CONSTRUCTION DETAILS LEHIGH COUNTY, PENNSYLVANIA	
	SANITARY SEWER HAMILTON KENT INC. LIFESPAN 30" DIA. ASSEMBLY WITH COMPOSITE COVER	
	THE PIDCOCK COMPANY CIVIL ENGINEERING AND LAND PLANNING ARCHITECTURE LAND SURVEYING OXFORD DRIVE AT FISH HATCHERY ROAD ALLENTOWN, PENNSYLVANIA	
	DATE: MARCH 2017 CHKD BY: SRH SCALE: NO SCALE	

SWT-S-5

Drawing name: S:\Municipalities\Municipal Standard Construction Documents\South Whitehall Township\Working Documents\SWT-W-01.dwg Printed: Mar 22, 2017 4:03pm

NOTES:

1. TEES AND ELBOWS SHALL BE BLOCKED WITH CONCRETE AS SHOWN. PIPING SHALL BE HARNESSSED WITH RETAINER GLANDS AND TIE RODS.
2. A HYDRANT TEE MAY BE USED IN PLACE OF RODS TO SECURE THE VALVE, AS REVIEWED BY THE TOWNSHIP ON A CASE BY CASE BASIS.
3. WARNING TAPE SHALL BE PLACED AT A MINIMUM 2 FT. ABOVE ANY MAINLINE PIPE OR LATERAL.
4. DETAIL APPLICABLE FOR PRESSURES 100 PSI OR LOWER. WHERE PRESSURES ARE IN EXCESS OF 100 PSI, A SEPARATE SUBMISSION IS REQUIRED FOR REVIEW.

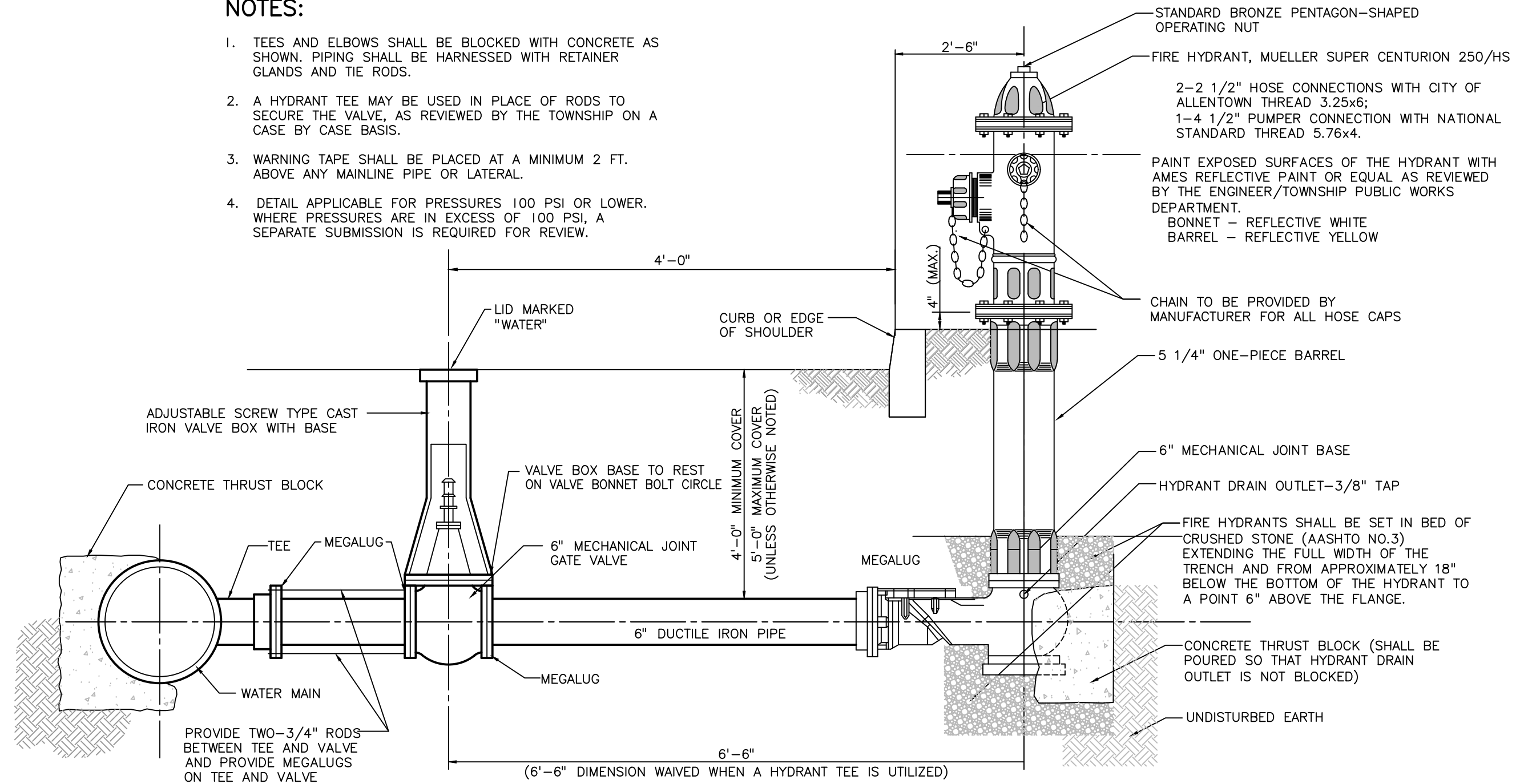

CAUTION:

WHEN PIPING SYSTEMS ARE PRESSURE TESTED, IT IS EXTREMELY IMPORTANT AND ESSENTIAL THAT ALL PLUGS INCLUDING TEST PLUGS AND ALL PIPE JOINTS ARE INSTALLED AND RESTRAINED IN SUCH A WAY THAT BLOWOUTS ARE PREVENTED. IT MUST BE REALIZED THAT SUDDEN EXPULSION OF A POORLY INSTALLED PLUG OR SECTION OF PIPE OR OF A TEST PLUG WHICH IS PARTIALLY DEFLATED BEFORE THE PIPE PRESSURE IS RELEASED CAN BE VERY DANGEROUS. FOR THIS REASON IT IS RECOMMENDED THAT EVERY PLUG AND PIPE JOINT BE POSITIVELY BRACED OR OTHERWISE RESTRAINED DURING PRESSURE TESTING AND THAT NO ONE BE ALLOWED IN A MANHOLE ADJOINING A LINE BEING TESTED OR IN THE VICINITY OF AN EXPOSED PLUG OR PIPE SO LONG AS PRESSURE IS MAINTAINED IN THE LINE.

FIRE HYDRANT
NO SCALE

REVISIONS	SOUTH WHITEHALL TOWNSHIP AUTHORITY STANDARD CONSTRUCTION DETAILS LEHIGH COUNTY, PENNSYLVANIA	
	WATER DISTRIBUTION SYSTEM FIRE HYDRANT	
	THE PIDCOCK COMPANY <small>CIVIL ENGINEERING AND LAND PLANNING ARCHITECTURE LAND SURVEYING</small> OXFORD DRIVE AT FISH HATCHERY ROAD ALLENTOWN, PENNSYLVANIA	
	DATE: MARCH 2017 CHKD BY: SRH SCALE: NO SCALE	SWT-W-1

Drawing name: S:\Municipalities\Municipal Standard Construction Documents\South Whitehall Township\SWT-W-02.dwg Printed: Mar 22, 2017 4:03pm

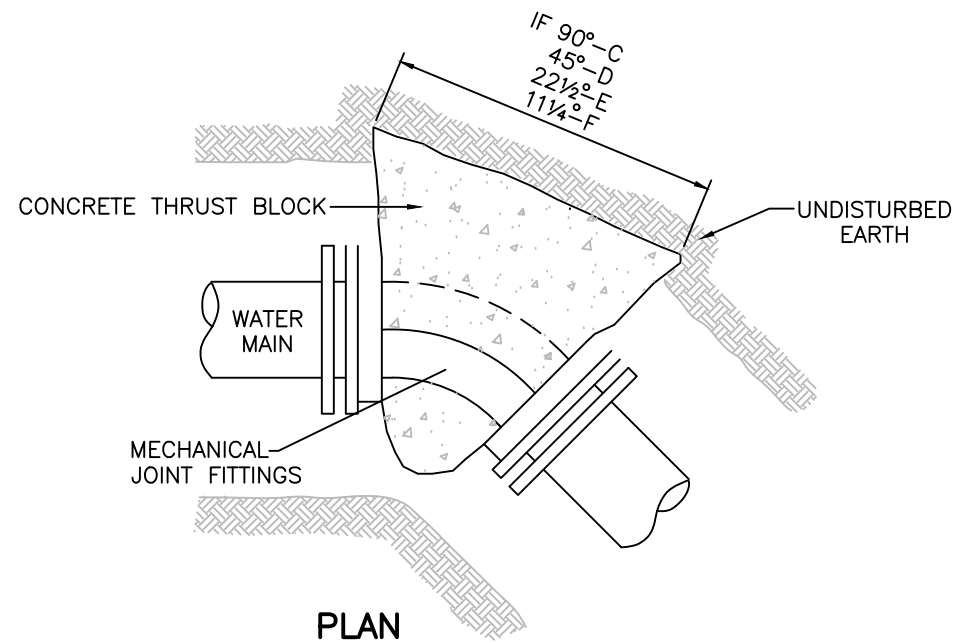

PLAN

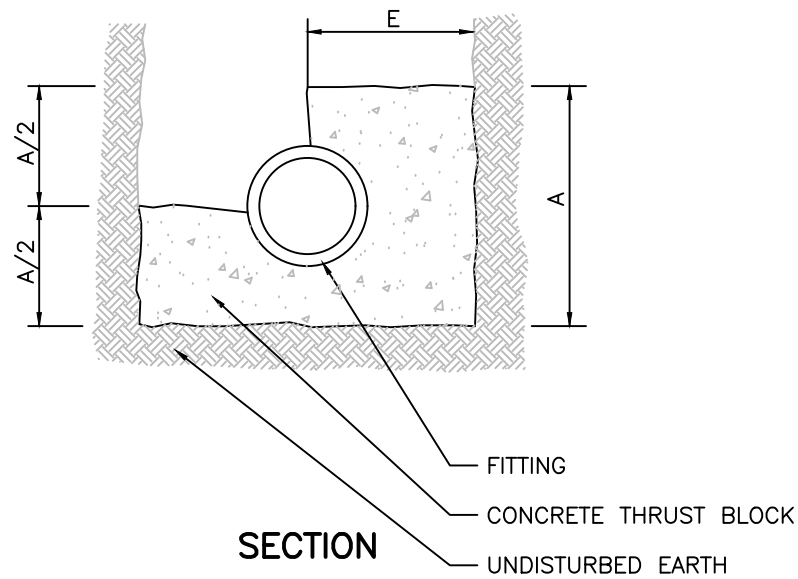

SECTION

HORIZONTAL BENDS

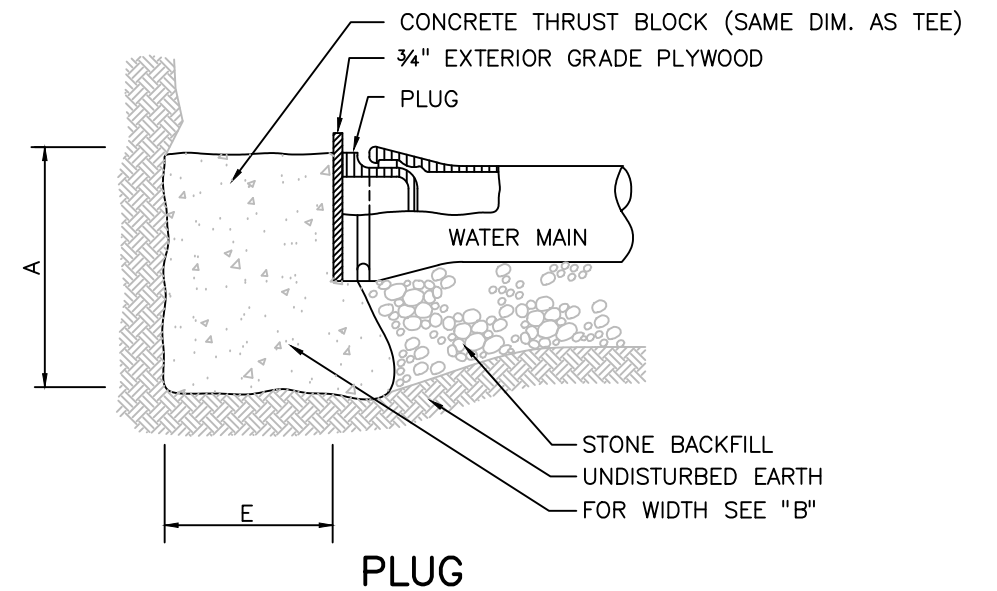

PLUG

NOTES:

1. CONCRETE THRUST BLOCKS SHALL NOT COVER MECHANICAL JOINTS, NUTS OR BOLTS.
2. PLACE BOND BREAKER BETWEEN PIPE AND CONCRETE (TYP.).
3. ALL JOINTS SHALL BE RESTRAINED WITH MEGALUGS.
4. DETAIL APPLICABLE FOR PRESSURES 100 PSI OR LOWER. WHERE PRESSURES ARE IN EXCESS OF 100 PSI, A SEPARATE SUBMISSION IS REQUIRED FOR REVIEW.

PIPE SIZE	TABLE OF REACTION BACKING MINIMUM DIMENSIONS					
	A	B	C	D	E	F
24"	4'-6"	7'-2"	8'-10"	5'-9"	3'-0"	1'-1"
20"	4'-0"	6'-8"	8'-4"	5'-3"	2'-6"	1'-5"
16"	3'-4"	5'-5"	7'-10"	4'-3"	2'-1"	1'-3"
10"-12"	2'-6"	4'-3"	6'-0"	3'-3"	1'-7"	1'-0"
8"	1'-8"	3'-0"	4'-3"	2'-4"	1'-2"	1'-0"
6"	1'-3"	2'-2"	3'-4"	1'-10"	1'-0"	1'-0"
3"	1'-0"	2'-0"	3'-0"	1'-6"	1'-0"	1'-0"

THRUST BLOCK DIMENSIONS FOR PIPE 20" AND LARGER ARE APPLICABLE ONLY TO PRESSURE BELOW 100 PSI.

DESIGN CALCULATIONS SHALL BE PROVIDED FOR ANY OTHER SIZES NOT LISTED.

DIMENSIONS IDENTIFIED ABOVE ARE MINIMUM REQUIREMENTS. THE DESIGN ENGINEER SHALL REVIEW THE ADEQUACY OF THE NOTED DIMENSIONS AND INCREASE DIMENSIONS AS NEEDED BASED ON THE SPECIFIC SITE DESIGN CONDITIONS.

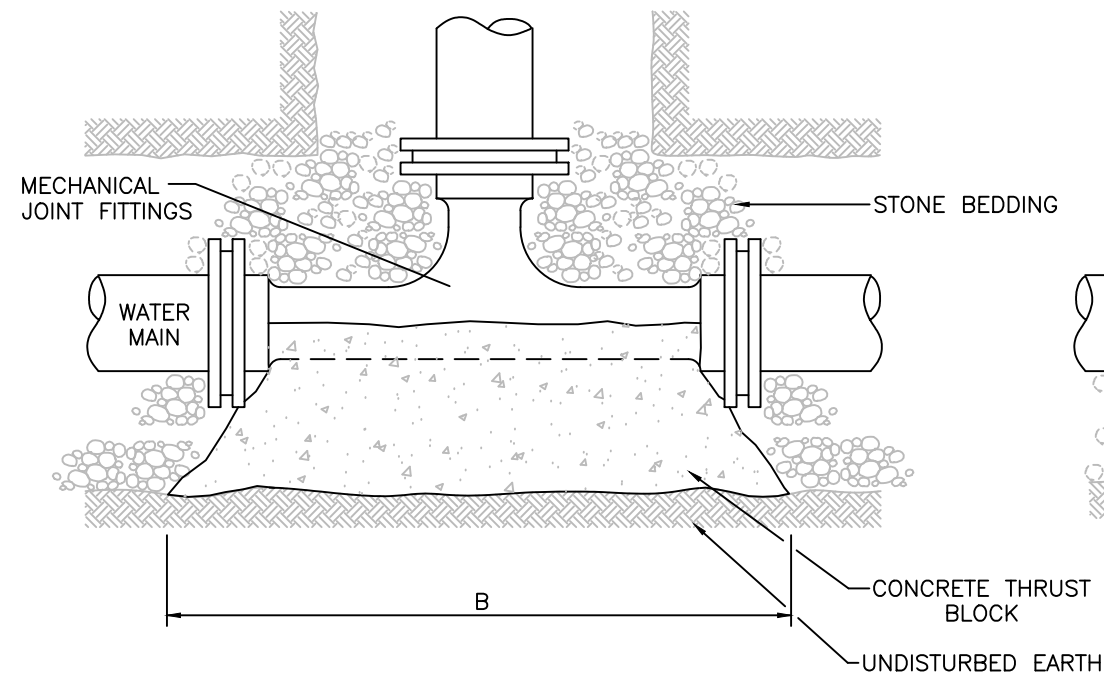

PLAN

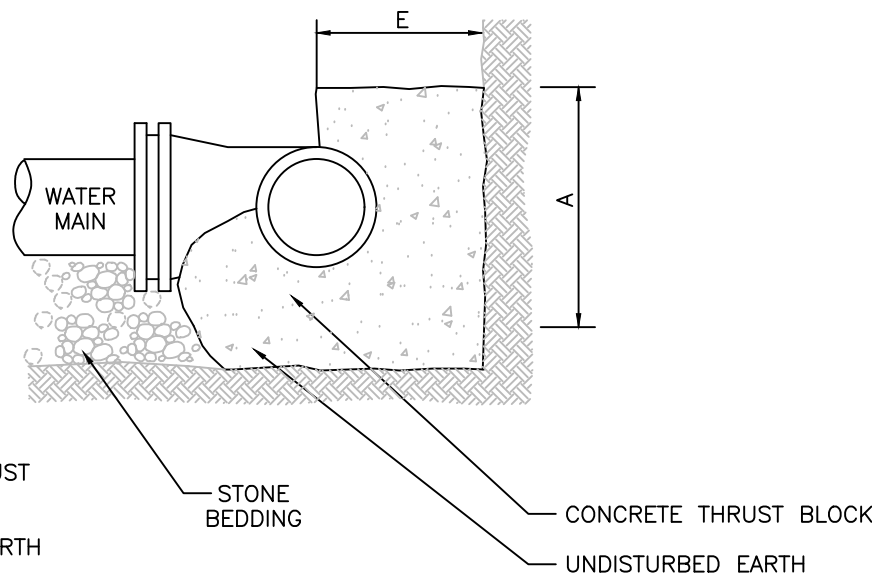

SECTION

TEE

CAUTION:

WHEN PIPING SYSTEMS ARE PRESSURE TESTED, IT IS EXTREMELY IMPORTANT AND ESSENTIAL THAT ALL PLUGS INCLUDING TEST PLUGS AND ALL PIPE JOINTS ARE INSTALLED AND RESTRAINED IN SUCH A WAY THAT BLOWOUTS ARE PREVENTED. IT MUST BE REALIZED THAT SUDDEN EXPULSION OF A POORLY INSTALLED PLUG OR SECTION OF PIPE OR OF A TEST PLUG WHICH IS PARTIALLY DEFLATED BEFORE THE PIPE PRESSURE IS RELEASED CAN BE VERY DANGEROUS. FOR THIS REASON IT IS RECOMMENDED THAT EVERY PLUG AND PIPE JOINT BE POSITIVELY BRACED OR OTHERWISE RESTRAINED DURING PRESSURE TESTING AND THAT NO ONE BE ALLOWED IN A MANHOLE ADJOINING A LINE BEING TESTED OR IN THE VICINITY OF AN EXPOSED PLUG OR PIPE SO LONG AS PRESSURE IS MAINTAINED IN THE LINE.

HORIZONTAL THRUST BLOCKS
NO SCALE

REVISIONS	SOUTH WHITEHALL TOWNSHIP AUTHORITY STANDARD CONSTRUCTION DETAILS LEHIGH COUNTY, PENNSYLVANIA	
	WATER DISTRIBUTION SYSTEM HORIZONTAL THRUST BLOCKS	
	THE PIDCOCK COMPANY CIVIL ENGINEERING AND LAND PLANNING ARCHITECTURE LAND SURVEYING OXFORD DRIVE AT FISH HATCHERY ROAD ALLENTOWN, PENNSYLVANIA	DATE: MARCH 2017 CHKD BY: SRH SCALE: NO SCALE
		SWT-W-2

Drawing name: S:\Municipalities\Municipal Standard Construction Documents\South Whitehall Township\Working Documents\SWT-W-03.dwg Printed: Mar 22, 2017 4:03pm

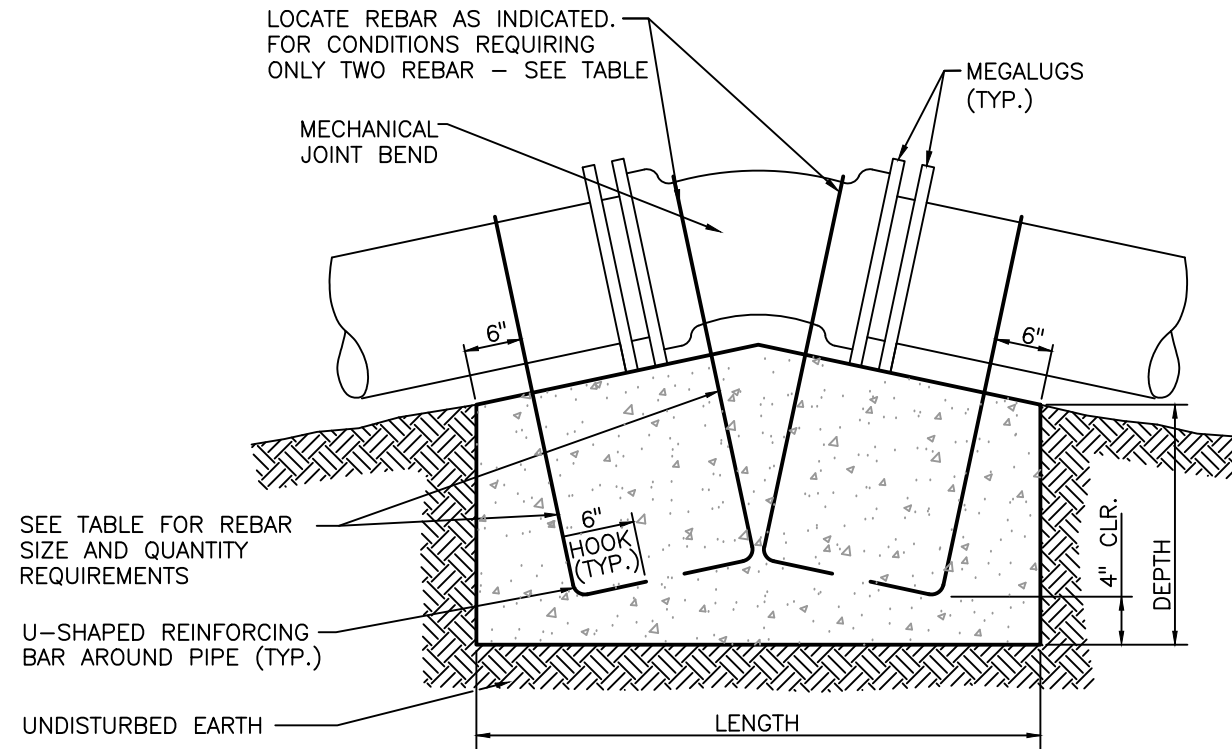

VERTICAL BEND DOWNWARD

PIPE SIZES	LENGTH			WIDTH			DEPTH			REBARS		
	11¼°	22½°	45°	11¼°	22½°	45°	11¼°	22½°	45°	11¼°	22½°	45°
4", 6" & 8"	3'	4'	6'	3'	3'	3'	2'	3'	4'	2-#4	2-#4	2-#5
12"	4.5'	6'	8'	3'	3'	4'	3'	4.5'	5'	2-#4	2-#6	3-#6
16"	6'	8'	11'	3.5'	3.5'	5'	3.5'	5'	5'	2-#5	4-#5	6-#6
20"	7'	9'	13'	4'	5'	5.5'	4'	5'	6'	3-#5	6-#5	6-#7

DESIGN CALCULATIONS SHALL BE PROVIDED FOR ANY OTHER SIZES NOT LISTED.

DIMENSIONS IDENTIFIED ABOVE ARE MINIMUM REQUIREMENTS. THE DESIGN ENGINEER SHALL REVIEW THE ADEQUACY OF THE NOTED DIMENSIONS AND INCREASE DIMENSIONS AS NEEDED BASED ON THE SPECIFIC SITE DESIGN CONDITIONS.

CAUTION:

WHEN PIPING SYSTEMS ARE PRESSURE TESTED, IT IS EXTREMELY IMPORTANT AND ESSENTIAL THAT ALL PLUGS INCLUDING TEST PLUGS AND ALL PIPE JOINTS ARE INSTALLED AND RESTRAINED IN SUCH A WAY THAT BLOWOUTS ARE PREVENTED. IT MUST BE REALIZED THAT SUDDEN EXPULSION OF A POORLY INSTALLED PLUG OR SECTION OF PIPE OR OF A TEST PLUG WHICH IS PARTIALLY DEFLATED BEFORE THE PIPE PRESSURE IS RELEASED CAN BE VERY DANGEROUS. FOR THIS REASON IT IS RECOMMENDED THAT EVERY PLUG AND PIPE JOINT BE POSITIVELY BRACED OR OTHERWISE RESTRAINED DURING PRESSURE TESTING AND THAT NO ONE BE ALLOWED IN A MANHOLE ADJOINING A LINE BEING TESTED OR IN THE VICINITY OF AN EXPOSED PLUG OR PIPE SO LONG AS PRESSURE IS MAINTAINED IN THE LINE.

NOTE:

DETAIL APPLICABLE FOR PRESSURES 100 PSI OR LOWER. WHERE PRESSURES ARE IN EXCESS OF 100 PSI, A SEPARATE SUBMISSION IS REQUIRED FOR REVIEW.

VERTICAL THRUST BLOCKS

NO SCALE

REVISIONS	SOUTH WHITEHALL TOWNSHIP AUTHORITY STANDARD CONSTRUCTION DETAILS LEHIGH COUNTY, PENNSYLVANIA		
	WATER DISTRIBUTION SYSTEM VERTICAL THRUST BLOCKS		
	THE PIDCOCK COMPANY <small>CIVIL ENGINEERING AND LAND PLANNING ARCHITECTURE LAND SURVEYING</small>		
	<small>OXFORD DRIVE AT FISH HATCHERY ROAD ALLENTOWN, PENNSYLVANIA</small>		
	<small>DATE: MARCH 2017</small>	<small>CHKD BY: SRH</small>	<small>SCALE: NO SCALE</small>
	SWT-W-3		

Drawing name: S:\Municipalities\Municipal Standard Construction Documents\South Whitehall Township\SWT-W-04.dwg Printed: Mar 24, 2017 - 2:57pm

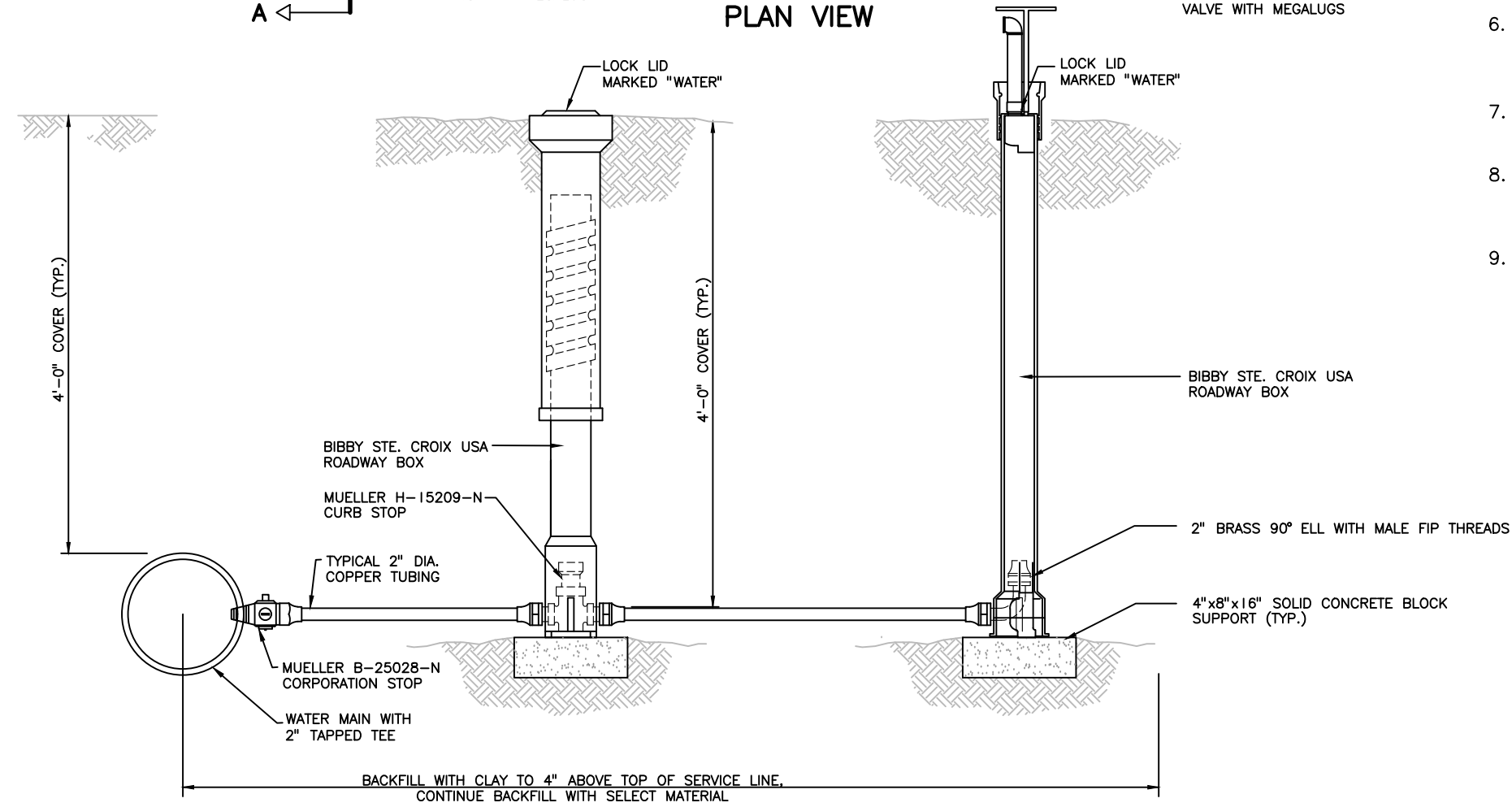
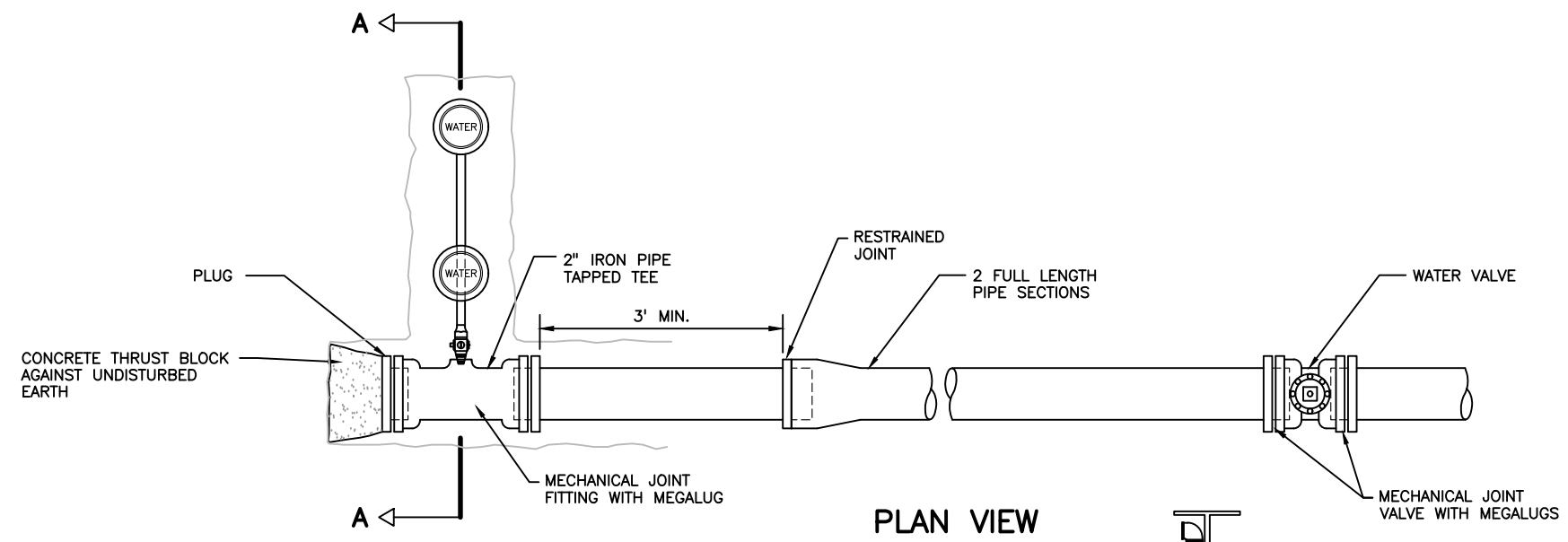

WATERLINE BLOW-OFF
NO SCALE

NOTES:

1. BLOWOFF SHALL BE ECLIPSE #TF500 AS MANUFACTURED BY KUPFERLE FOUNDRY, ST. LOUIS MO.
2. IF DIRECTED BY THE TOWNSHIP PUBLIC WORKS DEPARTMENT, THE BLOWOFF SHALL BE ECLIPSE #9900.
3. WHERE 2 FULL LENGTH PIPE SECTIONS CANNOT BE INSTALLED ON BLOW-OFF SIDE OF VALVE, HARNESS VALVE TO WATERLINE AND RESTRAIN JOINTS FOR 50 FEET ON SOURCE SIDE OF VALVE.
4. CORPORATION STOPS SHALL BE MUELLER B-25208-N, 2" DIA. WITH MALE IRON PIPE INLET CONNECTION AND COMPRESSION CONNECTION FOR THE OUTLET.
5. CURB STOPS SHALL BE MUELLER H-15209-N, 2" DIA. WITH COMPRESSION CONNECTIONS.
6. VALVE BOXES SHALL BE CAST IRON ADJUSTABLE SCREW TYPE BIBBY STE.CROIX USA 5 1/4" TWO-PIECE, ARCH BASE LOCKABLE LID.
7. AN 8" CLAY ENVELOPE SHALL BE PLACED AROUND ALL COPPER SERVICE LATERALS.
8. DETAIL APPLICABLE FOR PRESSURES 100 PSI OR LOWER. WHERE PRESSURES ARE IN EXCESS OF 100 PSI, A SEPARATE SUBMISSION IS REQUIRED FOR REVIEW.
9. ALL MATERIALS SHALL BE NSF CERTIFIED AND SHALL MEET THE LEAD (Pb) RESTRICTIONS CONTAINED IN FEDERAL BILL S-3874 (1/2014).

CAUTION:

WHEN PIPING SYSTEMS ARE PRESSURE TESTED, IT IS EXTREMELY IMPORTANT AND ESSENTIAL THAT ALL PLUGS INCLUDING TEST PLUGS AND ALL PIPE JOINTS ARE INSTALLED AND RESTRAINED IN SUCH A WAY THAT BLOWOUTS ARE PREVENTED. IT MUST BE REALIZED THAT SUDDEN EXPULSION OF A POORLY INSTALLED PLUG OR SECTION OF PIPE OR OF A TEST PLUG WHICH IS PARTIALLY DEFLATED BEFORE THE PIPE PRESSURE IS RELEASED CAN BE VERY DANGEROUS. FOR THIS REASON IT IS RECOMMENDED THAT EVERY PLUG AND PIPE JOINT BE POSITIVELY BRACED OR OTHERWISE RESTRAINED DURING PRESSURE TESTING AND THAT NO ONE BE ALLOWED IN A MANHOLE ADJOINING A LINE BEING TESTED OR IN THE VICINITY OF AN EXPOSED PLUG OR PIPE SO LONG AS PRESSURE IS MAINTAINED IN THE LINE.

REVISIONS	SOUTH WHITEHALL TOWNSHIP AUTHORITY STANDARD CONSTRUCTION DETAILS LEHIGH COUNTY, PENNSYLVANIA	
	WATER DISTRIBUTION SYSTEM WATERLINE BLOW-OFF	
	THE PIDCOCK COMPANY <small>CIVIL ENGINEERING AND LAND PLANNING ARCHITECTURE LAND SURVEYING</small>	
	<small>DATE: MARCH 2017</small>	<small>CHKD BY: SRH</small>
<small>OXFORD DRIVE AT FISH HATCHERY ROAD ALLENTOWN, PENNSYLVANIA</small>		SWT-W-4

Drawing name: S:\Municipalities\Municipal Standard Construction Documents\South Whitehall Township\SWT-W-05.dwg Printed: Mar 24, 2017 - 9:59am

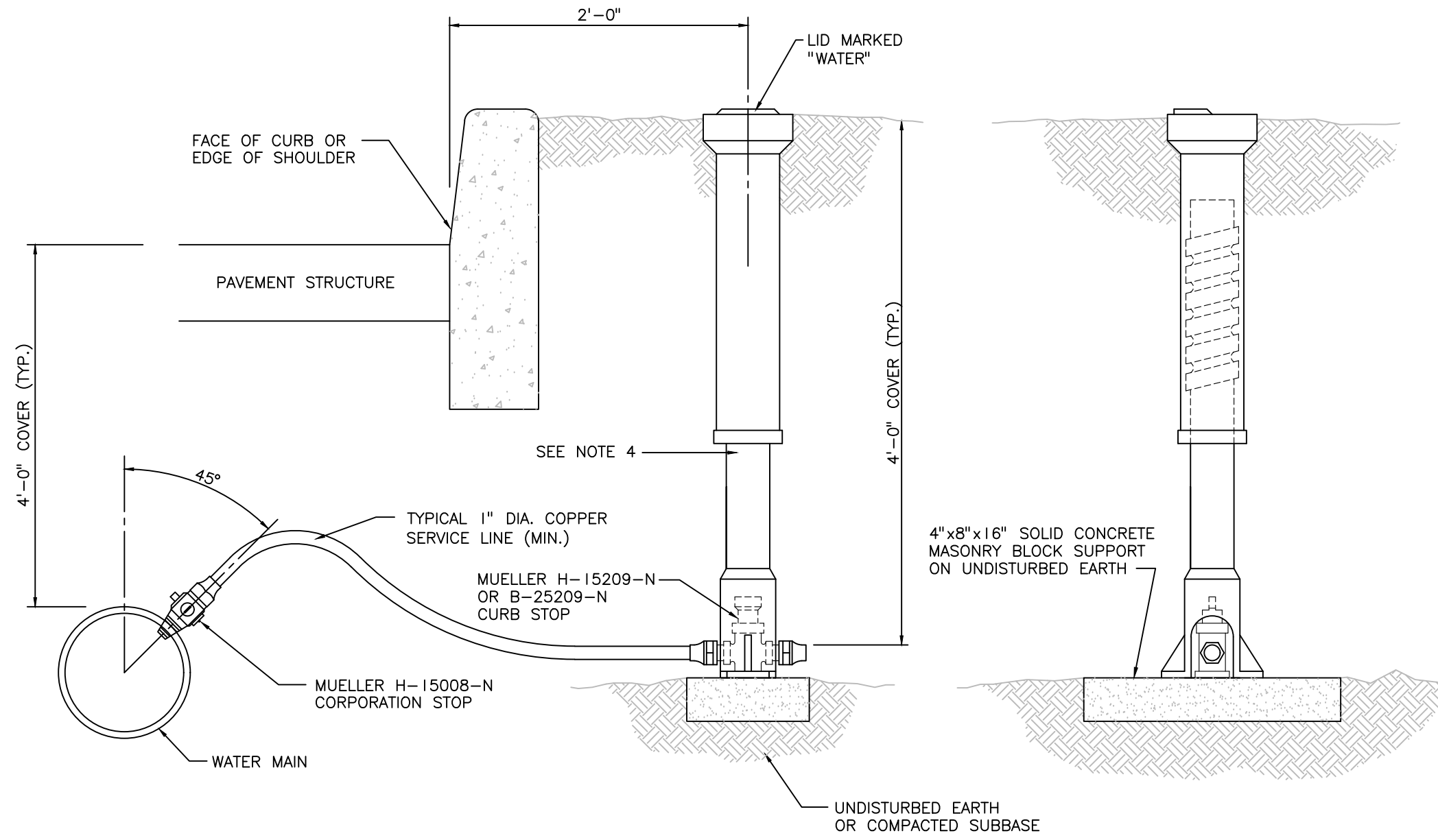

SIDE VIEW

FRONT VIEW

SERVICE CONNECTION

NO SCALE

CAUTION:

WHEN PIPING SYSTEMS ARE PRESSURE TESTED, IT IS EXTREMELY IMPORTANT AND ESSENTIAL THAT ALL PLUGS INCLUDING TEST PLUGS AND ALL PIPE JOINTS ARE INSTALLED AND RESTRAINED IN SUCH A WAY THAT BLOWOUTS ARE PREVENTED. IT MUST BE REALIZED THAT SUDDEN EXPULSION OF A POORLY INSTALLED PLUG OR SECTION OF PIPE OR OF A TEST PLUG WHICH IS PARTIALLY DEFLATED BEFORE THE PIPE PRESSURE IS RELEASED CAN BE VERY DANGEROUS. FOR THIS REASON IT IS RECOMMENDED THAT EVERY PLUG AND PIPE JOINT BE POSITIVELY BRACED OR OTHERWISE RESTRAINED DURING PRESSURE TESTING AND THAT NO ONE BE ALLOWED IN A MANHOLE ADJOINING A LINE BEING TESTED OR IN THE VICINITY OF AN EXPOSED PLUG OR PIPE SO LONG AS PRESSURE IS MAINTAINED IN THE LINE.

NOTES:

1. FOR SERVICE LINES LARGER THAN 1" A TAPPED TEE SHALL BE PROVIDED.
2. CORPORATION STOPS SHALL BE EQUAL TO MUELLER NO. B-25208 WITH MUELLER "CC" THREAD ON THE INLET AND COMPRESSION COUPLING FOR CONNECTION TO THE SERVICE LINE AT THE OUTLET END.
3. CURB STOPS SHALL BE EQUAL TO MUELLER MARK II, ORISEAL, NO. H-15209-N OR 300 BALL CURB VALVE, NO. B-25209-N, AND SHALL HAVE COMPRESSION COUPLINGS. VALVES SHALL BE QUARTER-TURN "CHECK" VALVE WITHOUT DRAIN, WITH COMPRESSION CONNECTION ON BOTH ENDS.
4. CURB BOXES WHICH ARE TO BE INSTALLED BEHIND CURBS SHALL BE CAST IRON, TWO-PIECE, ADJUSTABLE SCREW TYPE EQUAL TO TYLER 6500 SERIES WITH BASE AS RECOMMENDED BY MANUFACTURER. CURB BOXES WHICH ARE TO BE INSTALLED IN PAVED AND UNPAVED AREAS WHICH WILL BE ACCESSIBLE TO TRAFFIC SHALL BE CAST-IRON, THREE PIECE, ADJUSTABLE SCREW TYPE EQUAL TO TYLER 6860 SERIES, TYLER PIPE, TYLER, TX. CURB BOXES SHALL BE SET ON A BRICK OR MASONRY BLOCK FOUNDATION LAID ON UNDISTURBED EARTH OR COMPACTED SUBBASE.
5. AN 8" CLAY ENVELOPE SHALL BE PLACED AROUND ALL COPPER SERVICE LATERALS.
6. DETAIL APPLICABLE FOR PRESSURES 100 PSI OR LOWER. WHERE PRESSURES ARE IN EXCESS OF 100 PSI, A SEPARATE SUBMISSION IS REQUIRED FOR REVIEW.
7. ALL MATERIALS SHALL BE NSF CERTIFIED AND SHALL MEET THE LEAD (Pb) RESTRICTIONS CONTAINED IN FEDERAL BILL S-3874 (1/2014).
8. FOR CURB BOXES REQUIRED TO BE INSTALLED WITHIN A SIDEWALK OR DRIVEWAY APRON, THE CENTER OF THE CURB BOX SHALL BE SET 1-FOOT FROM THE EDGE OF THE SIDEWALK OR APRON AND CENTERED IN A 2'x2' CONCRETE PANEL AROUND THE CURB BOX. THE 2'x2' PANEL SHALL BE CONSTRUCTED WITH EXPANSION JOINTS. CURB BOX INSTALLATION WITHIN A DRIVEWAY OR APRON MUST BE PREAPPROVED BY SOUTH WHITEHALL TOWNSHIP UTILITIES DEPARTMENT OR SOUTH WHITEHALL TOWNSHIP AUTHORITY ENGINEER.

REVISIONS	SOUTH WHITEHALL TOWNSHIP AUTHORITY STANDARD CONSTRUCTION DETAILS LEHIGH COUNTY, PENNSYLVANIA	
	WATER DISTRIBUTION SYSTEM SERVICE CONNECTION	
	THE PIDCOCK COMPANY <small>CIVIL ENGINEERING AND LAND PLANNING ARCHITECTURE LAND SURVEYING</small>	
	<small>DATE: MARCH 2017</small>	<small>CHKD BY: SRH</small>
	<small>SCALE: NO SCALE</small>	SWT-W-5

Drawing name: S:\Municipalities\Municipal Standard Construction Documents\South Whitehall Township\SWT-W-06.dwg Printed: Mar 22, 2017 4:03pm

NOTES:

1. GATE VALVES SHALL BE IRON BODY, BRONZE MOUNTED VALVES, WITH MECHANICAL JOINT ENDS, NON-RISING STEM. VALVES SHALL OPEN IN A CLOCKWISE DIRECTION AND SHALL BE 200 PSI WORKING PRESSURE RESILIENT-WEDGE GATE VALVES MODEL A-2362 (MAINLINE) OR T-2362 (TAPPING) AS MANUFACTURED BY MUELLER. ALL GATE VALVES SHALL CONFORM TO AWWA SPECIFICATION C509.
2. WHEN APPROVED BY THE ENGINEER, A DEEP VALVE, WHICH WOULD NOT PERMIT THE USE OF THE 6860 SERIES VALVE BOXES, SHALL HAVE A PERMANENT EXTENSION ATTACHED. THE EXTENSION SHALL BE APPROVED BY THE ENGINEER AND ENABLE THE OPERATION OF THE DEEP VALVE BY USING A STANDARD SIX-FOOT VALVE KEY.
3. BOXES SHALL BE SET TO ALLOW EQUAL MOVEMENT ABOVE AND BELOW FINAL GRADE.
4. TAPPING SLEEVES AND VALVES:

TAPPING SLEEVES SHALL BE FABRICATED OF DUCTILE IRON AND SHALL HAVE A MECHANICAL JOINT BODY, A FLANGED OUTLET END AND A 3/4 INCH NPT TEST PLUG. TAPPING SLEEVES SHALL BE MUELLER CO. MODELS H-615 THROUGH H-619, AS APPROPRIATE, BASED UPON THE SIZE AND TYPE OF THE EXISTING MAIN, OR EQUAL. THE SLEEVE SHALL HAVE A 3/8 INCH TAP TO PERMIT PRESSURE TESTING OF THE ASSEMBLY AT 100 PSI (MINIMUM) FOR 15 MINUTES WITHOUT LEAKAGE, BEFORE TAPPING THE MAIN.

TAPPING VALVES SHALL BE RESILIENT-WEDGE GATE VALVES AND SHALL HAVE A FLANGED INLET AND A SPECIALIZED MECHANICAL JOINT OUTLET TO PERMIT CONNECTION TO DRILLING EQUIPMENT.
5. DETAIL APPLICABLE FOR PRESSURES 100 PSI OR LOWER. WHERE PRESSURES ARE IN EXCESS OF 100 PSI, A SEPARATE SUBMISSION IS REQUIRED FOR REVIEW.

CAUTION:

WHEN PIPING SYSTEMS ARE PRESSURE TESTED, IT IS EXTREMELY IMPORTANT AND ESSENTIAL THAT ALL PLUGS INCLUDING TEST PLUGS AND ALL PIPE JOINTS ARE INSTALLED AND RESTRAINED IN SUCH A WAY THAT BLOWOUTS ARE PREVENTED. IT MUST BE REALIZED THAT SUDDEN EXPULSION OF A POORLY INSTALLED PLUG OR SECTION OF PIPE OR OF A TEST PLUG WHICH IS PARTIALLY DEFLATED BEFORE THE PIPE PRESSURE IS RELEASED CAN BE VERY DANGEROUS. FOR THIS REASON IT IS RECOMMENDED THAT EVERY PLUG AND PIPE JOINT BE POSITIVELY BRACED OR OTHERWISE RESTRAINED DURING PRESSURE TESTING AND THAT NO ONE BE ALLOWED IN A MANHOLE ADJOINING A LINE BEING TESTED OR IN THE VICINITY OF AN EXPOSED PLUG OR PIPE SO LONG AS PRESSURE IS MAINTAINED IN THE LINE.

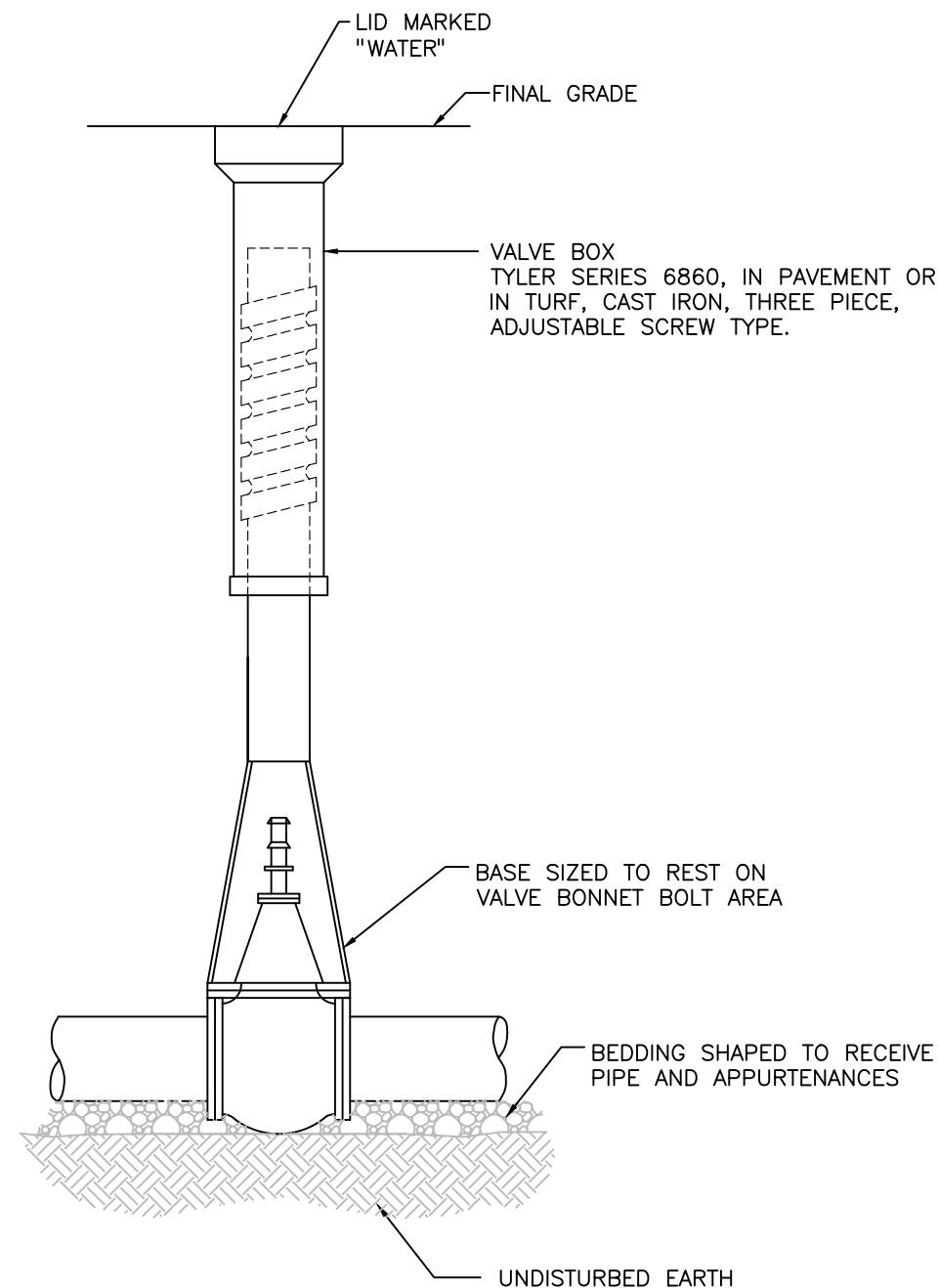

VALVE BOX
NO SCALE

REVISIONS 	SOUTH WHITEHALL TOWNSHIP AUTHORITY STANDARD CONSTRUCTION DETAILS LEHIGH COUNTY, PENNSYLVANIA	
	WATER DISTRIBUTION SYSTEM VALVE AND VALVE BOX	
	THE PIDCOCK COMPANY CIVIL ENGINEERING AND LAND PLANNING ARCHITECTURE LAND SURVEYING <small>OXFORD DRIVE AT FISH HATCHERY ROAD ALLENTOWN, PENNSYLVANIA</small>	
	DATE: MARCH 2017 CHKD BY: SRH SCALE: NO SCALE	SWT-W-6

Drawing name: S:\Municipalities\Municipal Standard Construction Documents\South Whitehall Township\SWT-W-07.dwg Printed: Mar 22, 2017 4:04pm

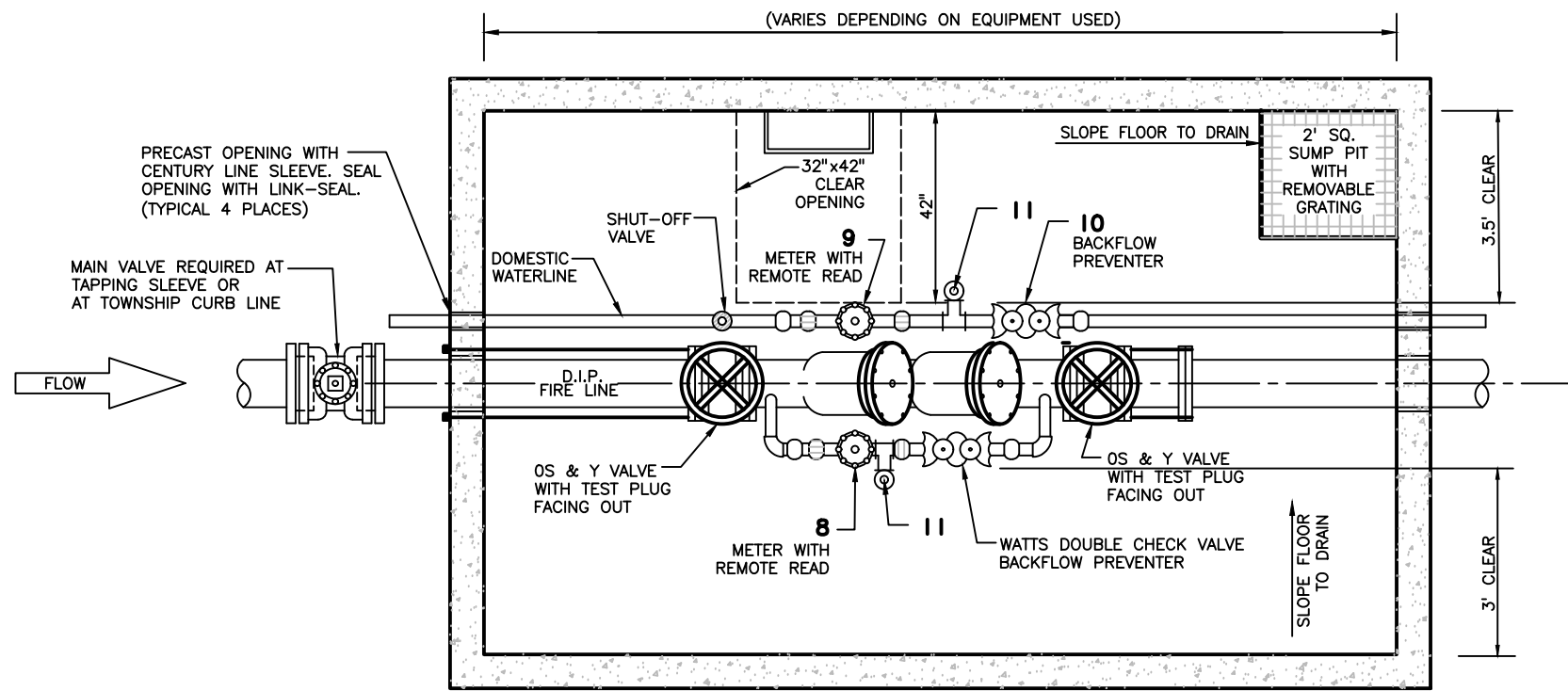

PLAN VIEW

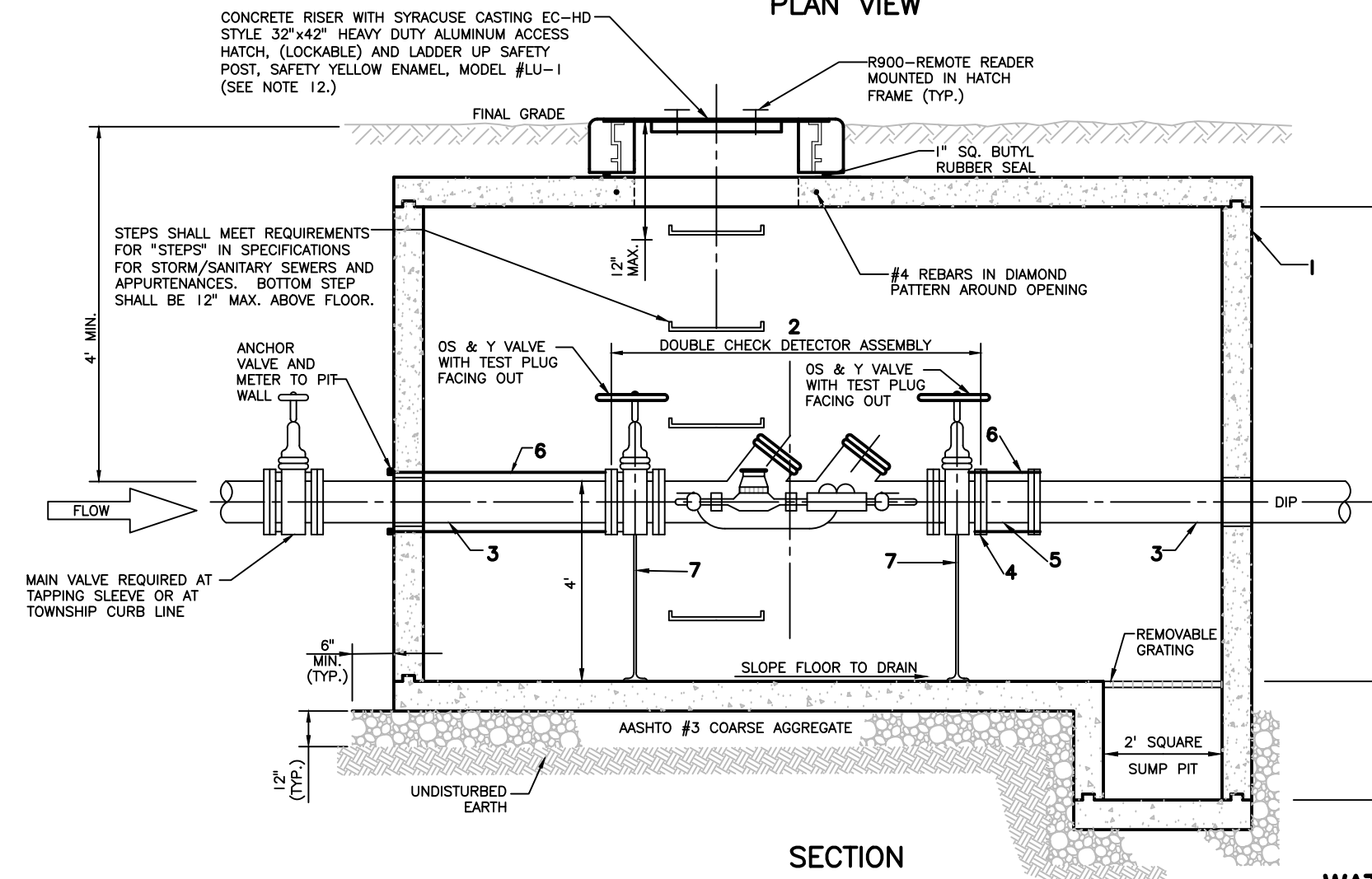

SECTION

GENERAL NOTES:

- PIT AND LID SHALL BE DESIGNED TO WITHSTAND HS-25 LOADING. SUBMIT SHOP DRAWINGS TO ENGINEER PRIOR TO STARTING CONSTRUCTION. MANUFACTURERS OF THE PIT AND LID SHALL HAVE A PROFESSIONAL ENGINEER LICENSED IN THE COMMONWEALTH OF PENNSYLVANIA CERTIFY THAT THE PIT AND LID CAN SUPPORT AN HS-25 LOADING AND THAT THE PIT DESIGN CONFORMS TO ALL APPLICABLE FEDERAL, STATE AND LOCAL STANDARDS, INCLUDING OSHA, LABOR & INDUSTRY, ETC. THE INFORMATION CONTAINED HEREIN IS PROVIDED AS GENERAL GUIDELINES. THE DESIGN ENGINEER SHALL BE RESPONSIBLE FOR FINAL DESIGN CONFORMANCE WITH ALL APPLICABLE REQUIREMENTS, INCLUDING BUT NOT LIMITED TO OSHA, ETC.

CONCRETE:
FC= 4000 PSI @ 28 DAYS, ENTRAINED AIR=6% ± 1-1/2% ACI TYPE 3 CEMENT WITH ASTM C-33 #67 COARSE AGGREGATE.

REINFORCEMENT:
DEFORMED STEEL SHALL CONFORM TO ASTM A615 GRADE 60; WELDED WIRE FABRIC SHALL CONFORM TO ASTM A185.
- FLEXIBLE JOINT MATERIAL SHALL CONFORM TO FEDERAL SPECIFICATIONS SS-S-210.
- PIT EXTERIOR SHALL RECEIVE TWO COATS OF PROPOXY 3009 COAL TAR EPOXY COATING.
- CONCRETE PIERS SUPPORTING PIPING SHALL NOT ENCASE THE PIPING OR FLANGES.
- ALL PIPING SHALL BE SET LEVEL IN A HORIZONTAL PLANE.
- ALL METERS WITHIN THE PIT SHALL BE WATERTIGHT AND HAVE A WATERTIGHT REMOTE. ALL METERS SHALL BE NEPTUNE MODEL #T10, HPT, TRUFLOW COMPOUND, TRUMAG, HP PROTECTUS, HP TURBINE AS REQUIRED. REGISTERS SHALL BE NEPTUNE R900 INTEGRATED ECORDER AND LID-MOUNTED METER INTERFACE UNIT OR R900I. ALL WIRE SHALL BE IN CONDUIT.
- IF STEEL PIPE SUPPORTS ARE USED, THEY SHALL BE BOLTED TO THE PIT FLOOR.
- THE SUMP PIT SHALL BE WATERTIGHT.
- A POST-INDICATOR VALVE IS REQUIRED ON AN EXTERIOR BYPASS LINE, WHICH WILL REQUIRE SEPARATE APPROVAL
- ALL EQUIPMENT AND DEVICES ON THE FIRE LINE SHALL BE LISTED FOR FIRE PROTECTION BY AN ORGANIZATION ACCEPTABLE TO THE AUTHORITY HAVING JURISDICTION.
- METER SIZE BASED ON MAXIMUM FIXTURE LOAD FLOW @ 100% ACCURACY. MINIMUM FLOW OF 1/8-3/4 GPM @ 95% ACCURACY (DEPENDING ON METER CAPABILITY).
- PROVIDE A HEAVY DUTY MANHOLE FRAME AND COVER WITH GASKET SEAL, EAST JORDAN IRON WORKS CATALOG NUMBER 1161, WITH WORDS "PRIVATE WATER" CAST INTO LID, IF POSITIONING THE ACCESS OPENING WITHIN A VEHICULAR DRIVE, ACCESS LANE OR ROADWAY IS UNAVOIDABLE.
- THE TOWNSHIP HAS DETERMINED THE PIT IS A PERMIT-REQUIRED CONFINED SPACE AS DEFINED BY OSHA. DO NOT ENTER UNLESS ENTRY PERMIT IS OBTAINED FROM THE TOWNSHIP AND REQUIRED MEASURES ARE IN PLACE.
- DETAIL APPLICABLE FOR PRESSURES 100 PSI OR LOWER. WHERE PRESSURES ARE IN EXCESS OF 100 PSI, A SEPARATE SUBMISSION IS REQUIRED FOR REVIEW.
- ALL MATERIALS SHALL BE NSF CERTIFIED AND SHALL MEET THE LEAD (Pb) RESTRICTIONS CONTAINED IN FEDERAL BILL S-3874 (1/2014).

CAUTION:
WHEN PIPING SYSTEMS ARE PRESSURE TESTED, IT IS EXTREMELY IMPORTANT AND ESSENTIAL THAT ALL PLUGS INCLUDING TEST PLUGS AND ALL PIPE JOINTS ARE INSTALLED AND RESTRAINED IN SUCH A WAY THAT BLOWOUTS ARE PREVENTED. IT MUST BE REALIZED THAT SUDDEN EXPULSION OF A POORLY INSTALLED PLUG OR SECTION OF PIPE OR OF A TEST PLUG WHICH IS PARTIALLY DEFLATED BEFORE THE PIPE PRESSURE IS RELEASED CAN BE VERY DANGEROUS. FOR THIS REASON IT IS RECOMMENDED THAT EVERY PLUG AND PIPE JOINT BE POSITIVELY BRACED OR OTHERWISE RESTRAINED DURING PRESSURE TESTING AND THAT NO ONE BE ALLOWED IN A MANHOLE ADJOINING A LINE BEING TESTED OR IN THE VICINITY OF AN EXPOSED PLUG OR PIPE SO LONG AS PRESSURE IS MAINTAINED IN THE LINE.

ITEM DESCRIPTION

- REINFORCED CONCRETE PIT AND LID - (SEE NOTES)
- WATTS MODEL - 709-DCDA-OSY-RW-GPM DOUBLE CHECK DETECTOR ASSEMBLY WITH REMOTE READER
- DIP SPOOL PIECE, PE (OUTSIDE END), FLANGE (INSIDE END)
- FLANGED COUPLING ADAPTER FORD (FFCA-XXX STYLE), SMITH BLAIR 912, OR APPROVED EQUAL
- DIP SPOOL PIECE, PLAIN END (TOWARD ASSEMBLY), FLANGE END (TOWARD WALL)
- 3/4" DIA. ALL-THREAD TIE RODS (4)
- 2" DIA. STEEL PIPE STAND OR FORMED CONCRETE SUPPORTS
- BY-PASS METER SHALL BE A NEPTUNE T-10 METER WITH E-CODER R900i PIT VERSION METER INTERFACE IN U.S. GALLONS WITH ANTENNA EXTENDED OUTSIDE OF PIT
- METER SHALL BE A NEPTUNE TRU-FLOW COMPOUND METER WITH E-CODER R900i PIT VERSION METER INTERFACE IN U.S. GALLONS WITH ANTENNA EXTENDED OUTSIDE OF PIT
- WATTS SERIES 007 DCDA (2-3 IN.)
- 1 1/2" OR 2" TEE AND SHUT-OFF VALVE W/STANDARD PIPE THREAD OUTLET (ALSO APPLICABLE FOR INDOOR COMMERCIAL METER ASSEMBLIES)

REVISIONS	SOUTH WHITEHALL TOWNSHIP AUTHORITY STANDARD CONSTRUCTION DETAILS LEHIGH COUNTY, PENNSYLVANIA	
	WATER DISTRIBUTION SYSTEM WATER METER/DOUBLE CHECK DETECTOR ASSEMBLY AND PIT	
	THE PIDCOCK COMPANY CIVIL ENGINEERING AND LAND PLANNING ARCHITECTURE LAND SURVEYING OXFORD DRIVE AT FISH HATCHERY ROAD ALLENTOWN, PENNSYLVANIA	
	DATE: MARCH 2017	CHKD BY: SRH
	SCALE: NO SCALE	
	SWT-W-7	

**WATER METER/DOUBLE CHECK
DETECTOR ASSEMBLY AND PIT**
NO SCALE

Drawing name: S:\Municipalities\Municipal Standard Construction Documents\South Whitehall Township\SWT-W-08.dwg Printed: Mar 22, 2017 4:04pm

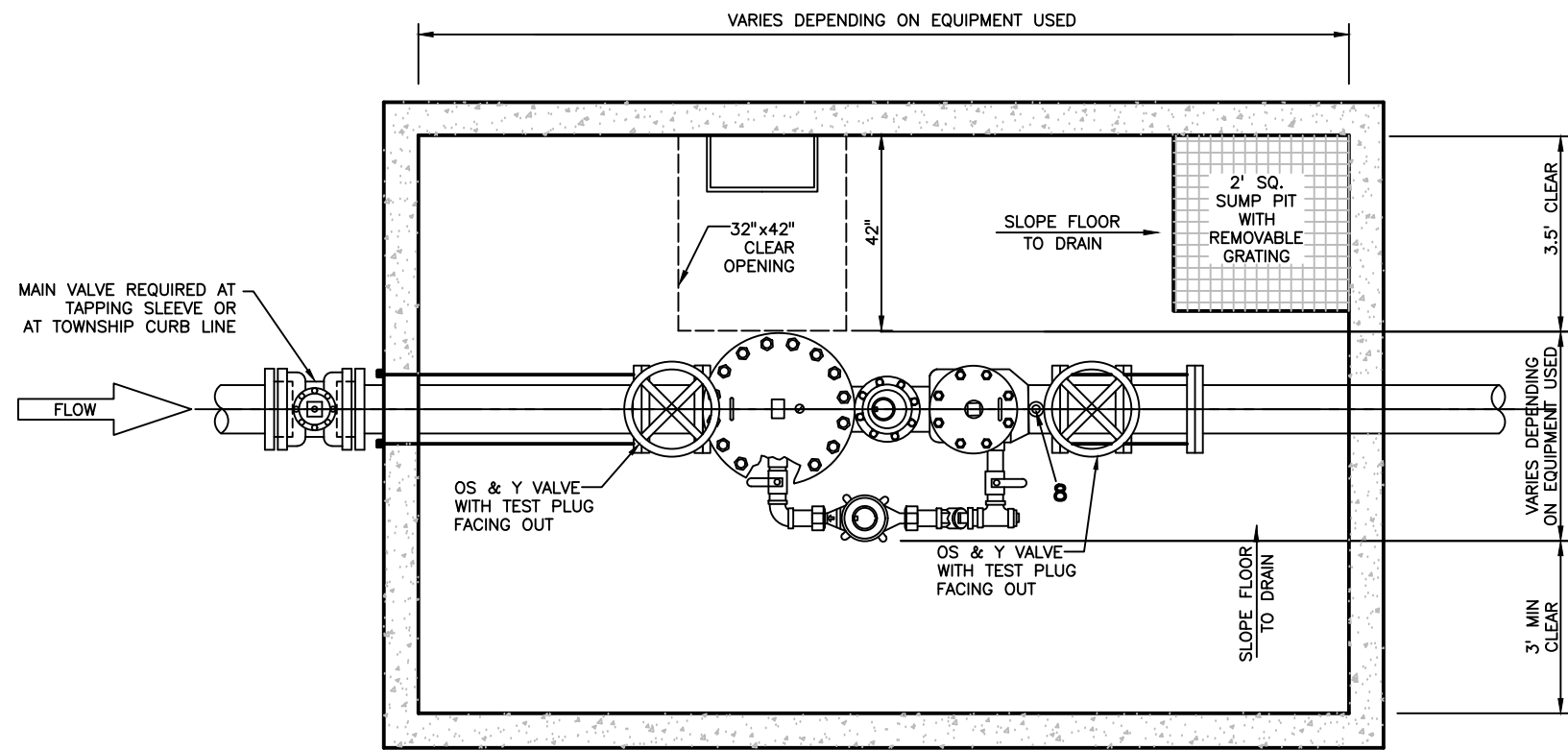

PLAN VIEW

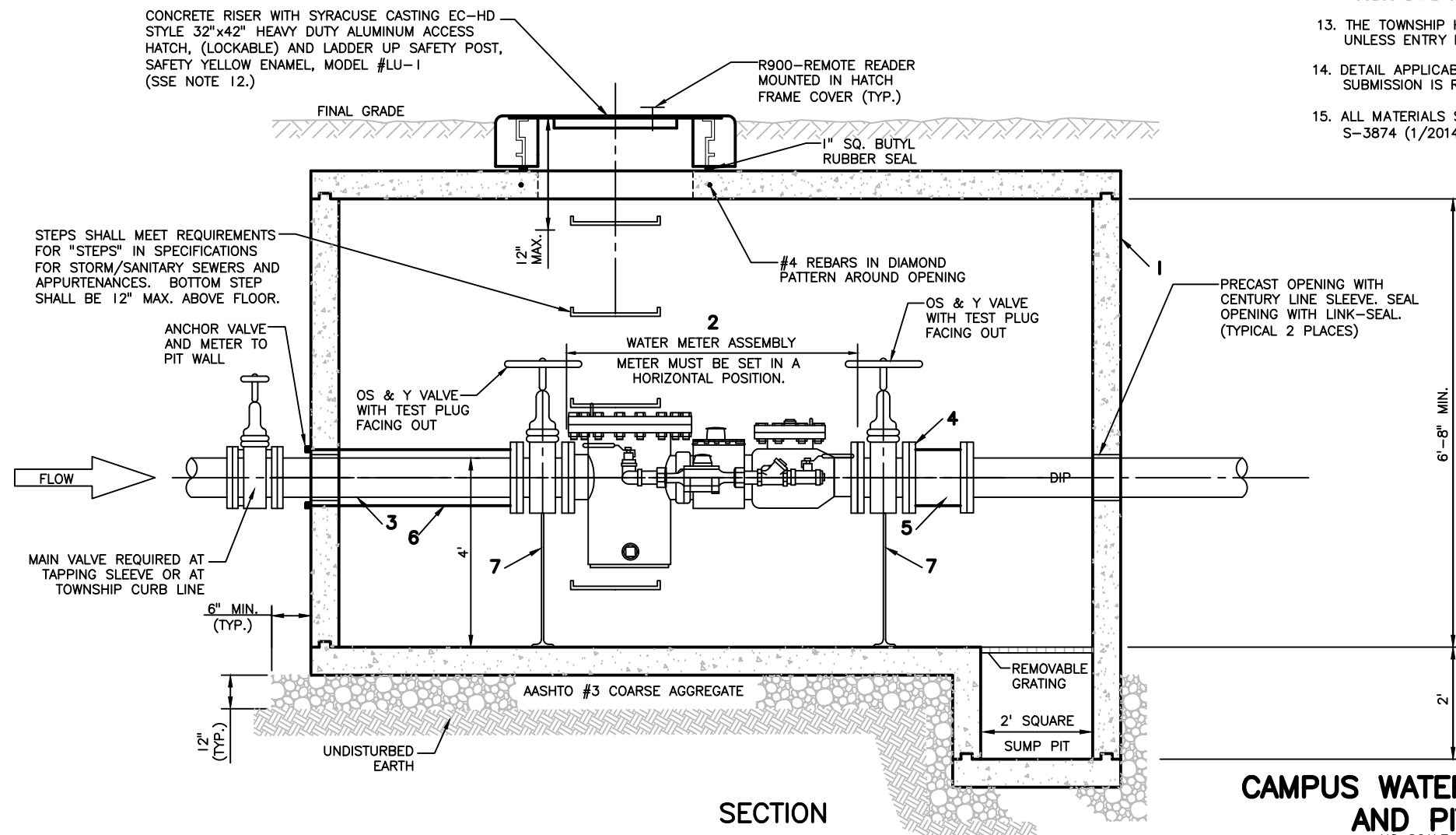

SECTION

CAMPUS WATER METER AND PIT
NO SCALE

GENERAL NOTES:

1. PIT AND LID SHALL BE DESIGNED TO WITHSTAND HS-25 LOADING. SUBMIT SHOP DRAWINGS TO ENGINEER PRIOR TO STARTING CONSTRUCTION. MANUFACTURERS OF THE PIT AND LID SHALL HAVE A PROFESSIONAL ENGINEER LICENSED IN THE COMMONWEALTH OF PENNSYLVANIA CERTIFY THAT THE PIT AND LID CAN SUPPORT AN HS-25 LOADING AND THAT THE PIT DESIGN CONFORMS TO ALL APPLICABLE FEDERAL, STATE AND LOCAL STANDARDS, INCLUDING OSHA, LABOR & INDUSTRY, ETC. THE INFORMATION CONTAINED HEREIN IS PROVIDED AS GENERAL GUIDELINES. THE DESIGN ENGINEER SHALL BE RESPONSIBLE FOR FINAL DESIGN CONFORMANCE WITH ALL APPLICABLE REQUIREMENTS, INCLUDING BUT NOT LIMITED TO OSHA, ETC.
- CONCRETE:
FC= 4000 PSI @ 28 DAYS, ENTRAINED AIR=6% ± 1-1/2% ACI TYPE 3 CEMENT WITH ASTM C-33 #67 COARSE AGGREGATE.
- REINFORCEMENT:
DEFORMED STEEL SHALL CONFORM TO ASTM A615 GRADE 60; WELDED WIRE FABRIC SHALL CONFORM TO ASTM A185.
2. FLEXIBLE JOINT MATERIAL SHALL CONFORM TO FEDERAL SPECIFICATIONS SS-S-210.
3. PIT EXTERIOR SHALL RECEIVE TWO COATS OF PROPOXY 3009 COAL TAR EPOXY COATING.
4. CONCRETE PIERS SUPPORTING PIPING SHALL NOT ENCASE THE PIPING OR FLANGES.
5. ALL PIPING SHALL BE SET LEVEL IN A HORIZONTAL PLANE.
6. ALL METERS WITHIN THE PIT SHALL BE WATERTIGHT AND HAVE A WATERTIGHT REMOTE. ALL METERS SHALL BE NEPTUNE MODEL #T10, HPT, TRUFLOW COMPOUND, TRUMAG, HP PROTECTUS, HP FS TURBINE AS REQUIRED. REGISTERS SHALL BE NEPTUNE R900 INTEGRATED RECORDER AND LID-MOUNTED METER INTERFACE UNIT R900i. ALL WIRE SHALL BE IN CONDUIT.
7. IF STEEL PIPE SUPPORTS ARE USED, THEY SHALL BE BOLTED TO THE PIT FLOOR.
8. THE SUMP PIT SHALL BE WATERTIGHT.
9. A POST-INDICATOR VALVE IS REQUIRED ON AN EXTERIOR BYPASS LINE, WHICH WILL REQUIRE SEPARATE APPROVAL.
10. VALVES MAY BE DIRECTLY BOLTED TO THE METER IF APPROVED BY THE MANUFACTURER.
11. METER SIZE BASED ON MAXIMUM FIXTURE LOAD FLOW @ 100% ACCURACY. MINIMUM FLOW OF 3/8-1 GPM @ 95% ACCURACY (DEPENDING ON METER SIZE AND AS SPECIFIED BY MANUFACTURER).
12. PROVIDE A HEAVY DUTY MANHOLE FRAME AND COVER WITH GASKET SEAL, EAST JORDAN IRON WORKS CATALOG NUMBER 1161, WITH WORDS "PRIVATE WATER" CAST INTO LID, IF POSITIONING THE ACCESS OPENING WITHIN A VEHICULAR DRIVE, ACCESS LANE OR ROADWAY IS UNAVOIDABLE.
13. THE TOWNSHIP HAS DETERMINED THE PIT IS A PERMIT-REQUIRED CONFINED SPACE AS DEFINED BY OSHA. DO NOT ENTER UNLESS ENTRY PERMIT IS OBTAINED FROM THE TOWNSHIP AND REQUIRED MEASURES ARE IN PLACE.
14. DETAIL APPLICABLE FOR PRESSURES 100 PSI OR LOWER. WHERE PRESSURES ARE IN EXCESS OF 100 PSI, A SEPARATE SUBMISSION IS REQUIRED FOR REVIEW.
15. ALL MATERIALS SHALL BE NSF CERTIFIED AND SHALL MEET THE LEAD (Pb) RESTRICTIONS CONTAINED IN FEDERAL BILL S-3874 (1/2014).

CAUTION:

WHEN PIPING SYSTEMS ARE PRESSURE TESTED, IT IS EXTREMELY IMPORTANT AND ESSENTIAL THAT ALL PLUGS INCLUDING TEST PLUGS AND ALL PIPE JOINTS ARE INSTALLED AND RESTRAINED IN SUCH A WAY THAT BLOWOUTS ARE PREVENTED. IT MUST BE REALIZED THAT SUDDEN EXPULSION OF A POORLY INSTALLED PLUG OR SECTION OF PIPE OR OF A TEST PLUG WHICH IS PARTIALLY DEFLATED BEFORE THE PIPE PRESSURE IS RELEASED CAN BE VERY DANGEROUS. FOR THIS REASON IT IS RECOMMENDED THAT EVERY PLUG AND PIPE JOINT BE POSITIVELY BRACED OR OTHERWISE RESTRAINED DURING PRESSURE TESTING AND THAT NO ONE BE ALLOWED IN A MANHOLE ADJOINING A LINE BEING TESTED OR IN THE VICINITY OF AN EXPOSED PLUG OR PIPE SO LONG AS PRESSURE IS MAINTAINED IN THE LINE.

ITEM DESCRIPTION

- 1 REINFORCED CONCRETE PIT AND LID - (SEE NOTES)
- 2 NEPTUNE HIGH PERFORMANCE PROTECTUS III FIRE SERVICE METER, WITH E-CODER R900i PIT VERSION METER INTERFACE MOUNTED IN CASTING COVER WITH ANTENNA EXTENDED OUTSIDE OF PIT
- 3 DIP SPOOL PIECE, PE (OUTSIDE END), FLANGE (INSIDE END)
- 4 FLANGED COUPLING ADAPTER FORD (FFCA-XXX STYLE), SMITH BLAIR 912, OR APPROVED EQUAL
- 5 DIP SPOOL PIECE, PLAIN END (TOWARD ASSEMBLY), FLANGE END (TOWARD WALL)
- 6 3/4" DIA. ALL-THREAD TIE RODS (4)
- 7 2" DIA. STEEL PIPE STAND OR FORMED CONCRETE SUPPORTS
- 8 1 1/2" or 2" NIPPLE AND SHUT-OFF VALVE W/STANDARD PIPE THREAD OUTLET

REVISIONS	SOUTH WHITEHALL TOWNSHIP AUTHORITY STANDARD CONSTRUCTION DETAILS LEHIGH COUNTY, PENNSYLVANIA
	WATER DISTRIBUTION SYSTEM CAMPUS WATER METER AND PIT
	THE PIDCOCK COMPANY CIVIL ENGINEERING AND LAND PLANNING ARCHITECTURE LAND SURVEYING
	DATE: MARCH 2017 CHKD BY: SRH SCALE: NO SCALE
	OXFORD DRIVE AT FISH HATCHERY ROAD ALLENTOWN, PENNSYLVANIA SWT-W-8

Drawing name: S:\Municipalities\Municipal Standard Construction Documents\South Whitehall Township\SWT-WORKING DOCUMENTS\SWT-W-09.dwg Printed: Mar 22, 2017 4:04pm

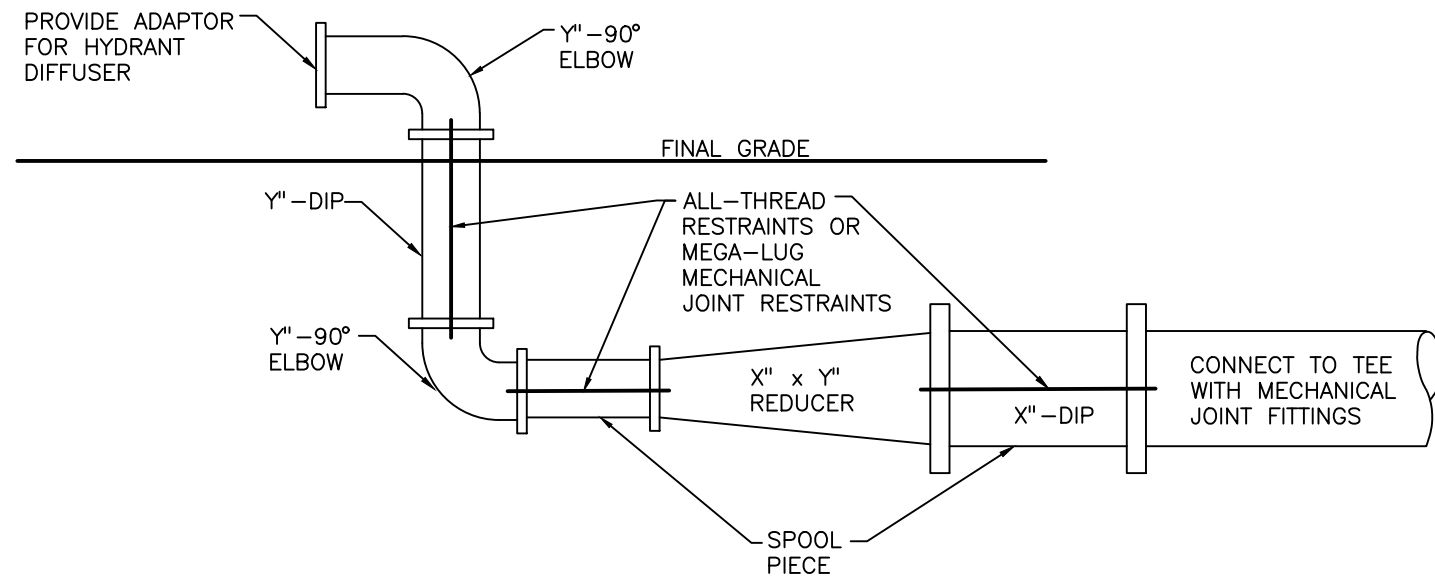

NOTES:

1. THIS PROCEDURE IS PER AWWA REQUIREMENTS.
2. X" = DIAMETER OF MAIN.
3. Y" = 1/2 DIAMETER OF MAIN.
4. BACKFILL AND TAMP PRIOR TO FLUSHING.
5. APPARATUS TO BE REMOVED FROM TEE AFTER FLUSHING AND TEE SHALL BE PLUGGED.

CAUTION:

WHEN PIPING SYSTEMS ARE PRESSURE TESTED, IT IS EXTREMELY IMPORTANT AND ESSENTIAL THAT ALL PLUGS INCLUDING TEST PLUGS AND ALL PIPE JOINTS ARE INSTALLED AND RESTRAINED IN SUCH A WAY THAT BLOWOUTS ARE PREVENTED. IT MUST BE REALIZED THAT SUDDEN EXPULSION OF A POORLY INSTALLED PLUG OR SECTION OF PIPE OR OF A TEST PLUG WHICH IS PARTIALLY DEFLATED BEFORE THE PIPE PRESSURE IS RELEASED CAN BE VERY DANGEROUS. FOR THIS REASON IT IS RECOMMENDED THAT EVERY PLUG AND PIPE JOINT BE POSITIVELY BRACED OR OTHERWISE RESTRAINED DURING PRESSURE TESTING AND THAT NO ONE BE ALLOWED IN A MANHOLE ADJOINING A LINE BEING TESTED OR IN THE VICINITY OF AN EXPOSED PLUG OR PIPE SO LONG AS PRESSURE IS MAINTAINED IN THE LINE.

HIGH-VOLUME FLUSHING APPARATUS
NO SCALE

REVISIONS	SOUTH WHITEHALL TOWNSHIP AUTHORITY STANDARD CONSTRUCTION DETAILS LEHIGH COUNTY, PENNSYLVANIA
	WATER DISTRIBUTION SYSTEM HIGH-VOLUME FLUSHING APPARATUS
	THE PIDCOCK COMPANY <small>CIVIL ENGINEERING AND LAND PLANNING ARCHITECTURE LAND SURVEYING</small> OXFORD DRIVE AT FISH HATCHERY ROAD ALLENTOWN, PENNSYLVANIA
	<small>DATE: MARCH 2017</small> <small>CHKD BY: SRH</small> <small>SCALE: NO SCALE</small> SWT-W-9

Drawing name: S:\Municipalities\Municipal Standard Construction Documents\South Whitehall Township\SWT-W-10.dwg Printed: Mar 22, 2017 4:04pm

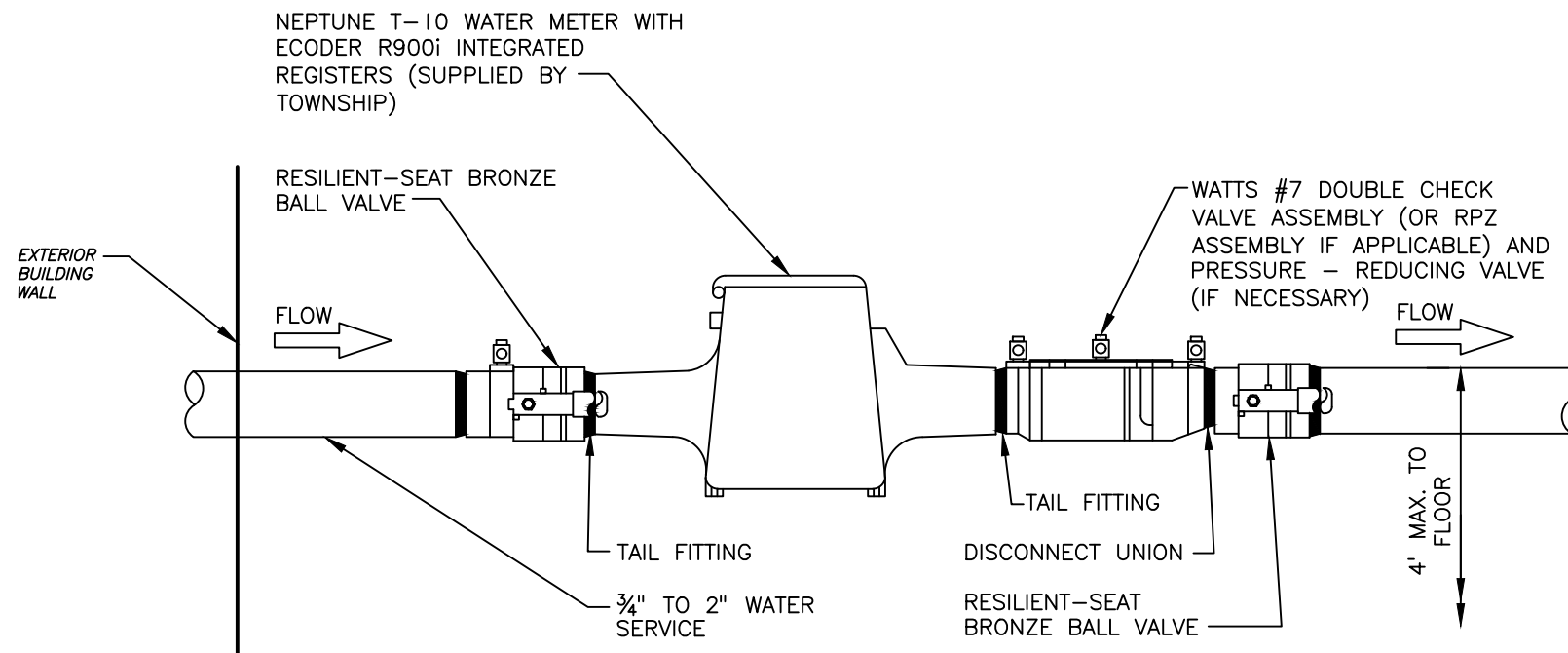

3/4" - 2" WATER METER ASSEMBLY
NO SCALE

CAUTION:

WHEN PIPING SYSTEMS ARE PRESSURE TESTED, IT IS EXTREMELY IMPORTANT AND ESSENTIAL THAT ALL PLUGS INCLUDING TEST PLUGS AND ALL PIPE JOINTS ARE INSTALLED AND RESTRAINED IN SUCH A WAY THAT BLOWOUTS ARE PREVENTED. IT MUST BE REALIZED THAT SUDDEN EXPULSION OF A POORLY INSTALLED PLUG OR SECTION OF PIPE OR OF A TEST PLUG WHICH IS PARTIALLY DEFLATED BEFORE THE PIPE PRESSURE IS RELEASED CAN BE VERY DANGEROUS. FOR THIS REASON IT IS RECOMMENDED THAT EVERY PLUG AND PIPE JOINT BE POSITIVELY BRACED OR OTHERWISE RESTRAINED DURING PRESSURE TESTING AND THAT NO ONE BE ALLOWED IN A MANHOLE ADJOINING A LINE BEING TESTED OR IN THE VICINITY OF AN EXPOSED PLUG OR PIPE SO LONG AS PRESSURE IS MAINTAINED IN THE LINE.

NOTES:

1. ALL MATERIALS SHALL BE NSF CERTIFIED AND SHALL MEET THE LEAD (Pb) RESTRICTIONS CONTAINED IN FEDERAL BILL S-3874 (1/2014).
2. INSTALLATION SHALL CONFORM TO THE INTERNATIONAL PLUMBING CODE (LATEST EDITION).
3. CARE SHALL BE TAKEN DURING INSTALLATION TO PREVENT DEBRIS FROM ENTERING THE PIPING. BEFORE THE METER IS PLACED IN SERVICE, THE PIPING ADJACENT TO THE METER SHALL BE FLUSHED.
4. FOR METALLIC SERVICE PIPES, AN ELECTRICAL GROUNDING STRAP SHALL BE CONNECTED TO PIPES ON BOTH SIDES OF THE METER ASSEMBLY.
5. THE PIPES ON BOTH SIDES OF THE METER SHALL BE ALIGNED SUCH THAT THE COUPLING AND METER THREADS WILL ENGAGE WITHOUT BINDING OR CROSS-THREADING.
6. BEFORE INSTALLING THE METER, THE THREAD PROTECTORS AND SPUD CAPS SHALL BE REMOVED, TAKING PRECAUTION AGAINST DEBRIS ENTERING THE METER.
7. THE METER SHALL BE THE FIRST ITEM AFTER THE BALL VALVE. THE METER SHALL BE READILY ACCESSIBLE AT ALL TIMES.
8. WHEN THE METER ASSEMBLY IS COMPLETE, ALL COMPONENTS ARE TIGHTENED AND VALVES CLOSED, THE INLET VALVE SHALL BE OPENED SLOWLY TO FILL THE METER. NEXT, THE OUTLET VALVE SHALL BE OPENED SLOWLY, AND AIR SHALL BE DISSIPATED WHILE FLUSHING THE PIPING THROUGH A DOWNSTREAM FAUCET. THE METER SHALL THEN BE INSPECTED FOR PROPER OPERATION.
9. THE FAUCET SHALL BE CLOSED AND THE METER ASSEMBLY SHALL BE CHECKED AT LINE PRESSURE FOR LEAKS.
10. THE R900i ENCODER SHALL BE INSTALLED BY PLACING IT ON THE METER AT THE POSITION RECOMMENDED BY THE MANUFACTURER AND TURNING CLOCKWISE UNTIL LOCKED INTO PLACE. THE SEAL PIN SHALL BE INSERTED TO SECURE THE REGISTER.
11. THE R900i PIT EXTENSION SHALL BE INSTALLED IN ACCORDANCE WITH THE MANUFACTURER'S INSTRUCTIONS THAT ACCOMPANY THE EQUIPMENT. THE READOUT SHALL BE MOUNTED ON THE STREET SIDE OF THE BUILDING AND CLEAR OF ANY OBSTRUCTIONS.
12. THE METER SHALL BE INSTALLED WITH THE FLOW ARROW FACING OUTLET PIPING.
13. ECODER R900i INTEGRATED REGISTERS PIT APPLICATIONS SHALL INCLUDE A 6 OR 20 FOOT LONG ANTENNA EXTENSION.
14. METER SIZE 3/4" TO 1" ARE SUPPLIED BY THE TOWNSHIP AUTHORITY; METERS OVER 1" ARE TO BE SUPPLIED BY THE DEVELOPER.

REVISIONS	SOUTH WHITEHALL TOWNSHIP AUTHORITY STANDARD CONSTRUCTION DETAILS LEHIGH COUNTY, PENNSYLVANIA	
	WATER DISTRIBUTION SYSTEM 3/4" - 2" WATER METER ASSEMBLY	
	THE PIDCOCK COMPANY <small>CIVIL ENGINEERING AND LAND PLANNING ARCHITECTURE LAND SURVEYING</small>	DATE: MARCH 2017 CHKD BY: SRH SCALE: NO SCALE
	<small>OXFORD DRIVE AT FISH HATCHERY ROAD ALLENTOWN, PENNSYLVANIA</small>	SWT-W-10

Drawing name: S:\Municipalities\Municipal Standard Construction Documents\South Whitehall Township\SWT-W-11.dwg Printed: Mar 22, 2017 - 4:04pm

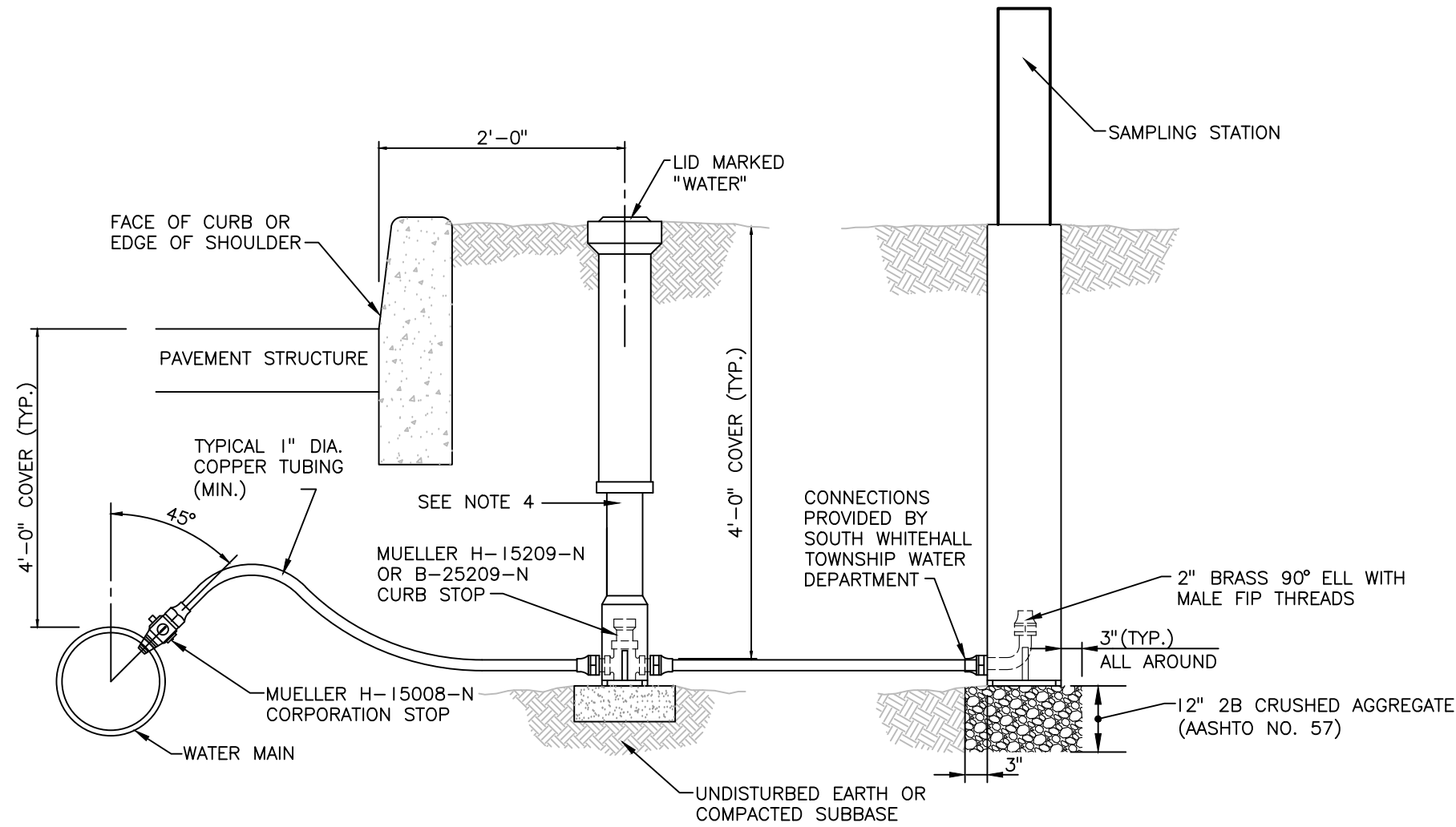

SAMPLING STATION
NO SCALE

NOTES:

1. SAMPLING STATION SHALL BE MAINGUARD #66, BLUE-POWDER COATED, AS MANUFACTURED BY KUPFERLE FOUNDRY, ST. LOUIS MO.
2. IF DIRECTED BY THE TOWNSHIP PUBLIC WORKS DEPARTMENT, THE SAMPLE STATION SHALL BE ECLIPSE #9900.
3. CONTRACTOR TO INSTALL THE SAMPLING STATION WHERE INDICATED ON THE PLANS OR REQUIRED BY THE TOWNSHIP.
4. CORPORATION STOPS SHALL BE MUELLER B-25208-N, 1" DIA. WITH MALE IRON PIPE INLET CONNECTION AND COMPRESSION CONNECTION FOR THE OUTLET.
5. CURB STOPS SHALL BE MUELLER H-15209-N OR B-25209-N, 1" DIA. WITH COMPRESSION CONNECTIONS.
6. VALVE BOXES SHALL BE CAST IRON ADJUSTABLE SCREW TYPE BIBBY AND LAPERLE TWO-PIECE, ARCH BASE WITH 4/4" INSIDE DIA., LOCKABLE LID.
7. AN 8" CLAY ENVELOPE SHALL BE PLACED AROUND ALL COPPER LINES.
8. DETAIL APPLICABLE FOR PRESSURES 100 PSI OR LOWER. WHERE PRESSURES ARE IN EXCESS OF 100 PSI, A SEPARATE SUBMISSION IS REQUIRED FOR REVIEW.
9. ALL MATERIALS SHALL BE NSF CERTIFIED AND SHALL MEET THE LEAD (Pb) RESTRICTIONS CONTAINED IN FEDERAL BILL S-3874 (1/2014).

CAUTION:

WHEN PIPING SYSTEMS ARE PRESSURE TESTED, IT IS EXTREMELY IMPORTANT AND ESSENTIAL THAT ALL PLUGS INCLUDING TEST PLUGS AND ALL PIPE JOINTS ARE INSTALLED AND RESTRAINED IN SUCH A WAY THAT BLOWOUTS ARE PREVENTED. IT MUST BE REALIZED THAT SUDDEN EXPULSION OF A POORLY INSTALLED PLUG OR SECTION OF PIPE OR OF A TEST PLUG WHICH IS PARTIALLY DEFLATED BEFORE THE PIPE PRESSURE IS RELEASED CAN BE VERY DANGEROUS. FOR THIS REASON IT IS RECOMMENDED THAT EVERY PLUG AND PIPE JOINT BE POSITIVELY BRACED OR OTHERWISE RESTRAINED DURING PRESSURE TESTING AND THAT NO ONE BE ALLOWED IN A MANHOLE ADJOINING A LINE BEING TESTED OR IN THE VICINITY OF AN EXPOSED PLUG OR PIPE SO LONG AS PRESSURE IS MAINTAINED IN THE LINE.

REVISIONS	SOUTH WHITEHALL TOWNSHIP AUTHORITY STANDARD CONSTRUCTION DETAILS LEHIGH COUNTY, PENNSYLVANIA	
	WATER DISTRIBUTION SYSTEM SAMPLING STATION	
	THE PIDCOCK COMPANY <small>CIVIL ENGINEERING AND LAND PLANNING ARCHITECTURE LAND SURVEYING</small> <small>OXFORD DRIVE AT FISH HATCHERY ROAD ALLENTOWN, PENNSYLVANIA</small>	
	<small>DATE: MARCH 2017</small>	<small>CHKD BY: SRH</small>
	<small>SCALE: NO SCALE</small>	<small>SWT-W-11</small>

Drawing name: S:\Municipalities\MUNICIPAL STANDARD CONSTRUCTION DOCUMENTS\CONSTRUCTION DOCUMENTS\SWT-W-12.dwg Printed: Mar 22, 2017 4:04pm

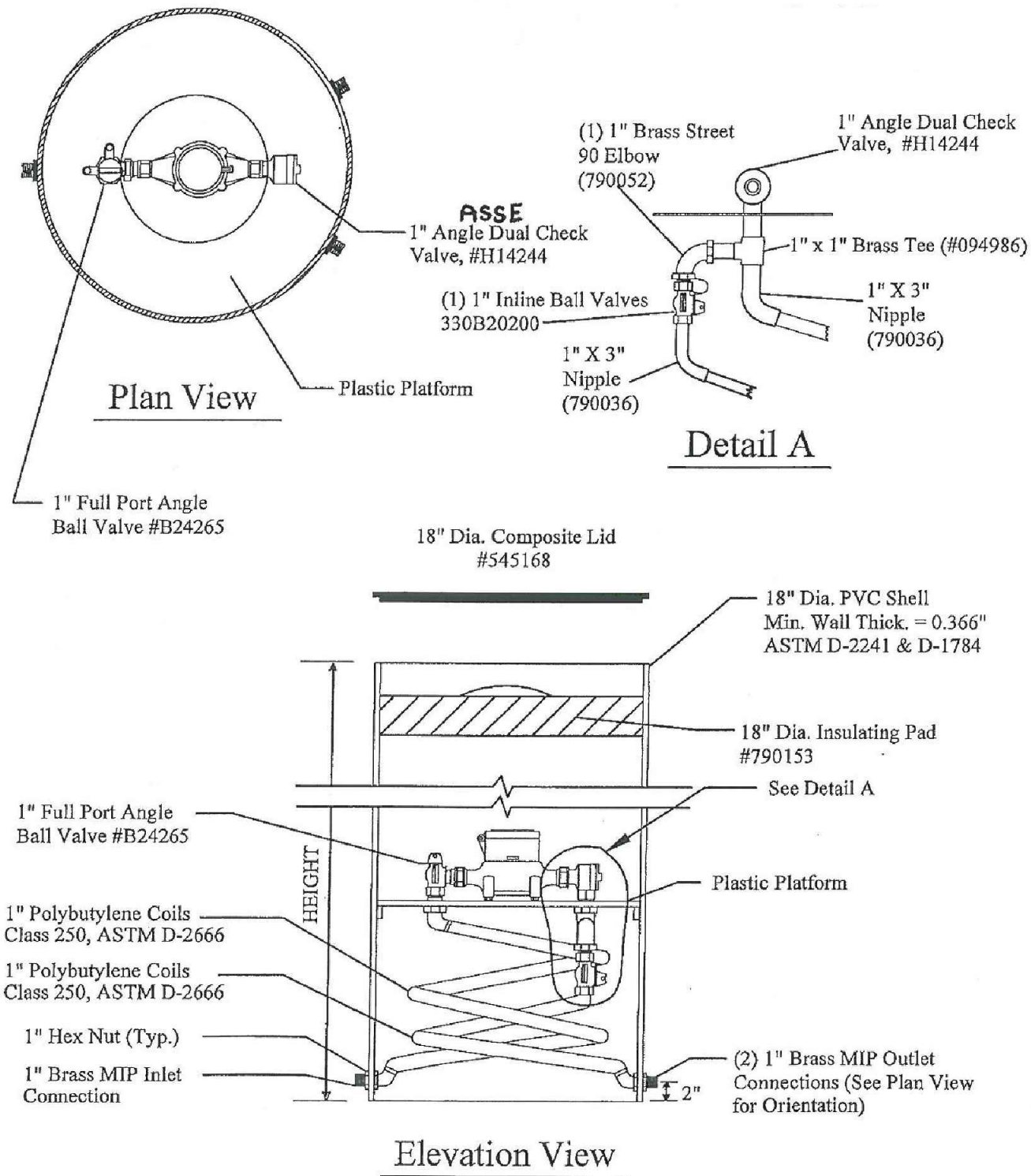

WATER METER PIT FOR 1-INCH METER
NO SCALE

NOTES:

- METER NOT INCLUDED.
- METER PITS FOR RESIDENTIAL FIRE-PROTECTION SERVICES SHALL BE MUELLER/HUNT 18-INCH DIAMETER COIL SINGLE METER PIT FOR 1-INCH METER (NOT INCLUDED) 330CS1848 FSBS000342 WITH 18-INCH DIAMETER LID (#545168) AND 18-INCH DIAMETER, 4-INCH THICK INSULATING PAD (790153).

CAUTION:

WHEN PIPING SYSTEMS ARE PRESSURE TESTED, IT IS EXTREMELY IMPORTANT AND ESSENTIAL THAT ALL PLUGS INCLUDING TEST PLUGS AND ALL PIPE JOINTS ARE INSTALLED AND RESTRAINED IN SUCH A WAY THAT BLOWOUTS ARE PREVENTED. IT MUST BE REALIZED THAT SUDDEN EXPULSION OF A POORLY INSTALLED PLUG OR SECTION OF PIPE OR OF A TEST PLUG WHICH IS PARTIALLY DEFLATED BEFORE THE PIPE PRESSURE IS RELEASED CAN BE VERY DANGEROUS. FOR THIS REASON IT IS RECOMMENDED THAT EVERY PLUG AND PIPE JOINT BE POSITIVELY BRACED OR OTHERWISE RESTRAINED DURING PRESSURE TESTING AND THAT NO ONE BE ALLOWED IN A MANHOLE ADJOINING A LINE BEING TESTED OR IN THE VICINITY OF AN EXPOSED PLUG OR PIPE SO LONG AS PRESSURE IS MAINTAINED IN THE LINE.

REVISIONS	SOUTH WHITEHALL TOWNSHIP AUTHORITY STANDARD CONSTRUCTION DETAILS LEHIGH COUNTY, PENNSYLVANIA	
	WATER DISTRIBUTION SYSTEM WATER METER PIT FOR 1-INCH METER	
	THE PIDCOCK COMPANY CIVIL ENGINEERING AND LAND PLANNING ARCHITECTURE LAND SURVEYING OXFORD DRIVE AT FISH HATCHERY ROAD ALLENTOWN, PENNSYLVANIA	DATE: MARCH 2017 CHKD BY: SRH SCALE: NO SCALE SWT-W-12